

**SIEMENS**

Operating Instructions

**SINAMICS**

**V90**

Pulse train, USS/Modbus interface

Edition

12/2018

[www.siemens.com/drives](http://www.siemens.com/drives)



# SIEMENS

## SINAMICS/SIMOTICS

### SINAMICS V90, SIMOTICS S-1FL6

#### Operating Instructions

Preface	
Fundamental safety instructions	1
General information	2
Mounting	3
Connecting	4
Commissioning	5
Basic operator panel (BOP)	6
Control functions	7
Safety Integrated function	8
Tuning	9
Parameters	10
Diagnostics	11
Appendix	A

Pulse train, USS/Modbus interface

## Legal information

### Warning notice system

This manual contains notices you have to observe in order to ensure your personal safety, as well as to prevent damage to property. The notices referring to your personal safety are highlighted in the manual by a safety alert symbol, notices referring only to property damage have no safety alert symbol. These notices shown below are graded according to the degree of danger.

<b>⚠ DANGER</b>
indicates that death or severe personal injury <b>will</b> result if proper precautions are not taken.
<b>⚠ WARNING</b>
indicates that death or severe personal injury <b>may</b> result if proper precautions are not taken.
<b>⚠ CAUTION</b>
indicates that minor personal injury can result if proper precautions are not taken.
<b>NOTICE</b>
indicates that property damage can result if proper precautions are not taken.

If more than one degree of danger is present, the warning notice representing the highest degree of danger will be used. A notice warning of injury to persons with a safety alert symbol may also include a warning relating to property damage.

### Qualified Personnel

The product/system described in this documentation may be operated only by **personnel qualified** for the specific task in accordance with the relevant documentation, in particular its warning notices and safety instructions. Qualified personnel are those who, based on their training and experience, are capable of identifying risks and avoiding potential hazards when working with these products/systems.

### Proper use of Siemens products

Note the following:

<b>⚠ WARNING</b>
Siemens products may only be used for the applications described in the catalog and in the relevant technical documentation. If products and components from other manufacturers are used, these must be recommended or approved by Siemens. Proper transport, storage, installation, assembly, commissioning, operation and maintenance are required to ensure that the products operate safely and without any problems. The permissible ambient conditions must be complied with. The information in the relevant documentation must be observed.

### Trademarks

All names identified by ® are registered trademarks of Siemens AG. The remaining trademarks in this publication may be trademarks whose use by third parties for their own purposes could violate the rights of the owner.

### Disclaimer of Liability

We have reviewed the contents of this publication to ensure consistency with the hardware and software described. Since variance cannot be precluded entirely, we cannot guarantee full consistency. However, the information in this publication is reviewed regularly and any necessary corrections are included in subsequent editions.



# Preface

## Documentation components

Document	Content
Operating Instructions	(this manual)
Getting Started	Describes how to install, connect, operate, and perform basic commissioning of the SINAMICS V90 servo system.
SIMOTICS S-1FL6 Servo Motors Installation Guide	Describes how to install the SMOTICS S-1FL6 servo motor and relevant safety notices.
SINAMICS V90 Servo Drives Information Guide	Introduces the basic information of the documents and describes how to find all the SINAMICS V90 documents from the website.
SINAMICS V90 V-ASSISTANT Online Help	Describes how to perform fast commissioning and diagnostics for the SINAMICS V90 drives via the SINAMICS V-ASSISTANT engineering tool.

## Target group

This manual provides information about the SINAMICS V90 servo system for planners, operators, mechanical engineers, electrical engineers, commissioning engineers, and service engineers.

## Technical support

Country	Hotline
China	+86 400 810 4288
Germany	+49 911 895 7222
Italy	+39 (02) 24362000
India	+91 22 2760 0150
Turkey	+90 (216) 4440747
Further service contact information: Support contacts ( <a href="https://support.industry.siemens.com/cs/ww/en/">https://support.industry.siemens.com/cs/ww/en/</a> )	

## Product maintenance

The components are subject to continuous further development within the scope of product maintenance (improvements to robustness, discontinuations of components, etc).

These further developments are "spare parts-compatible" and do not change the article number.

In the scope of such spare parts-compatible further developments, connector positions are sometimes changed slightly. This does not cause any problems with proper use of the

components. Please take this fact into consideration in special installation situations (e.g. allow sufficient clearance for the cable length).

### Use of third-party products

This document contains recommendations relating to third-party products. Siemens accepts the fundamental suitability of these third-party products.

You can use equivalent products from other manufacturers.

Siemens does not accept any warranty for the properties of third-party products.

### Compliance with the General Data Protection Regulation

Siemens respects the principles of data protection, in particular the data minimization rules (privacy by design).

For this product, this means:

The product does not process neither store any person-related data, only technical function data (e.g. time stamps). If the user links these data with other data (e.g. shift plans) or if he stores person-related data on the same data medium (e.g. hard disk), thus personalizing these data, he has to ensure compliance with the applicable data protection stipulations.

### Recycling and disposal



For environmentally-friendly recycling and disposal of your old device, please contact a company certified for the disposal of waste electrical and electronic equipment, and dispose of the old device as prescribed in the respective country of use.

# Table of contents

	<b>Preface .....</b>	<b>3</b>
<b>1</b>	<b>Fundamental safety instructions .....</b>	<b>11</b>
1.1	General safety instructions .....	11
1.2	Equipment damage due to electric fields or electrostatic discharge .....	18
1.3	Warranty and liability for application examples .....	18
1.4	Industrial security .....	19
1.5	Residual risks of power drive systems.....	20
<b>2</b>	<b>General information .....</b>	<b>21</b>
2.1	Scope of delivery .....	21
2.1.1	Drive components .....	21
2.1.2	Motor components .....	26
2.2	Device combination.....	30
2.3	Product overview .....	33
2.4	System configuration .....	37
2.5	Accessories.....	40
2.5.1	MOTION-CONNECT 300 cables and connectors .....	40
2.5.2	Setpoint cables and connectors.....	42
2.5.3	Connectors used on the drive front panel.....	42
2.5.4	External 24 VDC power supply .....	43
2.5.5	Fuse/Type-E combination motor controller.....	44
2.5.6	Braking resistor .....	45
2.5.7	Line filter .....	46
2.5.8	Micro SD card/SD card .....	52
2.5.9	Replacement fans .....	52
2.6	Function list.....	52
2.7	Technical data.....	54
2.7.1	Technical data - servo drives .....	54
2.7.1.1	SINAMICS V90 200 V variant .....	54
2.7.1.2	SINAMICS V90 400 V variant .....	57
2.7.2	Technical data - servo motors .....	61
2.7.2.1	1FL6 servo motor - low inertia .....	61
2.7.2.2	1FL6 servo motor - high inertia .....	65
2.7.2.3	Power derating .....	69
2.7.3	Technical data - cables .....	69
2.7.4	Address of CE-authorized manufacturer .....	71
<b>3</b>	<b>Mounting.....</b>	<b>72</b>
3.1	Mounting the drive .....	72
3.1.1	Mounting orientation and clearance.....	73

3.1.2	Drill patterns and outline dimensions .....	75
3.1.3	Mounting the drive .....	79
3.2	Mounting the motor .....	80
3.2.1	Mounting orientation and dimensions .....	81
3.2.2	Mounting the motor .....	90
3.2.3	Motor heating conditions .....	91
<b>4</b>	<b>Connecting .....</b>	<b>92</b>
4.1	System connection.....	92
4.2	Main circuit wiring.....	99
4.2.1	Line supply - L1, L2, L3.....	99
4.2.2	Motor power - U, V, W .....	101
4.3	Control/status interface - X8 .....	103
4.3.1	Digital inputs/outputs (DIs/DOs).....	106
4.3.1.1	DIs .....	107
4.3.1.2	DOs .....	112
4.3.2	Pulse train inputs/encoder outputs (PTIs/PTOs) .....	115
4.3.2.1	PTIs .....	115
4.3.2.2	PTOs .....	116
4.3.3	Analog inputs/outputs (AIs/AOs).....	117
4.3.3.1	AIs .....	117
4.3.3.2	AOs .....	117
4.3.4	Standard application wiring (factory setting).....	119
4.3.4.1	Pulse train input position control (PTI).....	119
4.3.4.2	Internal position control (IPos) .....	121
4.3.4.3	Speed control (S) .....	123
4.3.4.4	Torque control (T) .....	125
4.3.5	Connection examples with PLCs .....	126
4.3.5.1	SIMATIC S7-200 SMART .....	126
4.3.5.2	SIMATIC S7-200 .....	131
4.3.5.3	SIMATIC S7-1200 .....	135
4.4	24 V power supply/STO .....	139
4.5	Encoder interface - X9 .....	140
4.6	External braking resistor - DCP, R1.....	144
4.7	Motor holding brake .....	145
4.8	RS485 interface - X12.....	150
<b>5</b>	<b>Commissioning .....</b>	<b>151</b>
5.1	General commissioning information.....	151
5.2	Initial commissioning in JOG mode.....	153
5.3	Commissioning in pulse train position control mode (PTI) .....	155
5.4	Commissioning in internal position control mode (IPos).....	156
5.5	Commissioning in speed control mode (S) .....	158
5.6	Commissioning in torque control mode (T).....	160

<b>6</b>	<b>Basic operator panel (BOP)</b> .....	<b>162</b>
6.1	BOP overview .....	162
6.1.1	LED status indicators .....	163
6.1.2	BOP display .....	163
6.1.3	Control buttons.....	166
6.2	Parameter structure .....	167
6.3	Actual status display .....	168
6.4	Basic operations .....	169
6.4.1	Editing parameters.....	170
6.4.2	Viewing parameters .....	172
6.4.3	Searching parameters in "P ALL" menu .....	172
6.5	Auxiliary functions .....	173
6.5.1	JOG.....	174
6.5.2	Saving parameters (RAM to ROM).....	175
6.5.3	Setting parameters to default.....	176
6.5.4	Transferring data (drive to SD) .....	176
6.5.5	Transferring data (SD to drive) .....	177
6.5.6	Updating firmware.....	178
6.5.7	Adjusting AI offsets .....	179
6.5.8	Adjusting an absolute encoder .....	180
<b>7</b>	<b>Control functions</b> .....	<b>181</b>
7.1	Compound controls.....	181
7.2	General functions.....	183
7.2.1	Travel to fixed stop.....	183
7.2.2	Servo ON .....	187
7.2.3	Motor direction of rotation .....	188
7.2.4	Over-travel .....	189
7.2.5	Stopping method at servo OFF.....	191
7.3	Pulse train input position control (PTI).....	192
7.3.1	Sequence of SON.....	192
7.3.2	Selecting a setpoint pulse train input channel .....	192
7.3.3	Selecting a setpoint pulse train input form.....	193
7.3.4	In position (INP) .....	194
7.3.5	Smoothing function .....	194
7.3.6	Electronic gear ratio .....	195
7.3.7	Inhibiting pulse train input setpoint (P-TRG).....	198
7.3.8	Speed limit .....	199
7.3.9	Torque limit .....	200
7.3.10	Clearing droop pulses (CLR) .....	203
7.3.11	Referencing (only for absolute encoder).....	204
7.3.12	PTO function .....	204
7.4	Internal position control (IPos) .....	206
7.4.1	Setting mechanical system .....	206
7.4.2	Setting fixed position setpoint .....	207
7.4.3	Selecting a positioning mode - absolute/incremental .....	209
7.4.4	Configuring the linear/modular axis .....	210
7.4.5	Backlash compensation .....	210

7.4.6	Referencing.....	211
7.4.7	Software position limit.....	220
7.4.8	Speed limit.....	220
7.4.9	Torque limit.....	220
7.4.10	Selecting a fixed position setpoint and starting positioning.....	220
7.4.11	Position tracking.....	222
7.5	Speed control (S).....	226
7.5.1	Configuring speed setpoint.....	226
7.5.1.1	Speed control with external analog speed setpoint.....	226
7.5.1.2	Speed control with fixed speed setpoint.....	228
7.5.2	Direction and stop.....	228
7.5.3	Speed limit.....	229
7.5.4	Torque limit.....	229
7.5.5	Zero speed clamp.....	229
7.5.6	Ramp-function generator.....	230
7.6	Torque control (T).....	232
7.6.1	300% overload capacity.....	232
7.6.2	Torque setpoint.....	232
7.6.2.1	Torque control with external analog torque setpoint.....	233
7.6.2.2	Torque control with fixed torque setpoint.....	234
7.6.3	Direction and stop.....	234
7.6.4	Speed limit.....	234
7.7	Communicating with the PLC.....	235
7.7.1	USS communication.....	235
7.7.2	Modbus communication.....	237
7.7.2.1	Overview.....	237
7.7.2.2	Cyclic communication.....	242
7.7.2.3	Acyclic communication.....	252
7.8	Absolute position system.....	261
7.8.1	Overview.....	261
7.8.2	Transmitting sequence for the absolute position data.....	262
<b>8</b>	<b>Safety Integrated function.....</b>	<b>264</b>
8.1	Standards and regulations.....	264
8.1.1	General information.....	264
8.1.1.1	Aims.....	264
8.1.1.2	Functional safety.....	265
8.1.2	Safety of machinery in Europe.....	265
8.1.2.1	Machinery Directive.....	265
8.1.2.2	Harmonized European Standards.....	266
8.1.2.3	Standards for implementing safety-related controllers.....	267
8.1.2.4	DIN EN ISO 13849-1.....	268
8.1.2.5	EN 62061.....	269
8.1.2.6	Series of standards EN 61508 (VDE 0803).....	270
8.1.2.7	Risk analysis/assessment.....	271
8.1.2.8	Risk reduction.....	272
8.1.2.9	Residual risk.....	273
8.1.3	Machine safety in the USA.....	273
8.1.3.1	Minimum requirements of the OSHA.....	273
8.1.3.2	NRTL listing.....	274

8.1.3.3	NFPA 79 .....	274
8.1.3.4	ANSI B11 .....	275
8.1.4	Machine safety in Japan .....	276
8.1.5	Equipment regulations .....	276
8.2	General information about SINAMICS Safety Integrated .....	276
8.3	System features .....	277
8.3.1	STO functional safety data .....	277
8.3.2	Certification .....	277
8.3.3	Safety instructions.....	277
8.3.4	Probability of failure of the safety function .....	279
8.3.5	Response time .....	279
8.3.6	Residual risk .....	280
8.4	Safety Integrated basic functions.....	280
8.4.1	Safe Torque Off (STO).....	280
8.4.2	Forced dormant error detection .....	283
<b>9</b>	<b>Tuning .....</b>	<b>284</b>
9.1	Controller overview .....	284
9.2	Tuning mode .....	286
9.3	One-button auto tuning .....	287
9.4	Real-time auto tuning.....	292
9.5	Manual tuning .....	296
9.6	Resonance suppression .....	297
9.7	Low frequency vibration suppression .....	300
9.8	Gain switching.....	301
9.8.1	Gain switching using an external digital input signal (G-CHANGE) .....	302
9.8.2	Gain switching using position deviation .....	303
9.8.3	Gain switching using position setpoint frequency .....	303
9.8.4	Gain switching using actual speed .....	304
9.9	PI/P switching .....	305
9.9.1	PI/P switching using torque setpoint.....	307
9.9.2	PI/P switching using an external digital input signal (G-CHANGE) .....	307
9.9.3	PI/P switching using speed setpoint .....	308
9.9.4	PI/P switching using acceleration setpoint .....	309
9.9.5	PI/P switching using pulse deviation.....	310
<b>10</b>	<b>Parameters .....</b>	<b>311</b>
10.1	Overview .....	311
10.2	Parameter list.....	313
<b>11</b>	<b>Diagnostics .....</b>	<b>350</b>
11.1	Overview .....	350
11.2	List of faults and alarms .....	353

<b>A</b>	<b>Appendix.....</b>	<b>373</b>
A.1	Assembly of cable terminals on the drive side .....	373
A.2	Assembly of cable connectors on the motor side .....	376
A.3	Motor selection.....	383
A.3.1	Selection procedure .....	383
A.3.2	Parameter description .....	384
A.3.3	Selection examples .....	386
A.4	Replacing fans .....	387
	<b>Index .....</b>	<b>388</b>



# Fundamental safety instructions

## 1.1 General safety instructions



### **! WARNING**

#### **Electric shock and danger to life due to other energy sources**

Touching live components can result in death or severe injury.

- Only work on electrical devices when you are qualified for this job.
- Always observe the country-specific safety rules.

Generally, the following six steps apply when establishing safety:

1. Prepare for disconnection. Notify all those who will be affected by the procedure.
2. Isolate the drive system from the power supply and take measures to prevent it being switched back on again.
3. Wait until the discharge time specified on the warning labels has elapsed.
4. Check that there is no voltage between any of the power connections, and between any of the power connections and the protective conductor connection.
5. Check whether the existing auxiliary supply circuits are de-energized.
6. Ensure that the motors cannot move.
7. Identify all other dangerous energy sources, e.g. compressed air, hydraulic systems, or water. Switch the energy sources to a safe state.
8. Check that the correct drive system is completely locked.

After you have completed the work, restore the operational readiness in the inverse sequence.



### **! WARNING**

#### **Risk of electric shock and fire from supply networks with an excessively high impedance**

Excessively low short-circuit currents can lead to the protective devices not tripping or tripping too late, and thus causing electric shock or a fire.

- In the case of a conductor-conductor or conductor-ground short-circuit, ensure that the short-circuit current at the point where the inverter is connected to the line supply at least meets the minimum requirements for the response of the protective device used.
- You must use an additional residual-current device (RCD) if a conductor-ground short circuit does not reach the short-circuit current required for the protective device to respond. The required short-circuit current can be too low, especially for TT supply systems.



**! WARNING**

**Risk of electric shock and fire from supply networks with an excessively low impedance**

Excessively high short-circuit currents can lead to the protective devices not being able to interrupt these short-circuit currents and being destroyed, and thus causing electric shock or a fire.

- Ensure that the prospective short-circuit current at the line terminal of the inverter does not exceed the breaking capacity (SCCR or  $I_{cc}$ ) of the protective device used.



**! WARNING**

**Electric shock if there is no ground connection**

For missing or incorrectly implemented protective conductor connection for devices with protection class I, high voltages can be present at open, exposed parts, which when touched, can result in death or severe injury.

- Ground the device in compliance with the applicable regulations.



**! WARNING**

**Electric shock due to connection to an unsuitable power supply**

When equipment is connected to an unsuitable power supply, exposed components may carry a hazardous voltage that might result in serious injury or death.

- Only use power supplies that provide SELV (Safety Extra Low Voltage) or PELV- (Protective Extra Low Voltage) output voltages for all connections and terminals of the electronics modules.



**! WARNING**

**Electric shock due to damaged motors or devices**

Improper handling of motors or devices can damage them.

Hazardous voltages can be present at the enclosure or at exposed components on damaged motors or devices.

- Ensure compliance with the limit values specified in the technical data during transport, storage and operation.
- Do not use any damaged motors or devices.

**⚠ WARNING****Electric shock due to unconnected cable shields**

Hazardous touch voltages can occur through capacitive cross-coupling due to unconnected cable shields.

- As a minimum, connect cable shields and the cores of cables that are not used at one end at the grounded housing potential.

**⚠ WARNING****Arcing when a plug connection is opened during operation**

Opening a plug connection when a system is operation can result in arcing that may cause serious injury or death.

- Only open plug connections when the equipment is in a voltage-free state, unless it has been explicitly stated that they can be opened in operation.

**⚠ WARNING****Electric shock due to residual charges in power components**

Because of the capacitors, a hazardous voltage is present for up to 5 minutes after the power supply has been switched off. Contact with live parts can result in death or serious injury.

- Wait for 5 minutes before you check that the unit really is in a no-voltage condition and start work.

**NOTICE****Property damage due to loose power connections**

Insufficient tightening torques or vibration can result in loose power connections. This can result in damage due to fire, device defects or malfunctions.

- Tighten all power connections to the prescribed torque.
- Check all power connections at regular intervals, particularly after equipment has been transported.

 **WARNING**

**Spread of fire from built-in devices**

In the event of fire outbreak, the enclosures of built-in devices cannot prevent the escape of fire and smoke. This can result in serious personal injury or property damage.

- Install built-in units in a suitable metal cabinet in such a way that personnel are protected against fire and smoke, or take other appropriate measures to protect personnel.
- Ensure that smoke can only escape via controlled and monitored paths.

 **WARNING**

**Active implant malfunctions due to electromagnetic fields**

Inverters generate electromagnetic fields (EMF) in operation. People with active implants in the immediate vicinity of this equipment are at particular risk.

- As the operator of an EMF-emitting installation, assess the individual risks of persons with active implants. The following clearances are usually adequate:
  - No clearance to closed control cabinets and shielded MOTION-CONNECT supply cables
  - Forearm length (approx. 35 cm clearance) to distributed drive systems and open control cabinets

 **WARNING**

**Active implant malfunctions due to permanent-magnet fields**

Even when switched off, electric motors with permanent magnets represent a potential risk for persons with heart pacemakers or implants if they are close to converters/motors.

- If you have a heart pacemaker or implant, maintain a minimum distance of 2 m.
- When transporting or storing permanent-magnet motors always use the original packing materials with the warning labels attached.
- Clearly mark the storage locations with the appropriate warning labels.
- IATA regulations must be observed when transported by air.

 **WARNING**

**Unexpected movement of machines caused by radio devices or mobile phones**

When radio devices or mobile phones with a transmission power  $> 1 \text{ W}$  are used in the immediate vicinity of components, they may cause the equipment to malfunction. Malfunctions may impair the functional safety of machines and can therefore put people in danger or lead to property damage.

- If you come closer than around 2 m to such components, switch off any radios or mobile phones.
- Use the "SIEMENS Industry Online Support app" only on equipment that has already been switched off.

**NOTICE****Damage to motor insulation due to excessive voltages**

When operated on systems with grounded line conductor or in the event of a ground fault in the IT system, the motor insulation can be damaged by the higher voltage to ground. If you use motors that have insulation that is not designed for operation with grounded line conductors, you must perform the following measures:

- IT system: Use a ground fault monitor and eliminate the fault as quickly as possible.
- TN or TT systems with grounded line conductor: Use an isolating transformer on the line side.

 **WARNING****Fire due to inadequate ventilation clearances**

Inadequate ventilation clearances can cause overheating of components with subsequent fire and smoke. This can cause severe injury or even death. This can also result in increased downtime and reduced service lives for devices/systems.

- Ensure compliance with the specified minimum clearance as ventilation clearance for the respective component.

 **WARNING****Unrecognized dangers due to missing or illegible warning labels**

Dangers might not be recognized if warning labels are missing or illegible. Unrecognized dangers may cause accidents resulting in serious injury or death.

- Check that the warning labels are complete based on the documentation.
- Attach any missing warning labels to the components, where necessary in the national language.
- Replace illegible warning labels.

**NOTICE****Device damage caused by incorrect voltage/insulation tests**

Incorrect voltage/insulation tests can damage the device.

- Before carrying out a voltage/insulation check of the system/machine, disconnect the devices as all converters and motors have been subject to a high voltage test by the manufacturer, and therefore it is not necessary to perform an additional test within the system/machine.

 **WARNING**

**Unexpected movement of machines caused by inactive safety functions**

Inactive or non-adapted safety functions can trigger unexpected machine movements that may result in serious injury or death.

- Observe the information in the appropriate product documentation before commissioning.
- Carry out a safety inspection for functions relevant to safety on the entire system, including all safety-related components.
- Ensure that the safety functions used in your drives and automation tasks are adjusted and activated through appropriate parameterizing.
- Perform a function test.
- Only put your plant into live operation once you have guaranteed that the functions relevant to safety are running correctly.

**Note**

**Important safety notices for Safety Integrated functions**

If you want to use Safety Integrated functions, you must observe the safety notices in the Safety Integrated manuals.

 **WARNING**

**Malfunctions of the machine as a result of incorrect or changed parameter settings**

As a result of incorrect or changed parameterization, machines can malfunction, which in turn can lead to injuries or death.

- Protect the parameterization (parameter assignments) against unauthorized access.
- Handle possible malfunctions by taking suitable measures, e.g. emergency stop or emergency off.

 **WARNING**

**Injury caused by moving or ejected parts**

Contact with moving motor parts or drive output elements and the ejection of loose motor parts (e.g. feather keys) out of the motor enclosure can result in severe injury or death.

- Remove any loose parts or secure them so that they cannot be flung out.
- Do not touch any moving parts.
- Safeguard all moving parts using the appropriate safety guards.

 **WARNING****Fire due to inadequate cooling**

Inadequate cooling can cause the motor to overheat, resulting in death or severe injury as a result of smoke and fire. This can also result in increased failures and reduced service lives of motors.

- Comply with the specified cooling requirements for the motor.

 **WARNING****Fire due to incorrect operation of the motor**

When incorrectly operated and in the case of a fault, the motor can overheat resulting in fire and smoke. This can result in severe injury or death. Further, excessively high temperatures destroy motor components and result in increased failures as well as shorter service lives of motors.

- Operate the motor according to the relevant specifications.
- Only operate the motors in conjunction with effective temperature monitoring.
- Immediately switch off the motor if excessively high temperatures occur.

 **CAUTION****Burn injuries caused by hot surfaces**

In operation, the motor can reach high temperatures, which can cause burns if touched.

- Mount the motor so that it is not accessible in operation.

Measures when maintenance is required:

- Allow the motor to cool down before starting any work.
- Use the appropriate personnel protection equipment, e.g. gloves.

## 1.2 Equipment damage due to electric fields or electrostatic discharge

Electrostatic sensitive devices (ESD) are individual components, integrated circuits, modules or devices that may be damaged by either electric fields or electrostatic discharge.



### NOTICE

#### Equipment damage due to electric fields or electrostatic discharge

Electric fields or electrostatic discharge can cause malfunctions through damaged individual components, integrated circuits, modules or devices.

- Only pack, store, transport and send electronic components, modules or devices in their original packaging or in other suitable materials, e.g. conductive foam rubber or aluminum foil.
- Only touch components, modules and devices when you are grounded by one of the following methods:
  - Wearing an ESD wrist strap
  - Wearing ESD shoes or ESD grounding straps in ESD areas with conductive flooring
- Only place electronic components, modules or devices on conductive surfaces (table with ESD surface, conductive ESD foam, ESD packaging, ESD transport container).

## 1.3 Warranty and liability for application examples

Application examples are not binding and do not claim to be complete regarding configuration, equipment or any eventuality which may arise. Application examples do not represent specific customer solutions, but are only intended to provide support for typical tasks.

As the user you yourself are responsible for ensuring that the products described are operated correctly. Application examples do not relieve you of your responsibility for safe handling when using, installing, operating and maintaining the equipment.



## 1.4 Industrial security

### Note

#### Industrial security

Siemens provides products and solutions with industrial security functions that support the secure operation of plants, systems, machines and networks.

In order to protect plants, systems, machines and networks against cyber threats, it is necessary to implement – and continuously maintain – a holistic, state-of-the-art industrial security concept. Siemens' products and solutions constitute one element of such a concept.

Customers are responsible for preventing unauthorized access to their plants, systems, machines and networks. Such systems, machines and components should only be connected to an enterprise network or the Internet if and to the extent such a connection is necessary and only when appropriate security measures (e.g. firewalls and/or network segmentation) are in place.

For additional information on industrial security measures that may be implemented, please visit:

Industrial security (<http://www.siemens.com/industrialsecurity>)

Siemens' products and solutions undergo continuous development to make them more secure. Siemens strongly recommends that product updates are applied as soon as they are available and that the latest product versions are used. Use of product versions that are no longer supported, and failure to apply the latest updates may increase customer's exposure to cyber threats.

To stay informed about product updates, subscribe to the Siemens Industrial Security RSS Feed at:

Industrial security (<http://www.siemens.com/industrialsecurity>)

Further information is provided on the Internet:

Industrial Security Configuration Manual

(<https://support.industry.siemens.com/cs/ww/en/view/108862708>)

### WARNING

#### Unsafe operating states resulting from software manipulation

Software manipulations (e.g. viruses, trojans, malware or worms) can cause unsafe operating states in your system that may lead to death, serious injury, and property damage.

- Keep the software up to date.
- Incorporate the automation and drive components into a holistic, state-of-the-art industrial security concept for the installation or machine.
- Make sure that you include all installed products into the holistic industrial security concept.
- Protect files stored on exchangeable storage media from malicious software by with suitable protection measures, e.g. virus scanners.
- Protect the drive against unauthorized changes by activating the "know-how protection" drive function.

## 1.5 Residual risks of power drive systems

When assessing the machine- or system-related risk in accordance with the respective local regulations (e.g., EC Machinery Directive), the machine manufacturer or system installer must take into account the following residual risks emanating from the control and drive components of a drive system:

1. Unintentional movements of driven machine or system components during commissioning, operation, maintenance, and repairs caused by, for example,
  - Hardware and/or software errors in the sensors, control system, actuators, and cables and connections
  - Response times of the control system and of the drive
  - Operation and/or environmental conditions outside the specification
  - Condensation/conductive contamination
  - Parameterization, programming, cabling, and installation errors
  - Use of wireless devices/mobile phones in the immediate vicinity of electronic components
  - External influences/damage
  - X-ray, ionizing radiation and cosmic radiation
2. Unusually high temperatures, including open flames, as well as emissions of light, noise, particles, gases, etc., can occur inside and outside the components under fault conditions caused by, for example:
  - Component failure
  - Software errors
  - Operation and/or environmental conditions outside the specification
  - External influences/damage
3. Hazardous shock voltages caused by, for example:
  - Component failure
  - Influence during electrostatic charging
  - Induction of voltages in moving motors
  - Operation and/or environmental conditions outside the specification
  - Condensation/conductive contamination
  - External influences/damage
4. Electrical, magnetic and electromagnetic fields generated in operation that can pose a risk to people with a pacemaker, implants or metal replacement joints, etc., if they are too close
5. Release of environmental pollutants or emissions as a result of improper operation of the system and/or failure to dispose of components safely and correctly
6. Influence of network-connected communication systems, e.g. ripple-control transmitters or data communication via the network

For more information about the residual risks of the drive system components, see the relevant sections in the technical user documentation.

## General information

The SINAMICS V90 drives are available in two variants, 400 V variant and 200 V variant.



The 200 V variant is available in four frame sizes: FSA, FSB, FSC, and FSD. Frame sizes A, B, and C are used on the single phase or three phase power network while frame size D is used on the three phase power network only.

The 400 V variant is also available in four frame sizes: FSAA, FSA, FSB, and FSC. All the frame sizes are used on three phase power network only.



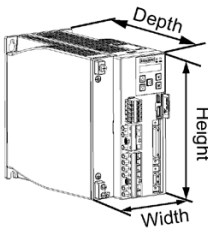

### 2.1 Scope of delivery

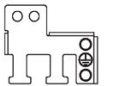
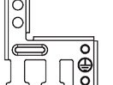
#### 2.1.1 Drive components

##### Components in SINAMICS V90 200 V variant drive package

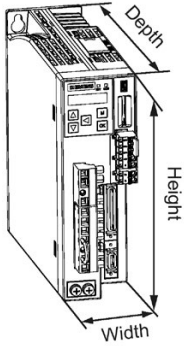
Component	Illustration	Rated power (kW)	Outline dimension (Width x Height x Depth, mm)	Frame size	Article number
SINAMICS V90, single/three-phase, 200 V		0.1/0.2	45 x 170 x 170	FSA	6SL3210-5FB10-1UA2 6SL3210-5FB10-2UA2
		0.4	55 x 170 x 170	FSB	6SL3210-5FB10-4UA1
		0.75	80 x 170 x 195	FSC	6SL3210-5FB10-8UA0
SINAMICS V90, three-phase, 200 V		1.0/1.5/2.0	95 x 170 x 195	FSD	6SL3210-5FB11-0UA1
					6SL3210-5FB11-5UA0
					6SL3210-5FB12-0UA0
Connectors		For FSA and FSB			
		For FSC and FSD			
Shielding plate		For FSA and FSB			
		For FSC and FSD			
User documentation	Information Guide	English-Chinese bilingual version			

Components in SINAMICS V90 400 V variant drive package

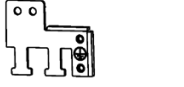
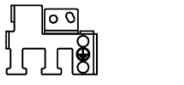
Component	Illustration	Rated power (kW)	Outline dimension (Width x Height x Depth, mm)	Frame size	Article number
SINAMICS V90, three-phase, 400 V		0.4	60 x 180 x 200	FSAA	6SL3210-5FE10-4UA0
		0.75/1.0	80 x 180 x 200	FSA	6SL3210-5FE10-8UA0 6SL3210-5FE11-0UA0
		1.5/2.0	100 x 180 x 220	FSB	6SL3210-5FE11-5UA0 6SL3210-5FE12-0UA0
		3.5/5.0/7.0	140 x 260 x 240	FSC	6SL3210-5FE13-5UA0
					6SL3210-5FE15-0UA0
					6SL3210-5FE17-0UA0
		Connectors		For FSAA	
	For FSA				
	For FSB and FSC				
Shielding plate		For FSAA and FSA			
		For FSB and FSC			
User documentation	Information Guide	English-Chinese bilingual version			

Drive rating plate (example)

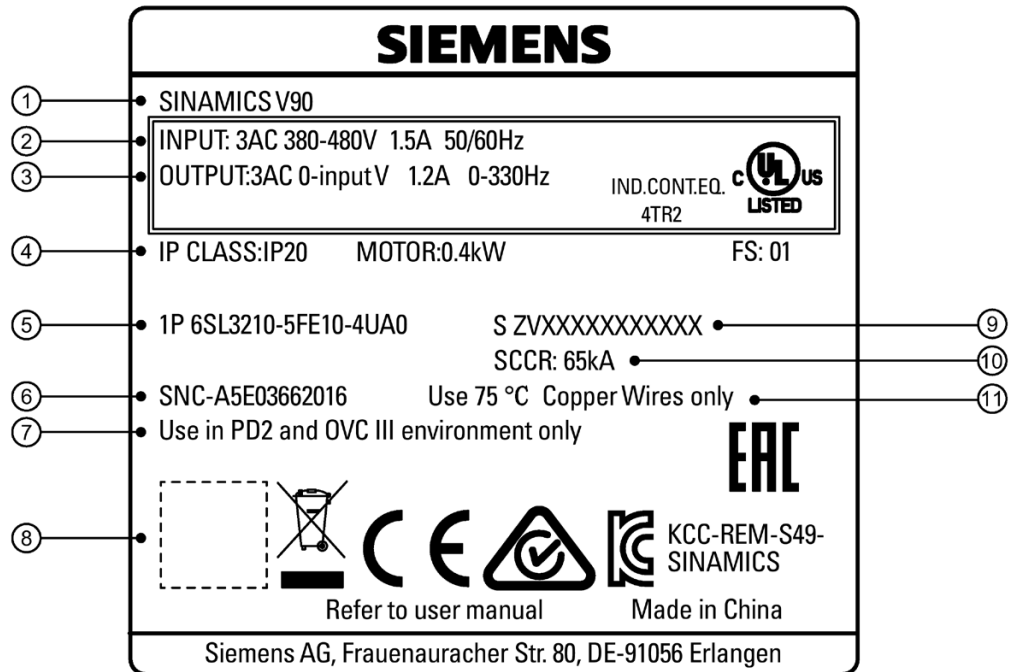

- |   |                   |   |   |
|---|-------------------|---|---|
| ① | Drive name        | ⑦ | Pollution degree and overvoltage criteria |
| ② | Power input       | ⑧ | QR code                                   |
| ③ | Power output      | ⑨ | Product serial number                     |
| ④ | Rated motor power | ⑩ | Rated short-circuit current               |
| ⑤ | Article number    | ⑪ | Copper wire                               |
| ⑥ | Part number       |   |   |

Article number explanation (example)

**6 S L 3 2 1 0 - 5 F E 1 0 - 4 U A 0**

Supply voltage

Symbol	Supply voltage
B	1/3 phase 200~240 VAC
E	3 phase 380~480 VAC

Drive version

Symbol	Drive version
A	V90 Pulse train (PTI) version
F	V90 PROFINET (PN) version

Supported max motor power

Symbol	Supported max motor power	Supply voltage
10-1	0.1 kW	200 V
10-2	0.2 kW	200 V
10-4	0.4 kW	200 V
	0.4 kW	400 V
10-8	0.75 kW	200 V
	0.75 kW	400 V
11-0	1.0 kW	200 V
	1.0 kW	400 V
11-5	1.5 kW	200 V
	1.75 kW	400 V
12-0	2.0 kW	200 V
	2.5 kW	400 V
13-5	3.5 kW	400 V
15-0	5.0 kW	400 V
17-0	7.0 kW	400 V

Serial number explanation (example)

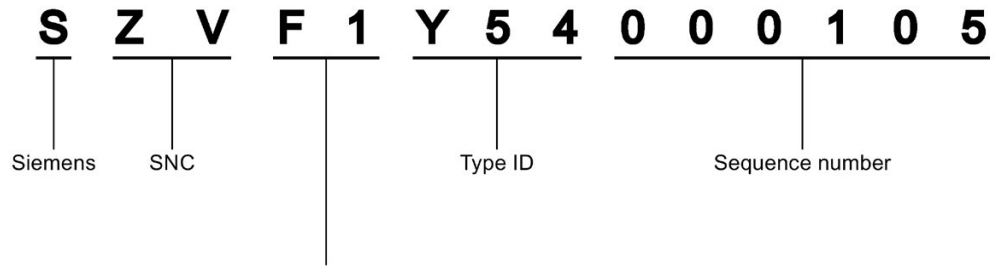

Production date (year/month)

Code	Calendar year	Code	Month
A	2010, 2030	1	January
B	2011, 2031	2	February
C	2012, 2032	3	March
D	2013, 2033	4	April
E	2014, 2034	5	May
F	2015, 2035	6	June
H	2016, 2036	7	July
J	2017, 2037	8	August
K	2018, 2038	9	September
L	2019, 2039	0	October
M	2020, 2040	N	November
N	2021, 2041	D	December
P	2022, 2042		
R	2023, 2043		
S	2024, 2044		
T	2025, 2045		
U	2026, 2046		
V	2027, 2047		
W	2028, 2048		
X	2029, 2049		

2.1.2 Motor components

Components in the SIMOTICS S-1FL6 low inertia motor package

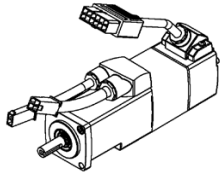
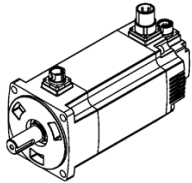
Component	Illustration	Rated power (kW)	Shaft height (mm)	Article number	
SIMOTICS S-1FL6, low inertia		0.05/0.1	20	1FL6022-2AF21-1□□1 1FL6024-2AF21-1□□1	
		0.2/0.4	30	1FL6032-2AF21-1□□1 1FL6034-2AF21-1□□1	
		0.75/1.0	40	1FL6042-2AF21-1□□1 1FL6044-2AF21-1□□1	
				1FL6052-2AF21-0□□1 1FL6054-2AF21-0□□1	
		1.5/2.0	50	1FL6052-2AF21-2□□1 1FL6054-2AF21-2□□1	
		1.5/2.0	50	1FL6052-2AF21-2□□1 1FL6054-2AF21-2□□1	
	User documentation	SIMOTICS S-1FL6 Servo Motors Installation Guide			

**Note:** For the SH50 motors with a multi-turn absolute encoder, only angular connector version is available.

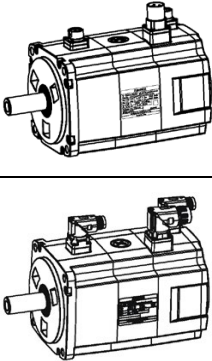

### Components in the SIMOTICS S-1FL6 high inertia motor package

Component	Illustration	Rated power (kW)	Shaft height (mm)	Article number				
SIMOTICS S-1FL6, high inertia		0.4/0.75	45	1FL6042-1AF61-	<input type="checkbox"/>	□□1		
				1FL6044-1AF61-	<input type="checkbox"/>	□□1		
		0.75/1.0/1.5/1.7 5/2.0	65	1FL6061-1AC61-	<input type="checkbox"/>	□□1		
				1FL6062-1AC61-	<input type="checkbox"/>	□□1		
				1FL6064-1AC61-	<input type="checkbox"/>	□□1		
				1FL6066-1AC61-	<input type="checkbox"/>	□□1		
				1FL6067-1AC61-	<input type="checkbox"/>	□□1		
		2.5/3.5/5.0/7.0	90	1FL6090-1AC61-	<input type="checkbox"/>	□□1		
				1FL6092-1AC61-	<input type="checkbox"/>	□□1		
				1FL6094-1AC61-	<input type="checkbox"/>	□□1		
				1FL6096-1AC61-	<input type="checkbox"/>	□□1		
				Straight connectors with a fixed outlet direction			0	
				Angular connectors with a flexible outlet direction			2	
		User documentation	SIMOTICS S-1FL6 Servo Motors Installation Guide					

Motor rating plate (example)

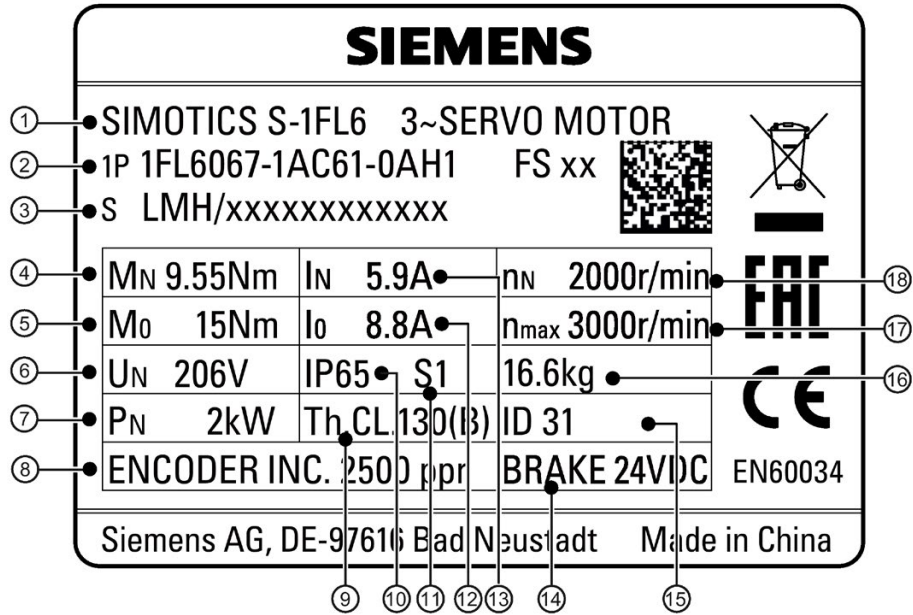

- |                               |                        |
|-------------------------------|------------------------|
| ① Motor type                  | ⑩ Degree of protection |
| ② Article number              | ⑪ Motor operating mode |
| ③ Serial number               | ⑫ Stall current        |
| ④ Rated torque                | ⑬ Rated current        |
| ⑤ Stall torque                | ⑭ Holding brake        |
| ⑥ Rated voltage               | ⑮ Motor ID             |
| ⑦ Rated power                 | ⑯ Weight               |
| ⑧ Encoder type and resolution | ⑰ Maximum speed        |
| ⑨ Thermal class               | ⑱ Rated speed          |

Article number explanation

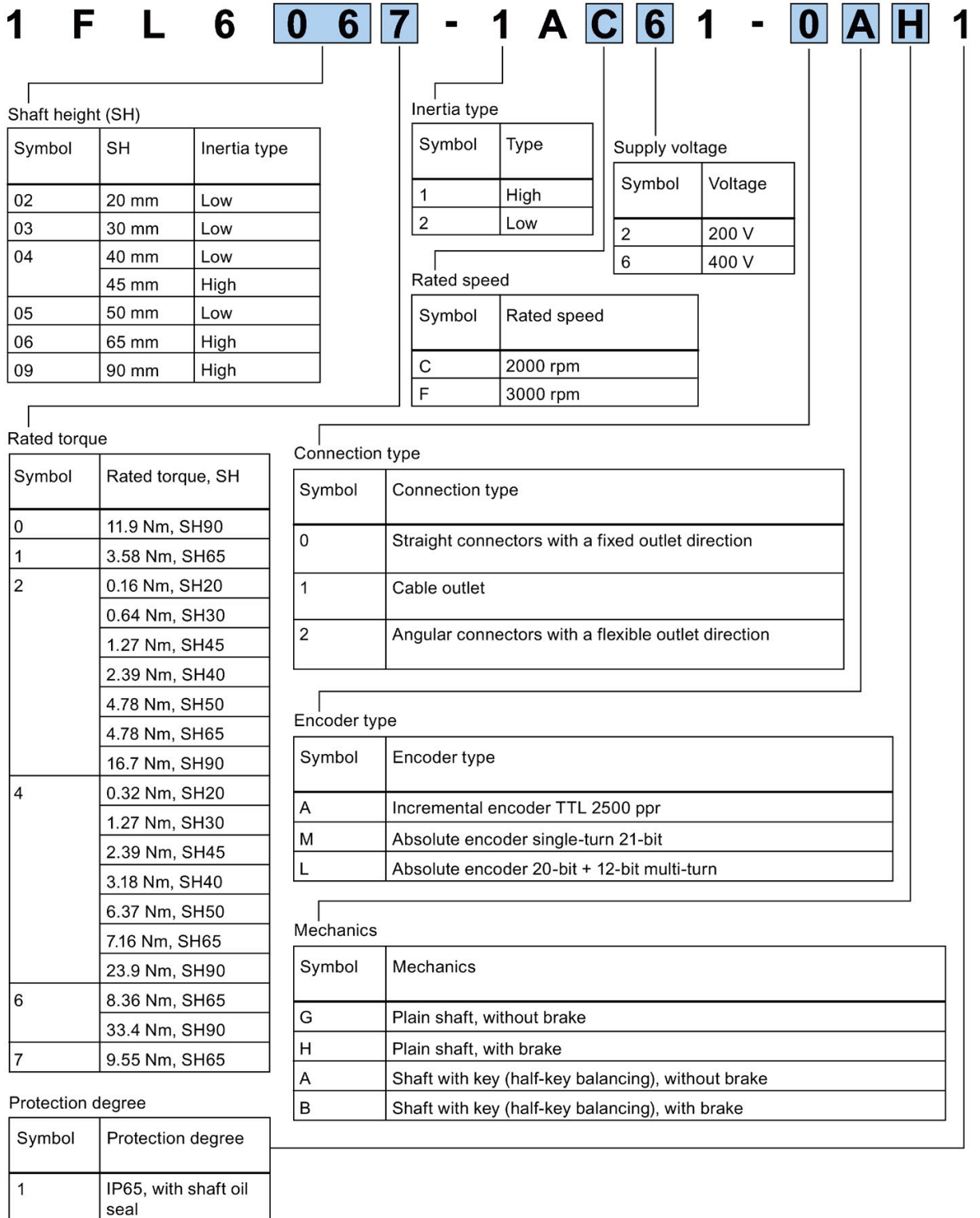

## 2.2 Device combination

### V90 200 V servo system

SIMOTICS S-1FL6 low inertia servo motors					SINAMICS V90 200 V servo drives			MOTION-CONNECT 300 pre-assembled cables				
Rated torque (Nm)	Rated power (kW)	Rated speed (rpm)	Shaft height (mm)	Article No. 1FL60			Article No. 6SL3210-5	Frame size	Article No. 6FX3002-5	Article No. 6FX3002-5	Article No. 6FX3002-2	
0.16	0.05	3000	20	22-2AF21-1	<input type="checkbox"/>	<input type="checkbox"/> 1	FB10-1UA2	FSA	CK01-....	BK02-....	<input type="checkbox"/> <input type="checkbox"/>	20-....
0.32	0.1	3000		24-2AF21-1	<input type="checkbox"/>	<input type="checkbox"/> 1						
0.64	0.2	3000	30	32-2AF21-1	<input type="checkbox"/>	<input type="checkbox"/> 1	FB10-2UA2	FSB				
1.27	0.4	3000		34-2AF21-1	<input type="checkbox"/>	<input type="checkbox"/> 1	FB10-4UA1					
2.39	0.75	3000	40	42-2AF21-1	<input type="checkbox"/>	<input type="checkbox"/> 1	FB10-8UA0	FSC				
3.18	1	3000		44-2AF21-1	<input type="checkbox"/>	<input type="checkbox"/> 1	FB11-0UA1	FSD				
4.78	1.5	3000	50	52-2AF21-0 <sup>1)</sup>	<input type="checkbox"/>	<input type="checkbox"/> 1	FB11-5UA0	CK31-....	BL02-....	<input type="checkbox"/> <input type="checkbox"/>	10-....	
6.37	2	3000		54-2AF21-0 <sup>1)</sup>	<input type="checkbox"/>	<input type="checkbox"/> 1	FB12-0UA0					
4.78	1.5	3000	50	52-2AF21-2 <sup>2)</sup>	<input type="checkbox"/>	<input type="checkbox"/> 1	FB11-5UA0	CK32-....	BL03-....	<input type="checkbox"/> <input type="checkbox"/>	12-....	
6.37	2	3000		54-2AF21-2 <sup>2)</sup>	<input type="checkbox"/>	<input type="checkbox"/> 1	FB12-0UA0					
Incremental encoder TTL 2500 ppr					A				Incremental encoder TTL 2500 ppr		CT	
Absolute encoder single-turn 21-bit					M				Absolute encoder single-turn 21-bit		DB	
Absolute encoder 20-bit + 12-bit multi-turn					L				Absolute encoder 20-bit + 12-bit multi-turn			
<b>Cable length</b> <sup>3)</sup>												
3 m								1AD0				
5 m								1AF0				
10 m								1BA0				
20 m								1CA0				

- 1) Low inertia motor with straight connectors
- 2) Low inertia motor with angular connectors
- 3) The last four numbers in the cable article number (....)

## V90 400 V servo system

SIMOTICS S-1FL6 high inertia servo motors with straight connectors					SINAMICS V90 400 V servo drives			MOTION-CONNECT 300 pre-assembled cables					
Rated torque (Nm)	Rated power (kW)	Rated speed (rpm)	Shaft height (mm)	Article No. 1FL60			Article No. 6SL3210-5	Frame size	Power cable	Brake cable	Encoder cable		
									Article No. 6FX3002-5	Article No. 6FX3002-5	Article No. 6FX3002-2		
1.27	0.4	3000	45	42-1AF61-0	<input type="checkbox"/>	<input type="checkbox"/>	FE10-4UA0	FSA	CL01-....	BL02-....	<input type="checkbox"/>	10-....	
2.39	0.75	3000		44-1AF61-0	<input type="checkbox"/>	<input type="checkbox"/>	FE10-8UA0	FSA					
3.58	0.75	2000	65	61-1AC61-0	<input type="checkbox"/>	<input type="checkbox"/>	FE11-0UA0						
4.78	1.0	2000		62-1AC61-0	<input type="checkbox"/>	<input type="checkbox"/>							
7.16	1.5	2000		64-1AC61-0	<input type="checkbox"/>	<input type="checkbox"/>	FE11-5UA0	FSB	CL11-....				
8.36	1.75	2000		66-1AC61-0	<input type="checkbox"/>	<input type="checkbox"/>							
9.55	2.0	2000		67-1AC61-0	<input type="checkbox"/>	<input type="checkbox"/>	FE12-0UA0						
11.9	2.5	2000		90-1AC61-0	<input type="checkbox"/>	<input type="checkbox"/>							
16.7	3.5	2000	90	92-1AC61-0	<input type="checkbox"/>	<input type="checkbox"/>	FE13-5UA0	FSC					
23.9	5.0	2000		94-1AC61-0	<input type="checkbox"/>	<input type="checkbox"/>	FE15-0UA0						
33.4	7.0	2000		96-1AC61-0	<input type="checkbox"/>	<input type="checkbox"/>	FE17-0UA0						
Incremental encoder TTL 2500 ppr					A				Incremental encoder TTL 2500 ppr	CT			
Absolute encoder 20-bit + 12-bit multi-turn					L				Absolute encoder 20-bit + 12-bit multi-turn	DB			
<b>Cable length <sup>1)</sup></b>													
3 m								1AD0					
5 m								1AF0					
7 m								1AH0					
10 m								1BA0					
15 m								1BF0					
20 m								1CA0					

<sup>1)</sup> The last four numbers in the cable article number (....)

SIMOTICS S-1FL6 high inertia servo motors with angular connectors						SINAMICS V90 400 V servo drives			MOTION-CONNECT 300 pre-assembled cables			
Rated torque (Nm)	Rated power (kW)	Rated speed (rpm)	Shaft height (mm)	Article No. 1FL60			Article No. 6SL3210-5	Frame size	Power cable	Brake cable	Encoder cable	
									Article No. 6FX3002-5	Article No. 6FX3002-5	Article No. 6FX3002-2	
1.27	0.4	3000	45	42-1AF61-2	<input type="checkbox"/>	<input type="checkbox"/>	FE10-4UA0	FSA	CL02-....	BL03-....	<input type="checkbox"/> <input type="checkbox"/> <input type="checkbox"/> <input type="checkbox"/>	-....
2.39	0.75	3000		44-1AF61-2	<input type="checkbox"/>	<input type="checkbox"/>	FE10-8UA0	FSA				
3.58	0.75	2000	65	61-1AC61-2	<input type="checkbox"/>	<input type="checkbox"/>	FE11-0UA0	FSB	CL12-....			
4.78	1.0	2000		62-1AC61-2	<input type="checkbox"/>	<input type="checkbox"/>						
7.16	1.5	2000		64-1AC61-2	<input type="checkbox"/>	<input type="checkbox"/>	FE11-5UA0					
8.36	1.75	2000		66-1AC61-2	<input type="checkbox"/>	<input type="checkbox"/>						
9.55	2.0	2000	90	67-1AC61-2	<input type="checkbox"/>	<input type="checkbox"/>	FE12-0UA0	FSC				
11.9	2.5	2000		90-1AC61-2	<input type="checkbox"/>	<input type="checkbox"/>						
16.7	3.5	2000		92-1AC61-2	<input type="checkbox"/>	<input type="checkbox"/>	FE13-5UA0					
23.9	5.0	2000		94-1AC61-2	<input type="checkbox"/>	<input type="checkbox"/>	FE15-0UA0					
33.4	7.0	2000		96-1AC61-2	<input type="checkbox"/>	<input type="checkbox"/>	FE17-0UA0					
Incremental encoder TTL 2500 ppr						A			Incremental encoder TTL 2500 ppr	CT12		
Absolute encoder 20-bit + 12-bit multi-turn						L			Absolute encoder 20-bit + 12-bit multi-turn	DB10		
<b>Cable length <sup>1)</sup></b>												
3 m									1AD0			
5 m									1AF0			
7 m									1AH0			
10 m									1BA0			
15 m									1BF0			
20 m									1CA0			

<sup>1)</sup> The last four numbers in the cable article number (....)

**Note**

You can select a SINAMICS V90 servo drive for all the SIMOTICS S-1FL6 servo motors whose rated power values are equal to or smaller than that specified as matching with this servo drive in the table above.

**Note**

Check the motor ID in the drive (p29000) and make sure that the value is that specified on the rating plate of the connected motor, especially when the drive is working with a motor whose rated power value is lower than that of this drive.

## 2.3 Product overview

### SINAMICS V90 servo drives

- SINAMICS V90 200 V variant  
FSA and FSB

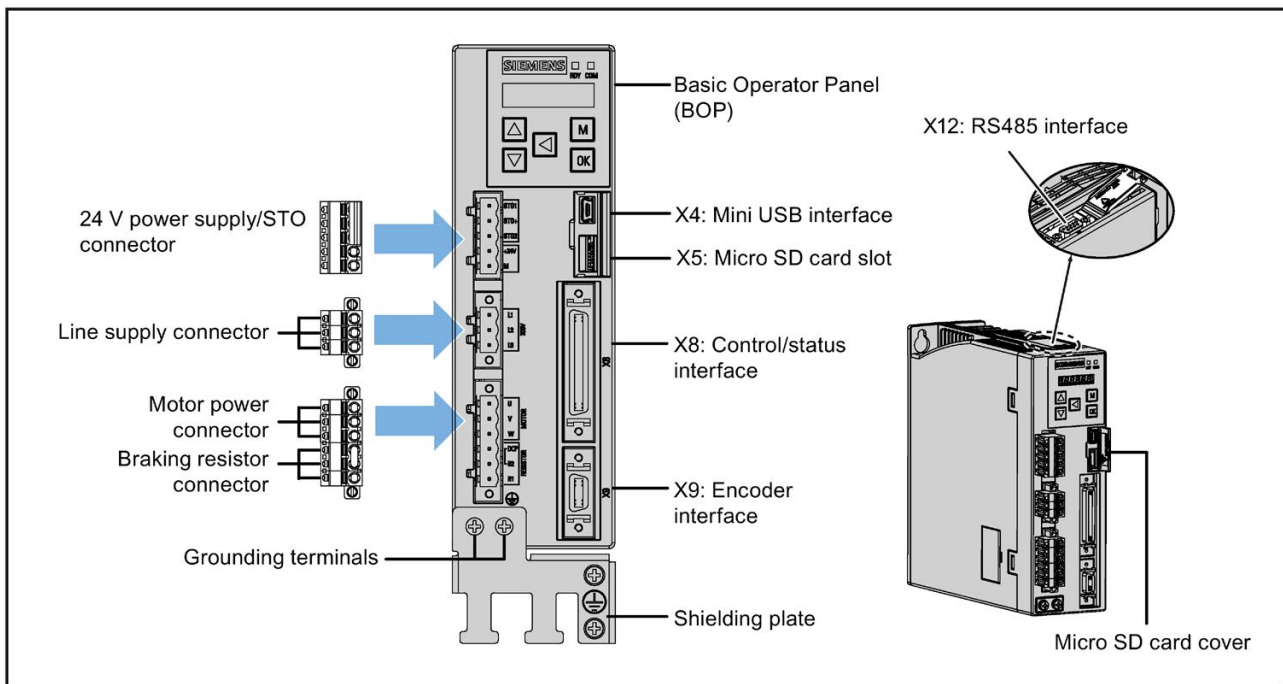

### FSC and FSD

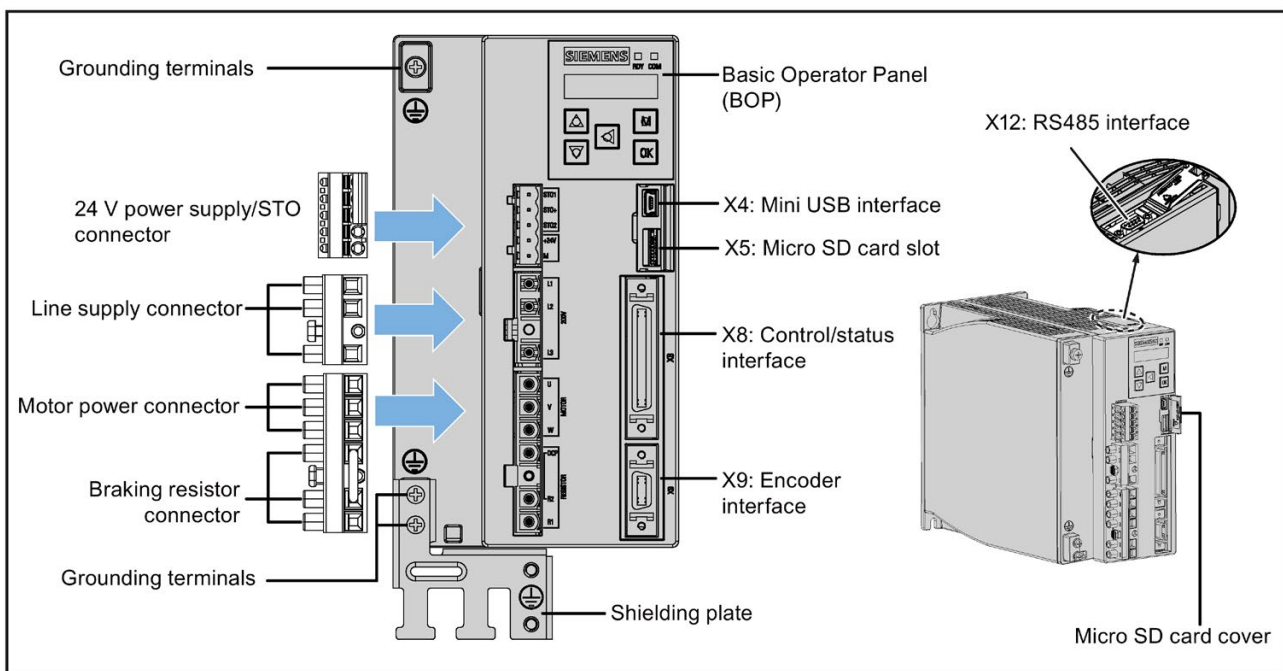

- SINAMICS V90 400V variant  
FSA and FSA

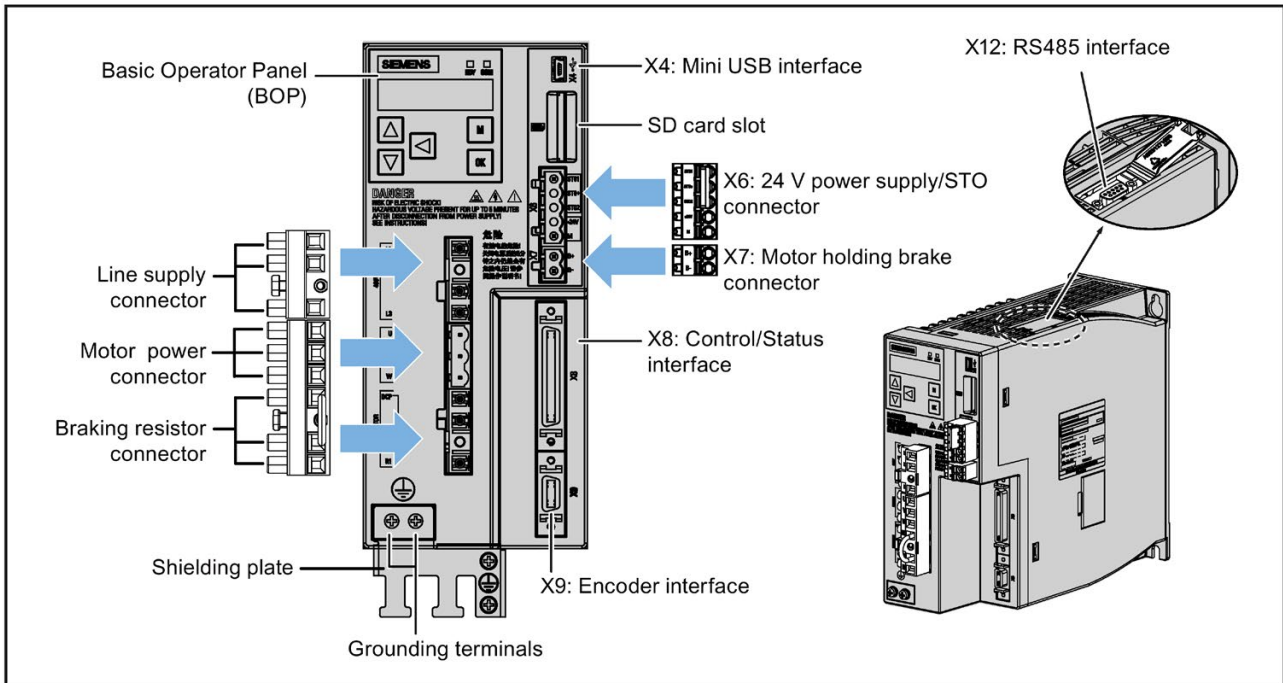

FSB and FSC

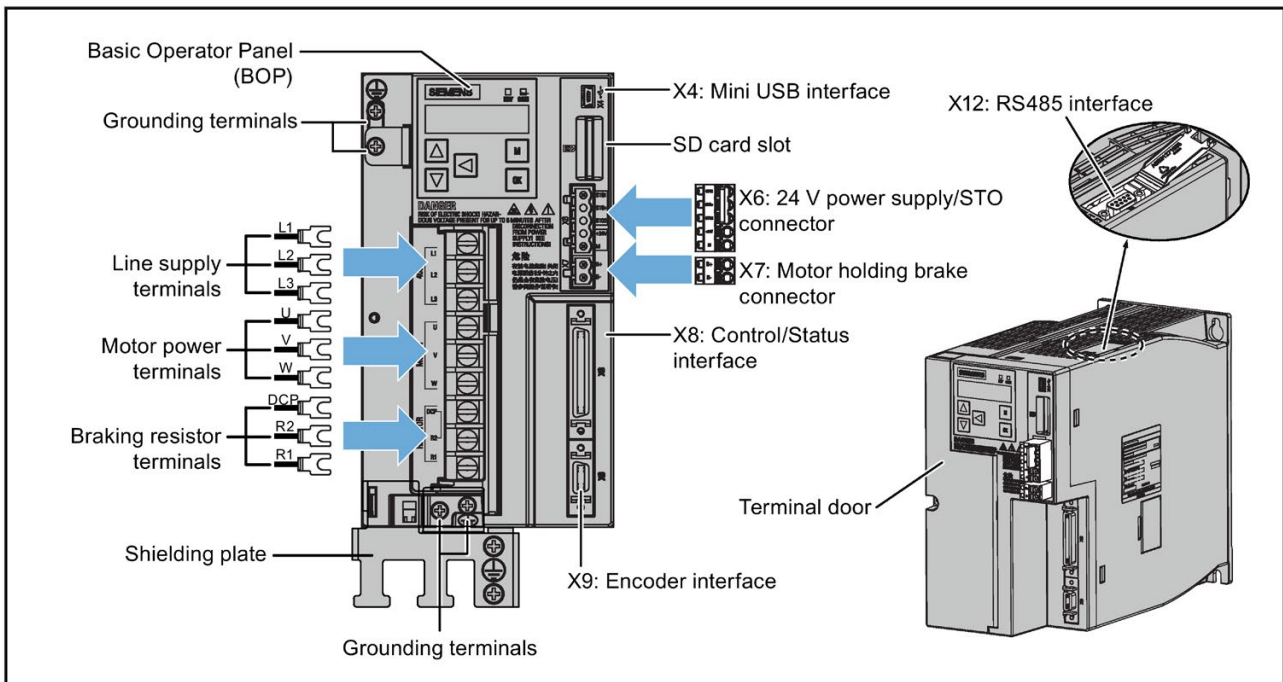



## SIMOTICS S-1FL6 servo motors

- Low inertia motors

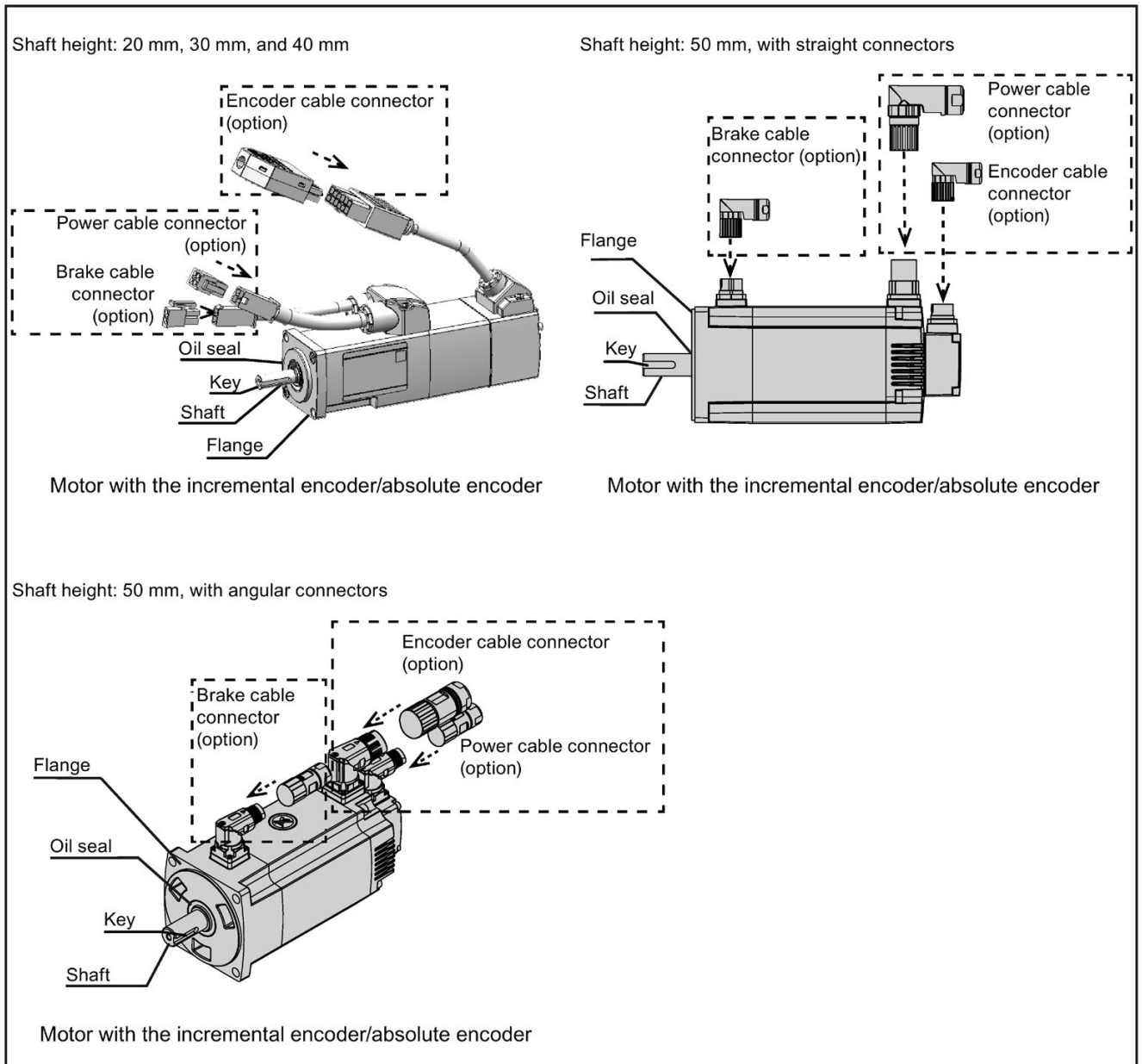

### Note

For the SH50 motors with a multi-turn absolute encoder, only angular connector version is available.

- High inertia motors with straight connectors

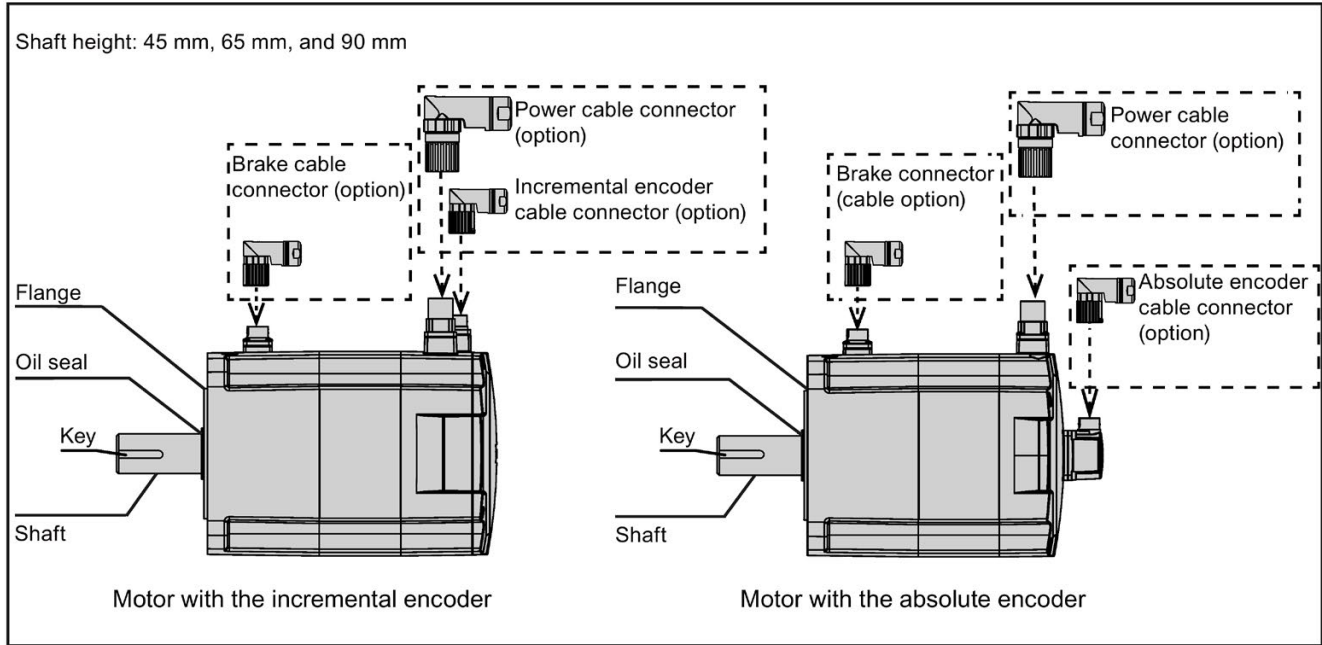

- High inertia motors with angular connectors

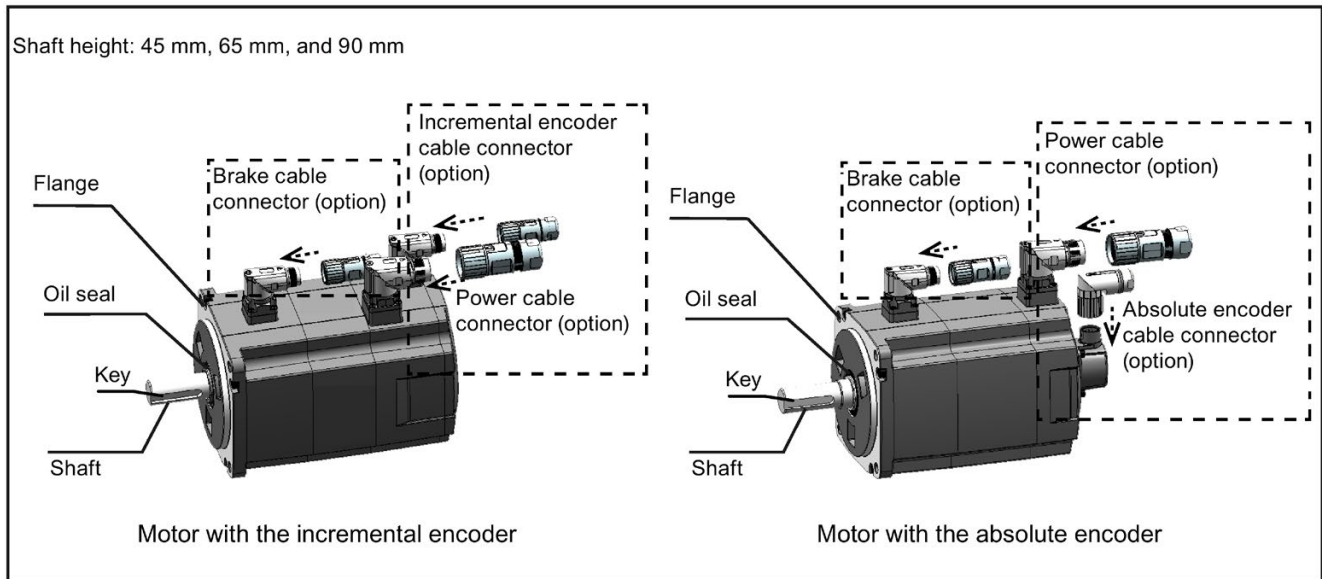

## 2.4 System configuration

The SINAMICS V90 servo drive is integrated with digital input/output interface, pulse train interface and analog interface. It can be connected either to a Siemens controller like S7-200, S7-1200 or S7-200 SMART, or to a third-party controller. Absolute position information can be read from the servo drive by the PLC via RS485 port.

A configuration software tool, SINAMICS V-ASSISTANT, can be installed on a PC. The PC can communicate with SINAMICS V90 servo drive with a USB cable for performing parameter settings, trial run, status display monitoring, gain adjustments, and so on.

The following illustrations show examples of the SINAMICS V90 servo system configuration:

### SINAMICS V90 200 V variant

The configuration for FSB when used on the single phase power network:

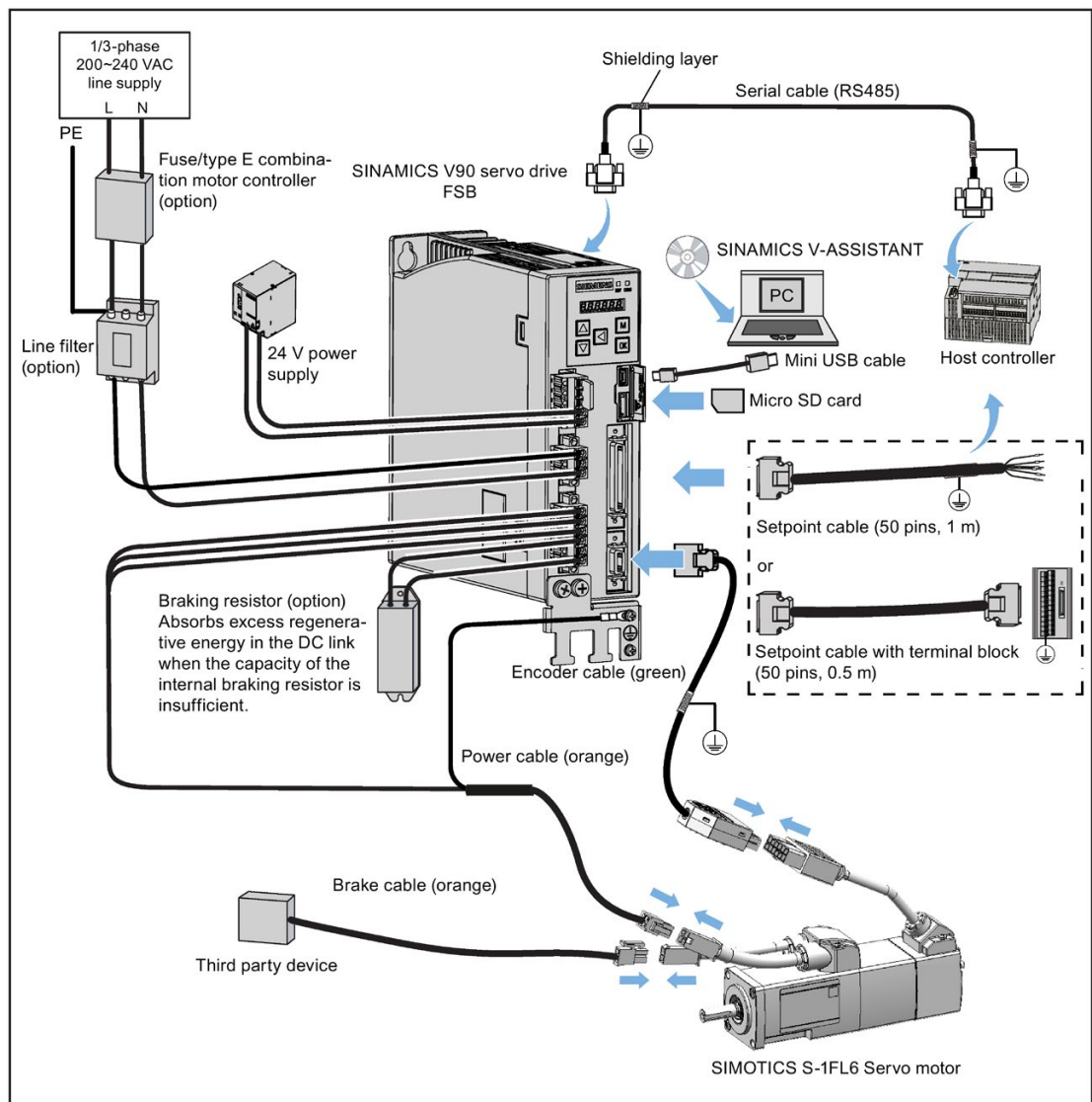

2.4 System configuration

The configuration for FSD which connects to the low inertia servo motor of 50 mm shaft-height when used on the three phase power network:

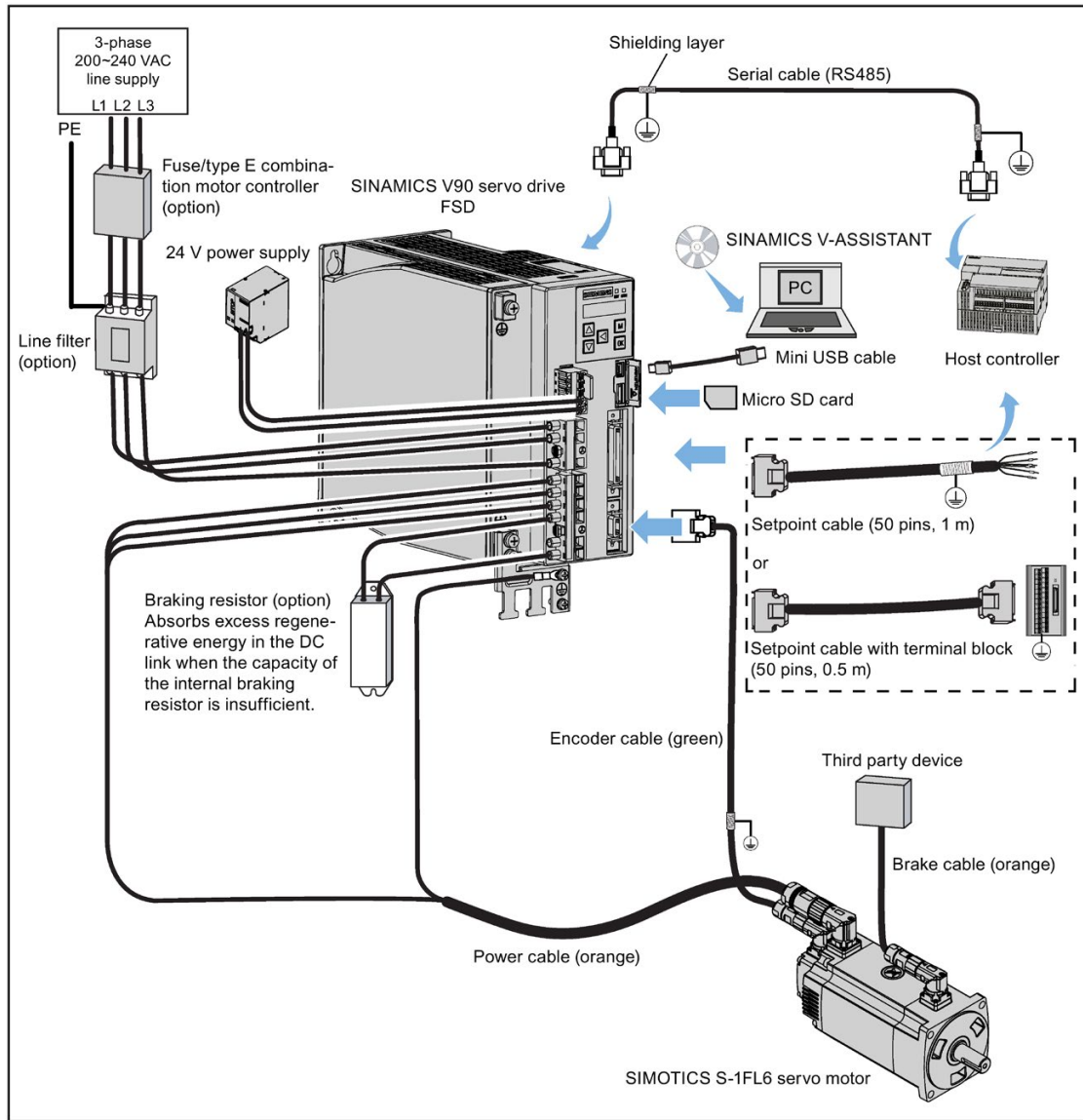

### SINAMICS V90 400 V variant

The configuration for FSA when used on the three phase power network:

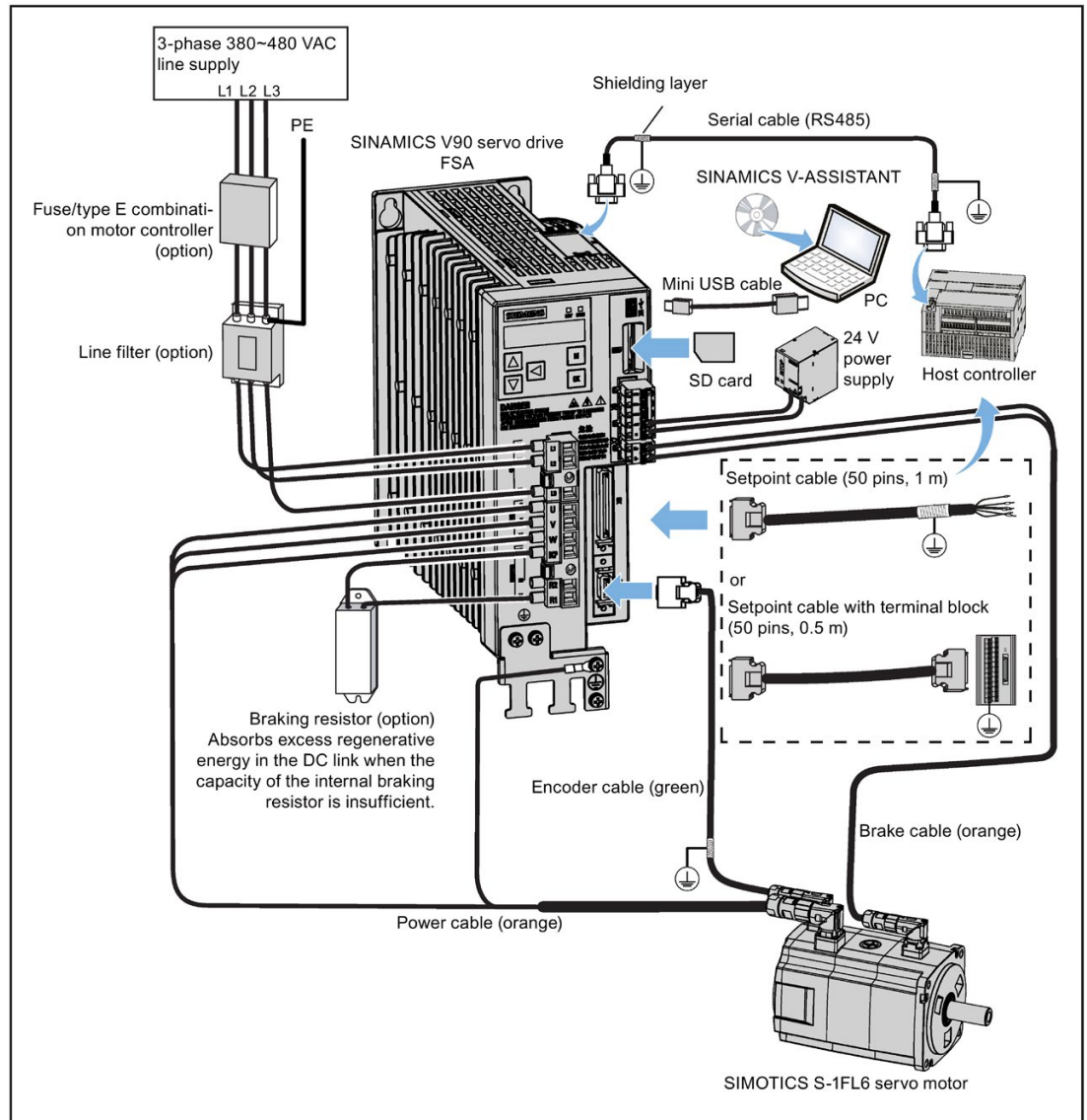

### CAUTION











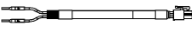

#### Personal injury and damage to property from inadequate protection

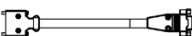
Inadequate protection may cause minor personal injury or damage to property.





- Route a second PE conductor with the cross section of the supply system lead in parallel to the protective earth via separate terminals or use a copper protective earth conductor with a cross section of 10 mm<sup>2</sup>.
- Terminals for equipotential bondings that exist in addition to terminals for PE conductors must not be used for looping-through the PE conductors.
- To ensure protective separation, an isolating transformer must be used for the 200 VAC/380 VAC line supply system.

## 2.5 Accessories

### 2.5.1 MOTION-CONNECT 300 cables and connectors

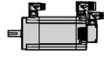
Cable connectors (drive side)		MOTION-CONNECT 300 cables				Cable connectors (motor side)	
Type	Article No. 6FX2003 -	Type	Article No. 6FX3002- .....	Illustration (left: drive side; right: motor side)	Used for (SIMOTICS S-1FL6)	Type	Article No. 6FX2003 -
-	-	Power cable	5CK01- .....		Low inertia:  0.05 kW to 1 kW	Power connector	0LL12
-	-	Brake cable	5BK02- .....			Brake connector	0LL52
Encoder connector	0SB14	Incremental encoder cable	2CT20- .....			Incremental encoder connector	0SL12
		Absolute encoder cable	2DB20- .....			Absolute encoder connector	0DB12
-	-	Power cable	5CK31- .....	For low inertia motors of 1.5 kW to 2 kW: 	Low inertia (with straight connectors):  1.5 kW to 2 kW  High inertia (with straight connectors):  0.4 kW to 7 kW	Power connector	0LL11
			5CL01- .....	For high inertia motors of 0.4 kW to 1 kW: 			
			5CL11- .....	For high inertia motors of 1.5 kW to 7 kW: 			
-	-	Brake cable	5BL02- .....			Brake connector	0LL51
Encoder connector	0SB14	Incremental encoder cable	2CT10- .....			Incremental encoder connector	0SL11
		Absolute encoder cable	2DB10- .....			Absolute encoder connector	0DB11

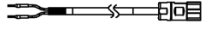
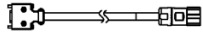
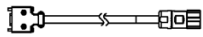

Cable connectors (drive side)		MOTION-CONNECT 300 cables				Cable connectors (motor side)		
Type	Article No. 6FX2003 -	Type	Article No. 6FX3002-		Illustration (left: drive side; right: motor side)	Used for (SIMOTICS S-1FL6)	Type	Article No. 6FX2003 -
-	-	Power cable	5CK32-	....	For low inertia motors of 1.5 kW to 2 kW: 	Low inertia (with straight connectors):  1.5 kW to 2 kW	Power connector	0LL13
			5CL02-	....	For high inertia motors of 0.4 kW to 1 kW: 			
			5CL12-	....	For high inertia motors of 1.5 kW to 7 kW: 			
-	-	Brake cable	5BL03-	....			Brake connector	0LL53
Encoder connector	0SB14	Incremental encoder cable	2CT12-	....			Incremental encoder connector	0SL13
			Absolute encoder cable	2DB12-	....	For low inertia motors of 1.5 kW to 2 kW 		Absolute encoder connector
		2DB10-		....	For high inertia motors of 0.4 kW to 7 kW 		Absolute encoder connector	0DB11
<b>Cable length <sup>1)</sup></b>								
3 m			1AD0		<sup>1)</sup> Cables with a maximum length of 20 m are provided at delivery. You can also make your own cables with a maximum length of 30 m, which are not tested by Siemens. <sup>2)</sup> Cables with lengths of 7 m and 15 m are only supplied for high inertia motors.			
5 m			1AF0					
7 m <sup>2)</sup>			1AH0					
10 m			1BA0					
15 m <sup>2)</sup>			1BF0					
20 m			1CA0					

For more information about how to assemble cable connectors on both the drive and motor sides, see Sections "Assembly of cable terminals on the drive side (Page 373)" and "Assembly of cable connectors on the motor side (Page 376)".

### 2.5.2 Setpoint cables and connectors

The cable is used to connect the drive to a controller

Name	Article number	Length (m)
<b>Option 1</b>		
Setpoint connector (50 pins)	6SL3260-2NA00-0VA0	-
Setpoint cable (50 pins)	6SL3260-4NA00-1VB0	1
<b>Option 2</b>		
Setpoint cable with terminal block (50 pins) <sup>1)</sup>	6SL3260-4NA00-1VA5	0.5





1) Make sure that you connect a terminal block according to the pin definitions of interface X8 on the existing SINAMICS V90 servo drive.

The wire color of the setpoint cable exposed side and X8 pin definitions, see Section “Control/status interface - X8 (Page 103)”.

### 2.5.3 Connectors used on the drive front panel

If you need a new connector that used on the drive front panel, you can order a connector kit from Siemens.

#### Connector kits

Illustration	Used for (SINAMICS servo drive)	Article number
<b>200 V variant</b>		
	FSA, FSB	6SL3200-0WT02-0AA0
	FSC, FSD	6SL3200-0WT03-0AA0
<b>400 V variant</b>		
	FSAA	6SL3200-0WT00-0AA0
	FSA	6SL3200-0WT01-0AA0

1) You can obtain the connectors for SINAMICS V90 400V servo drives of FSB and FSC from the connector kits for SINAMICS V90 400V servo drives of FSAA or FSA.



## 2.5.4 External 24 VDC power supply

A 24 VDC power supply is needed to supply the V90 servo drive. Refer to the table below to select the power supply:

Parameter	Description
Rated voltage (V)	24 (-15% to +20%) <sup>1)</sup>
Maximum current (A)	When using a motor without a brake: 1.6 A When using a motor with a brake: 1.6 A + motor holding brake rated current (See Section "Technical data - servo motors (Page 61)")
Ripple caused by the rectifier	≤ 5%
Safety insulation class	PELV

<sup>1)</sup> When using a motor with a brake, the minimum voltage of 24 VDC -10% must be available at the connector on the motor side in order to guarantee that the brake reliably opens. If the maximum voltage of 24 VDC +10% is exceeded, then the brake could re-close. The voltage drop along the brake feeder cable must be taken into consideration. The voltage drop  $\Delta U$  for copper cables can be approximately calculated as follows:

$$\Delta U [V] = 0.042 \Omega \cdot \text{mm}^2/\text{m} \cdot (l/q) \cdot I_{\text{Brake}}$$

Where:  $l$  = Cable length [m],  $q$  = Brake cable cross section [ $\text{mm}^2$ ],  $I_{\text{Brake}}$  = DC current of brake [A]

---

### Note

Make sure that you use different 24 V power supplies for the drive and for the inductive loads such as relays or solenoid valves; otherwise, the drive may not work properly.

---

### Note

The max. length of the cable used to connect the 24 V power supply to the drive is 10 m.

---

### 2.5.5 Fuse/Type-E combination motor controller

A fuse/Type-E combination motor controller can be used to protect the system. Integral solid state short circuit protection does not provide branch circuit protection. Branch circuit protection must be provided in accordance with the National Electrical Code and any additional local codes. Refer to the table below for the selection of fuses and Type-E motor controllers:

#### 200 V variant

SINAMICS V90		Recommended fuse		Type-E combination motor controller <sup>1)</sup>			
Frame size	Rated power (kW)	CE-compliant	UL/cUL-compliant listed (JDDZ) fuse	Rated current (A)	Rated voltage (VAC)	Rated power (hp)	Article number 3RV 2011-
<b>1-phase, 200 VAC to 240 VAC</b>							
FSA	0.1	3NA3 801 (6 A)	6 A	2.8 to 4	230/240	1/3	1EA10
	0.2	3NA3 801 (6 A)	6 A	2.8 to 4	230/240	1/3	1EA10
FSB	0.4	3NA3 803 (10 A)	10 A	5.5 to 8	230/240	1	1HA10
FSC	0.75	3NA3 805 (16 A)	20 A	9 to 12.5	230/240	2	1KA10
<b>3-phase, 200 VAC to 240 VAC</b>							
FSA	0.1	3NA3 801 (6 A)	6 A	2.8 to 4	230/240	3/4	1EA10
	0.2	3NA3 801 (6 A)	6 A	2.8 to 4	230/240	3/4	1EA10
FSB	0.4	3NA3 803 (10 A)	10 A	2.8 to 4	230/240	3/4	1EA10
FSC	0.75	3NA3 805 (16 A)	20 A	5.5 to 8	230/240	2	1HA10
FSD	1.0	3NA3 805 (16 A)	20 A	7 to 10	230/240	3	1JA10
	1.5	3NA3 810 (25 A)	25 A	10 to 16	230/240	5	4AA10
	2.0	3NA3 810 (25 A)	25 A	10 to 16	230/240	5	4AA10

<sup>1)</sup> The above types for Type-E combination motor controllers are listed in compliance with both CE and UL/cUL standards.

#### 400 V variant

SINAMICS V90		Recommended fuse type		Type-E combination motor controller <sup>1)</sup>			
Frame size	Rated power (kW)	CE-compliant	UL/cUL-compliant listed (JDDZ) fuse	Rated current (A)	Rated voltage (VAC)	Rated power (hp)	Article number 3RV 2021-
<b>3-phase, 380 VAC to 480 VAC</b>							
FSA	0.4	3NA3 801 (6 A)	10 A	2.2 to 3.2	380/480	0.5	1DA10
FSA	0.75	3NA3 801 (6 A)	10 A	2.8 to 4	380/480	1	1EA10
	1.0	3NA3 803 (10 A)	10 A	3.5 to 5	380/480	1.34	1FA10
FSB	1.5	3NA3 803 (10 A)	15 A	5.5 to 8	380/480	2	1HA10
	2.0	3NA3 805 (16 A)	15 A	11 to 16	380/480	2.68	4AA10
FSC	3.5	3NA3 807 (20 A)	25 A	14 to 20	380/480	4.7	4BA10
	5.0	3NA3 807 (20 A)	25 A	14 to 20	380/480	6.7	4BA10
	7.0	3NA3 810 (25 A)	25 A	20 to 25	380/480	9.4	4DA10

<sup>1)</sup> The above types for Type-E combination motor controllers are listed in compliance with both CE and UL/cUL standards.

**⚠ WARNING****Requirements for United States/Canadian installations (UL/cUL)**

Suitable for use on a circuit capable of delivering not more than 65000 rms Symmetrical Amperes, 480 VAC maximum for 400 V variants of drives or 240 VAC maximum for 200 V variant drives, when protected by the UL/cUL listed (JDDZ) fuse or type-E combination motor controller. For each frame size AA, A, B, C and D, use 75 °C copper wire only.

This equipment is capable of providing internal motor overload protection according to UL508C.

For Canadian (cUL) installations the drive mains supply must be fitted with any external recommended suppressor with the following features:

- Surge-protective devices; device shall be a Listed Surge-protective device (Category code VZCA and VZCA7)
- Rated nominal voltage 480/277 VAC, 50/60 Hz, 3-phase; 120/208 VAC, 50/60 Hz, 1/3-phase
- Clamping voltage VPR = 2000 V, IN = 3kA min, MCOV = 508 VAC, SCCR = 65 kA
- Suitable for Type 2 SPD application
- Clamping shall be provided between phases and also between phase and ground

## 2.5.6 Braking resistor

The SINAMICS V90 has a built-in braking resistor. The table below shows the information of the built-in resistor:

SINAMICS V90	Resistance ( $\Omega$ )	Max. power (kW)	Rated power (W)	Max. energy (kJ)
<b>1/3-phase, 200 VAC to 240 VAC</b>				
FSA (0.2 kW)	150	1.09	13.5	0.55
FSB	100	1.64	20.5	0.82
FSC	50	3.28	41	1.64
<b>3-phase, 200 VAC to 240 VAC</b>				
FSD (1 kW)	50	3.28	41	1.64
FSD (1.5 kW to 2 kW)	25	6.56	82	3.28
<b>3-phase, 380 VAC to 480 VAC</b>				
FSAA	533	1.2	17	1.8
FSA	160	4	57	6
FSB	70	9.1	131	13.7
FSC	27	23.7	339	35.6

**Note**

The 200 V variant servo drive with rated power of 0.1 kW (FSA) does not have a built-in resistor.

2.5 Accessories

When the motor works in a fast round-trip process, the voltage of the line supply increases. The braking resistor starts to work if the voltage reaches the set threshold. The temperature of the heat sink increases (>100 °C) when the braking resistor is working. If alarms A52901 and A5000 appear at the same time, you need to switch the built-in braking resistor to the external braking resistor. You can select a standard braking resistor according to the table below:

SINAMICS V90	Minimum re-sistance (Ω)	Max. power (kW)	Rated power (W)	Max. energy (kJ)
<b>1/3-phase, 200 VAC to 240 VAC</b>				
FSA	150	1.09	20	0.8
FSB	100	1.64	21	1.23
FSC	50	3.28	62	2.46
<b>3-phase, 200VAC to 240 VAC</b>				
FSD (1 kW)	50	3.28	62	2.46
FSD (1.5 kW to 2 kW)	25	6.56	123	4.92
<b>3-phase, 380 VAC to 480 VAC</b>				
FSA	533	1.2	30	2.4
FSA	160	4	100	8
FSB	70	9.1	229	18.3
FSC	27	23.7	1185	189.6

**Note**

When selecting a braking resistor, you must take into account the factors such as braking inertia, deceleration time, speed variation, and braking period according to your specific application and technology. The resistance of the selected braking resistor must not be lower than the minimum resistance listed above.

**2.5.7 Line filter**

Siemens recommends you to use a line filter to protect the system from high frequency noise. The line filter restricts the conductive interference emitted from the SINAMICS V90 to the permissible values. The SINAMICS V90 drives with these external line filters have been tested in accordance with the emission requirements of the Category C2 environment. The conductive emissions and radiated emissions are in compliance with the Class A requirements of the EN 55011 standard.

**Recommended line filters**

SINAMICS V90	Rated current (A)	Article number	Degree of protection
<b>1-phase, 200 VAC to 240 VAC</b>			
FSA	18	6SL3203-0BB21-8VA0	IP20
FSB			
FSC			

SINAMICS V90	Rated current (A)	Article number	Degree of protection
<b>3-phase, 200 VAC to 240 VAC</b>			
FSA	5	6SL3203-0BE15-0VA0	IP20
FSB			
FSC			
FSD	12	6SL3203-0BE21-2VA0	
<b>3-phase, 380 VAC to 480 VAC</b>			
FSAA	5	6SL3203-0BE15-0VA0	IP20
FSA			
FSB	12	6SL3203-0BE21-2VA0	
FSC	20	6SL3203-0BE22-0VA0	

**Outline dimensions (mm)**

**Filter used on the single phase power network**

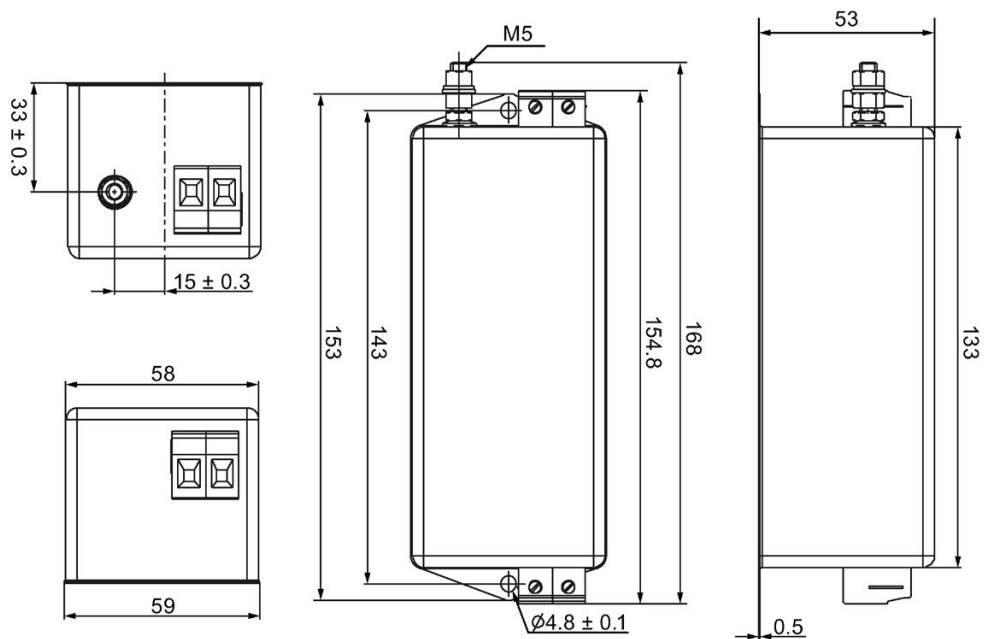

18 A

Filter used on the three phase power network

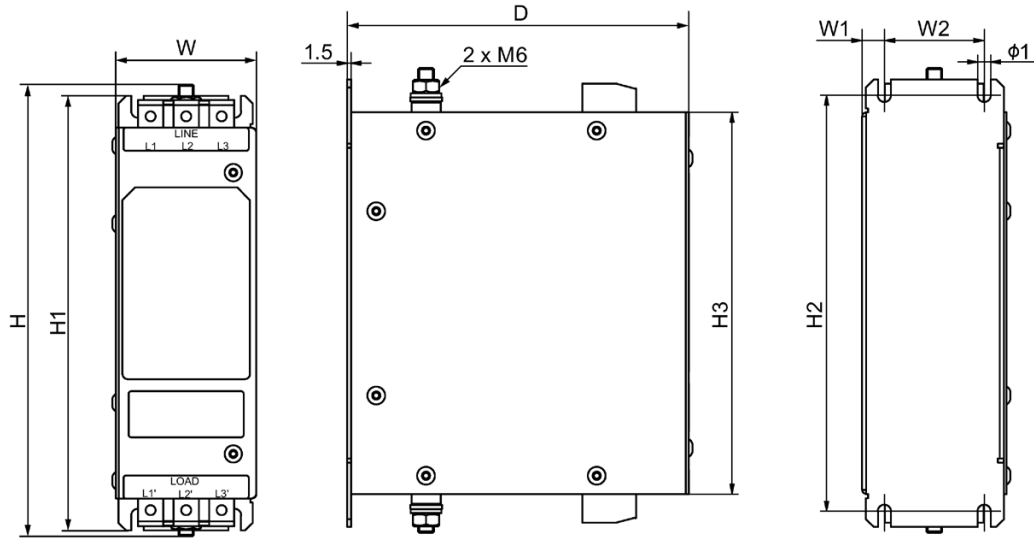

Rated current (A)	W	W1	W2	H	H1	H2	H3	D	ø1
5	55	8.5	38	176.7	170	158	145	130	5
12	75	8.5	58	176.7	170	158	145	140	5
20	60	10	40	251.7	250	240	220	130	5.5

Basic technical data

Parameter	Description		
<b>Filter used on the single phase power network</b>			
Rated current	18 A		
Rated voltage	Single phase 200 VAC to 240 VAC (-15% to +10%)		
Line frequency	50/60 Hz (-10% to +10%)		
Product standard	IEC 61800-5-1		
Power loss	< 1.2 W		
Weight	0.9 kg		
Package size (H × W × D)	230 mm × 95 mm × 90 mm		
<b>Filter used on the three phase power network</b>			
Rated current	5 A	12 A	20 A
Rated voltage	Three phase 200 VAC to 480 VAC (-15% to +15%)		Three phase 380 VAC to 480 VAC (-15% to +15%)
Line frequency	50/60 Hz (-10% to +10%)		
Product standard	IEC 61800-5-1		
Power loss	< 2 W	< 3 W	< 7 W
Weight	0.68 kg	1.01 kg	1.33 kg
Package size (H × W × D)	140 mm × 200 mm × 260 mm		140 mm × 200 mm × 330 mm

## Insertion loss

Parameter	Description					
<b>Rated current</b>	<b>5 A</b>					
Noise frequency (MHz)	0.15	0.5	1.0	5.0	10	30
CM (dB)	50	80	70	45	35	20
DM (dB)	50	75	65	55	55	40
<b>Rated current</b>	<b>12 A</b>					
Noise frequency (MHz)	0.15	0.5	1.0	5.0	10	30
CM (dB)	65	80	75	45	35	20
DM (dB)	60	70	70	60	50	30
<b>Rated current</b>	<b>18 A</b>					
Noise frequency (MHz)	0.15	0.5	1.0	5.0	10	30
CM (dB)	32	70	82	88	81	90
DM (dB)	40	67	68	72	69	59
<b>Rated current</b>	<b>20 A</b>					
Noise frequency (MHz)	0.15	0.5	1.0	5.0	10	30
CM (dB)	60	70	65	45	35	20
DM (dB)	55	65	60	50	45	40

Connecting (example)

Filter used on the single phase power network

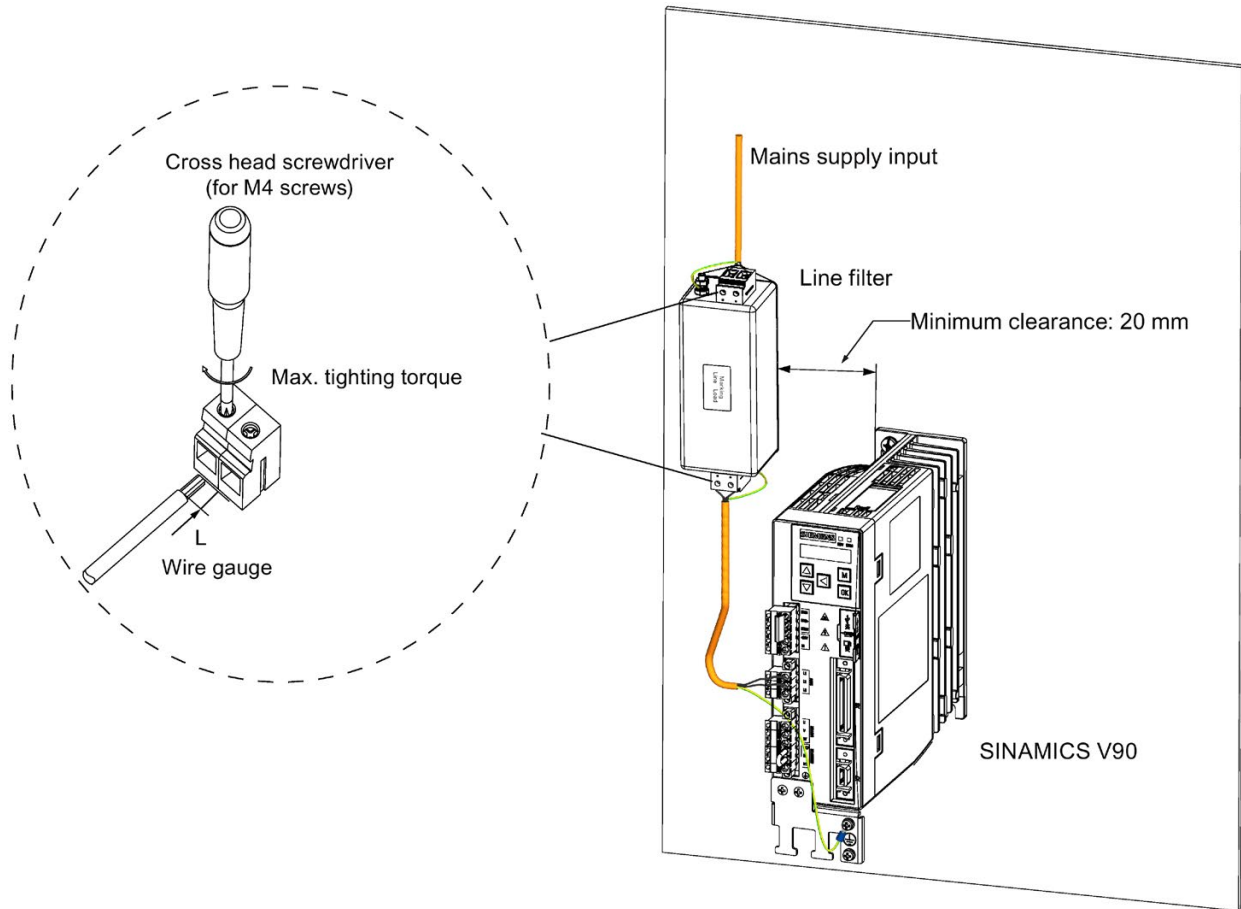

SINAMICS V90	Rated current (A)	Max. tightening torque (Nm)	Wire gauge (AWG)	Stripping length L (mm)
<b>200 V variant (6SL3210-5FB...-....)</b>				
10-1UA2	18	1.5	14 to 12	8
10-2UA2				
10-4UA1			18 to 16	
10-8UA0			14 to 12	



Filter used on the three phase power network

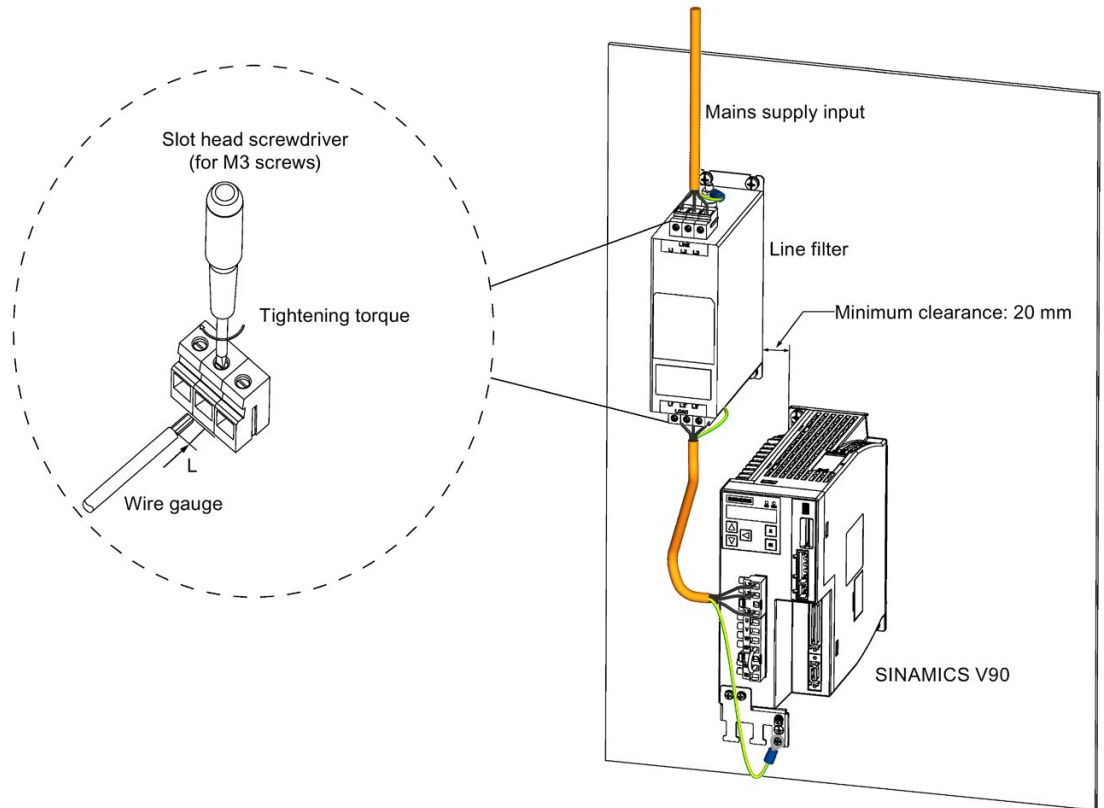

SINAMICS V90	Rated current (A)	Tightening torque (Nm)	Wire gauge (AWG)	Stripping length L (mm)	
<b>200 V variant (6SL3210-5FB...-....)</b>					
10-1UA2	5	0.7 to 0.8	14 to 12	8	
10-2UA2					
10-4UA1			22 to 20		
10-8UA0			18 to 16		
11-0UA1	12	0.7 to 0.8	16 to 14		
11-5UA0			14 to 12		
12-0UA0					
<b>400 V variant (6SL3210-5FE...-....)</b>					
10-4UA0	5	0.7 to 0.8	15 to 13	8	
10-8UA0					
11-0UA0					
11-5UA0	12	0.7 to 0.8	15 to 14		
12-0UA0					
13-5UA0	20	0.7 to 0.8	11 to 10		
15-0UA0					
17-0UA0					

### 2.5.8 Micro SD card/SD card

Optionally you can use a micro SD card/SD card to copy drive parameters or perform a firmware update. Micro SD card is used for the 200 V variant servo drive and SD card is used for the 400 V variant servo drive. Siemens recommends you to use the Siemens SD card (article number: 6SL3054-4AG00-2AA0).

- For the servo drives with firmware version V1.04.00 or higher, you can select high quality micro SD cards/SD cards with a maximum capacity of 32 GB from manufacturers such as Kingston or SanDisk.
- For the servo drives with earlier firmware version, you can select high quality micro SD cards/SD cards with a maximum capacity of 2 GB from manufacturers such as KINGMAX, Kingston or SanDisk.

### 2.5.9 Replacement fans

The table below lists the replacement fans for SINAMICS V90 servo drives.

SINAMICS V90	Article number
<b>3-phase, 200 VAC to 240 VAC</b>	
FSD	6SL3200-0WF00-0AA0
<b>3-phase, 380 VAC to 480 VAC</b>	
FSB	6SL3200-0WF00-0AA0
FSC	6SL3200-0WF01-0AA0

## 2.6 Function list

Function	Description	Control mode
Pulse train input position control (PTI) (Page 192)	Implements accurate positioning through two pulse train input channels: 5 V differential or 24 V single end signal. In addition, it supports the S-curve position smoothing function	PTI
Internal position control (IPos) (Page 206)	Implements accurate positioning through internal position commands (up to eight groups) and allows to specify the acceleration/speed for positioning	IPos
Speed control (S) (Page 226)	Flexibly controls motor speed and direction through external analog speed commands (0 - ±10 VDC) or internal speed commands (up to seven groups)	S
Torque control (T) (Page 232)	Flexibly controls motor output torque through external analog torque commands (0 - ±10 VDC) or internal torque commands. In addition, it supports speed limit function to prevent overspeed when a motor has no loads	T
Compound controls (Page 181)	Supports flexible switches among position control mode, speed control mode, and torque control mode	PTI/S, IPos/S, PTI/T, IPos/T, S/T



Function	Description	Control mode
Absolute position system (Page 261)	Allows to implement motion control tasks immediately after the servo system with an absolute encoder is powered on, needless of carrying out referencing or zero position operation beforehand	PTI
Gain switching (Page 301)	Switches between gains during motor rotation or stop with an external signal or internal parameters to reduce noise and positioning time, or improve the operation stability of a servo system	PTI, IPos, S
PI/P switching (Page 305)	Switches from PI control to P control with an external signal or internal parameters to suppress overshooting during acceleration or deceleration (for speed control mode) or to suppress undershooting during positioning and reduce the settling time (for position control mode)	PTI, IPos, S
Safe Torque Off (STO) (Page 280)	Safely disconnects torque-generating motor power supply to prevent an unintentional motor restart	PTI, IPos, S, T
Zero speed clamp (Page 229)	Stops motor and clamps the motor shaft when motor speed setpoint is below a parameterized threshold level	S
Cyclic communication (Page 242)	Supports the communication between the SINAMICS V90 servo drive and PLC with the standard Modbus communication protocol	PTI, IPos, S, T
One-button auto tuning (Page 287)	Estimates the machine characteristic and sets the closed loop control parameters (position loop gain, speed loop gain, speed integral compensation, filter if necessary, etc.) without any user intervention	PTI, IPos, S, T
Real-time auto tuning (Page 292)	Estimates the machine characteristic and sets the closed loop control parameters (position loop gain, speed loop gain, speed integral compensation, filter if necessary, etc.) continuously in real time without any user intervention	PTI, IPos, S, T
Resonance suppression (Page 297)	Suppresses the mechanical resonance, such as workpiece vibration and base shake	PTI, IPos, S, T
Low frequency vibration suppression (Page 300)	Suppresses the low frequency vibration in the machine system	IPos
Speed limit (Page 199)	Limits motor speed through external analog speed limit commands (0 - $\pm 10$ VDC) or internal speed limit commands (up to three groups)	PTI, IPos, S, T
Torque limit (Page 200)	Limits motor torque through external analog torque limit commands (0 - $\pm 10$ VDC) or internal torque limit commands (up to three groups)	PTI, IPos, S
Electronic gear ratio (Page 195)	Defines a multiplier factor for input pulses	PTI, IPos
Basic operator panel (BOP) (Page 162)	Displays servo status on a 6-digit 7-segment display	PTI, IPos, S, T
External braking resistor - DCP, R1 (Page 144)	An external braking resistor can be used when the internal braking resistor is insufficient for regenerative energy	PTI, IPos, S, T
Digital inputs/outputs (DIs/DOs) (Page 106)	Control signals and status signals can be assigned to eight programmable digital inputs and six digital outputs	PTI, IPos, S, T
Smoothing function (Page 194)	Transforms position characteristics from the pulse train input setpoint into an S-curve profile with a parameterized time constant	PTI
SINAMICS V-ASSISTANT	You can perform parameter settings, test operation, adjustment and other operations with a PC	PTI, IPos, S, T

## 2.7 Technical data

### 2.7.1 Technical data - servo drives

#### 2.7.1.1 SINAMICS V90 200 V variant

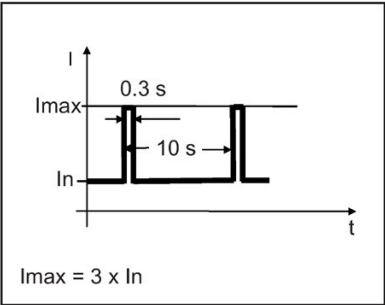
#### General technical data

Parameter	Description
Overload capability	300%  <p><math>I_{max} = 3 \times I_n</math></p>
Control system	Servo control
Dynamic brake	Built-in
Protective functions	Earthing fault protection, output short-circuit protection <sup>1)</sup> , overvoltage/undervoltage protection <sup>2)</sup> , I <sup>2</sup> t inverter, I <sup>2</sup> t motor, IGBT overtemperature protection <sup>3)</sup>
Overvoltage criteria	Category III
Certification	
Speed control mode	
Speed control range	Analog speed command 1:2000, internal speed command 1:5000
Analog speed command input	-10 VDC to +10 VDC/rated speed
Torque limit	Set through a parameter or the analog input command (0 VDC to +10 VDC/max. torque)
Position control mode	
Max. input pulse frequency	1 M (differential input), 200 kpps (open collector input)
Command pulse multiplying factor	Electronic gear ratio (A/B) A: 1 - 10000, B: 1 - 10000 $1/50 < A/B < 200$
In-position range setting	0 to ±10000 pulse (command pulse unit)
Error excessive	±1/10 revolutions
Torque limit	Set through a parameter or the analog input command (0 VDC to +10 VDC/max. torque)

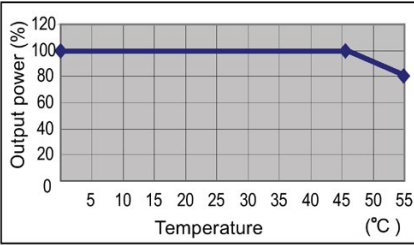
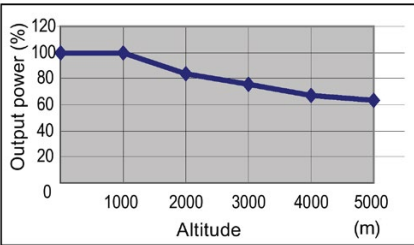
Parameter		Description
Torque control mode		
Analog torque command input		-10 VDC to +10 VDC/max. torque (input impedance 10 kΩ to 12 kΩ)
Speed limit		Set through a parameter or the analog input command (0 VDC to +10 VDC/max. rated speed)
Environmental conditions		
Surrounding air temperature	Operation	0 °C to 45 °C: without power derating 45 °C to 55 °C: with power derating  
	Storage	-40 °C to +70 °C
Ambient humidity	Operation	< 90% (non-condensing)
	Storage	90% (non-condensing)
Operating environment		Indoors (without direct sunlight), free from corrosive gas, combustible gas, oil gas, or dust
Altitude		≤ 1000 m (without power derating)  
Degree of protection		IP 20
Degree of pollution		Class 2
Vibration		
Operation	Shock	Operational area II Peak acceleration: 5 g, 30 ms and 15 g, 11 ms Quantity of shocks: 3 per direction × 6 directions Duration of shock: 1 s
	Vibration	Operational area II 10 Hz to 58 Hz: 0.075 mm deflection 58 Hz to 200 Hz: 1 g vibration
Product packaging	Vibration	2 Hz to 9 Hz: 3.5 mm deflection 9 Hz to 200 Hz: 1 g vibration Quantity of cycles: 10 per axis Sweep seed: 1 octave/min

2.7 Technical data

- 1) Integral solid state short circuit protection does not provide branch circuit protection. Branch circuit protection must be provided in accordance with the National Electrical Code and any additional local codes.
- 2) The V90 200 V servo drive has an overvoltage threshold of 410 VDC and an undervoltage threshold of 150 VDC; the V90 400 V servo drive has an overvoltage threshold of 820 VDC and an undervoltage threshold of 320 VDC.
- 3) SINAMICS V90 does not support motor overtemperature protection. Motor overtemperature is calculated by  $I^2t$  and protected by the output current from the drive.

Specific technical data

Order No. 6SL3210-5FB...	10-1UA2	10-2UA2	10-4UA1	10-8UA0	11-0UA1	11-5UA0	12-0UA0	
Frame size	FSA	FSA	FSB	FSC	FSD	FSD	FSD	
Rated output current (A)	1.2	1.4	2.6	4.7	6.3	10.6	11.6	
Max. output current (A)	3.6	4.2	7.8	14.1	18.9	31.8	34.8	
Max. supported motor power (kW)	0.1	0.2	0.4	0.75	1.0	1.5	2	
Output frequency (Hz)	0 to 330							
Cooling method	Self-cooled				Fan-cooled			
Outline dimensions (W x H x D, mm)	45 x 170 x 170		55 x 170 x 170	80 x 170 x 195	95 x 170 x 195			
Weight (kg)	1.1		1.3	1.95	2.35	2.4		
Power loss <sup>1)</sup>								
Main circuit (W)	8	15	33	48	65	105	113	
Regenerative resistor (W)	5	5	7	9	13	25	25	
Control circuit (W)	16	16	16	16	16	18	18	
Total (W)	29	36	56	73	94	148	156	
Mains power supply								
Voltage/frequency	FSA, FSB and FSC: single phase/three phase 200 VAC to 240 VAC, 50/60 Hz FSD: three phase 200 VAC to 240 VAC, 50/60 Hz							
Permissible voltage fluctuation	-15% to +10%							
Permissible frequency fluctuation	-10% to +10%							
Permissible supply configuration	TN, TT, IT							
Short-circuit current (SCCR)	Maximum permissible short-circuit current: 65 kA rms Minimum required short-circuit current: 5 kA rms							
Rated input current (A)	1-phase	2.5	3.0	5.0	10.4	-	-	-
	3-phase	1.5	1.8	3.0	5.0	7.0	11.0	12.0
Power supply capacity (kVA)	1-phase	0.5	0.7	1.2	2.0	-	-	-
	3-phase	0.5	0.7	1.1	1.9	2.7	4.2	4.6
Inrush current (A)	8.0							



Order No. 6SL3210-5FB...	10-1UA2	10-2UA2	10-4UA1	10-8UA0	11-0UA1	11-5UA0	12-0UA0
Frame size	FSA	FSA	FSB	FSC	FSD	FSD	FSD
24 VDC power supply							
Voltage (V)	24 (-15% to +20%) <sup>2)</sup>						
Maximum current (A)	When using a motor without a brake: 1.6 A When using a motor with a brake: 1.6 A + motor holding brake rated current (See Section "Technical data - servo motors (Page 61)".)						
Ripple caused by the rectifier	≤ 5%						
Safety insulation class	PELV						

1) The values here are calculated at rated load.

2) When SINAMICS V90 works with a motor with a brake, the voltage tolerance of 24 VDC power supply must be -10% to +10% to meet the voltage requirement of the brake.

### 2.7.1.2 SINAMICS V90 400 V variant

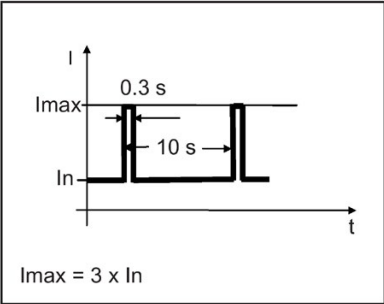
#### General technical data

Parameter	Description
Overload capability	300%  $I_{max} = 3 \times I_n$
Control system	Servo control
Dynamic brake	Built-in
Protective functions	Earthing fault protection, output short-circuit protection <sup>1)</sup> , overvoltage/undervoltage protection <sup>2)</sup> , I <sup>2</sup> t inverter, I <sup>2</sup> t motor, IGBT overtemperature protection <sup>3)</sup>
Overvoltage criteria	Category III
Certification	
Speed control mode	
Speed control range	Analog speed command 1:2000, internal speed command 1:5000
Analog speed command input	-10 VDC to +10 VDC/rated speed
Torque limit	Set through a parameter or the analog input command (0 VDC to +10 VDC/max. torque)

General information

2.7 Technical data

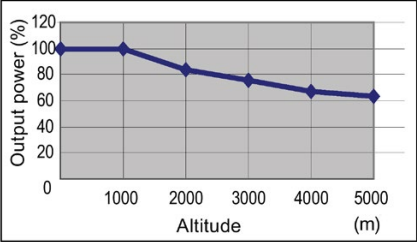
Parameter	Description															
Position control mode																
Max. input pulse frequency	1 M (differential input), 200 kpps (open collector input)															
Command pulse multiplying factor	Electronic gear ratio (A/B) A: 1 - 10000, B: 1 - 10000 $1/50 < A/B < 200$															
In-position range setting	0 to $\pm 10000$ pulse (command pulse unit)															
Error excessive	$\pm 1/10$ revolutions															
Torque limit	Set through a parameter or the analog input command (0 VDC to +10 VDC/max. torque)															
Torque control mode																
Analog torque command input	-10 VDC to +10 VDC/max. torque (input impedance 10 k $\Omega$ to 12 k $\Omega$ )															
Speed limit	Set through a parameter or the analog input command (0 VDC to +10 VDC/max. rated speed)															
Environmental conditions																
Surrounding air temperature	Operation	0 °C to 45 °C: without power derating 45 °C to 55 °C: with power derating														
	Storage	-40 °C to +70 °C														
Ambient humidity	Operation	< 90% (non-condensing)														
	Storage	90% (non-condensing)														
Operating environment	Indoors (without direct sunlight), free from corrosive gas, combustible gas, oil gas, or dust															
Altitude	$\leq 1000$ m (without power derating)															
	 <table border="1"> <caption>Output power (%) vs Altitude (m)</caption> <thead> <tr> <th>Altitude (m)</th> <th>Output power (%)</th> </tr> </thead> <tbody> <tr> <td>0</td> <td>100</td> </tr> <tr> <td>1000</td> <td>100</td> </tr> <tr> <td>2000</td> <td>85</td> </tr> <tr> <td>3000</td> <td>75</td> </tr> <tr> <td>4000</td> <td>65</td> </tr> <tr> <td>5000</td> <td>60</td> </tr> </tbody> </table>		Altitude (m)	Output power (%)	0	100	1000	100	2000	85	3000	75	4000	65	5000	60
Altitude (m)	Output power (%)															
0	100															
1000	100															
2000	85															
3000	75															
4000	65															
5000	60															
Degree of protection	IP 20															
Degree of pollution	Class 2															



Parameter		Description
Vibration		
Operation	Shock	Operational area II Peak acceleration: 5 g, 30 ms and 15 g, 11 ms Quantity of shocks: 3 per direction × 6 directions Duration of shock: 1 s
	Vibration	Operational area II 10 Hz to 58 Hz: 0.075 mm deflection 58 Hz to 200 Hz: 1 g vibration
Product packaging	Vibration	2 Hz to 9 Hz: 3.5 mm deflection 9 Hz to 200 Hz: 1 g vibration Quantity of cycles: 10 per axis Sweep seed: 1 octave/min

- 1) Integral solid state short circuit protection does not provide branch circuit protection. Branch circuit protection must be provided in accordance with the National Electrical Code and any additional local codes.
- 2) The V90 200 V servo drive has an overvoltage threshold of 410 VDC and an undervoltage threshold of 150 VDC; the V90 400 V servo drive has an overvoltage threshold of 820 VDC and an undervoltage threshold of 320 VDC.
- 3) SINAMICS V90 does not support motor overtemperature protection. Motor overtemperature is calculated by  $I^2t$  and protected by the output current from the drive.

### Specific technical data

Order No. 6SL3210-5FE...	10-4UA0	10- 8UA0	11-0UA0	11-5UA0	12- 0UA0	13-5UA0	15-0UA0	17-0UA0
Frame size	FSAA	FSA	FSA	FSB	FSB	FSC	FSC	FSC
Rated output current (A)	1.2	2.1	3.0	5.3	7.8	11.0	12.6	13.2
Max. output current (A)	3.6	6.3	9.0	13.8	23.4	33.0	37.8	39.6
Max. supported motor power (kW)	0.4	0.75	1.0	1.75	2.5	3.5	5.0	7.0
Output frequency (Hz)	0 to 330							
Cooling method	Self-cooled			Fan-cooled				
Outline dimensions (W x H x D, mm)	60 x 180 x 200	80 x 180 x 200		100 x 180 x 220		140 x 260 x 240		
Weight (kg)	1.800	2.500	2.510	3.055	3.130	6.515	6.615	6.615
Power loss <sup>1)</sup>								
Main circuit (W)	12	29	32	84	96	92	115	138
Regenerative resistor (W)	17	57	57	131	131	339	339	339
Control circuit (W)	32	32	35	35	35	36	36	36
Total (W)	61	118	124	250	262	467	490	513
Power supply								
Voltage/frequency	3-phase 380 VAC to 480 VAC, 50/60 Hz							
Permissible voltage fluctuation	-15% to +10%							
Permissible frequency fluctuation	-10% to +10%							

General information

2.7 Technical data



Order No. 6SL3210-5FE...	10-4UA0	10- 8UA0	11-0UA0	11-5UA0	12- 0UA0	13-5UA0	15-0UA0	17-0UA0
Frame size	FSAA	FSA	FSA	FSB	FSB	FSC	FSC	FSC
Permissible supply configuration	TN, TT, IT							
Short-circuit current (SCCR)	Maximum permissible short-circuit current: 65 kA rms Minimum required short-circuit current: 5 kA rms							
Rated input current (A)	1.5	2.6	3.8	6.6	9.8	13.8	15.8	16.5
Power supply capacity (kVA)	1.7	3.0	4.3	7.6	11.1	15.7	18.0	18.9
Inrush current (A)	8.0	8.0	8.0	4.0	4.0	2.5	2.5	2.5
24 VDC power supply								
Voltage (V)	24 (-15% to +20%) <sup>2)</sup>							
Maximum current (A)	When using a motor without a brake: 1.6 A When using a motor with a brake: 1.6 A + motor holding brake rated current (See Section Technical data - servo motors (Page 65)".)							
Ripple caused by the rectifier	≤ 5%							
Safety insulation class	PELV							

- 1) The values here are calculated at rated load.
- 2) When SINAMICS V90 works with a motor with a brake, the voltage tolerance of 24 VDC power supply must be -10% to +10% to meet the voltage requirement of the brake.

## 2.7.2 Technical data - servo motors

### 2.7.2.1 1FL6 servo motor - low inertia

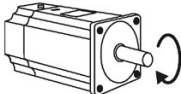
#### General technical data

Parameter	Description
Type of motor	Permanent-magnet synchronous motor
Cooling	Self-cooled
Relative humidity [RH]	90% (non-condensing at 30°C )
Installation altitude [m]	≤ 1000 (without power derating)
Thermal class	B
Vibration severity grade	A (according to IEC 60034-14)
Shock resistance [m/s <sup>2</sup> ]	25 (continuous in axial direction); 50 (continuous in radial direction); 250 (in a short time of 6 ms)
Bearing lifetime [h]	> 20000 <sup>1)</sup>
Paint finish	Black
Protection degree of shaft	IP 65, with shaft oil seal
Type of construction	IM B5, IM V1, and IM V3
Positive rotation	Clockwise (default setting in servo drives) 
Certification	

<sup>1)</sup> This lifetime is only for reference. When a motor keeps running at rated speed under rated load, replace its bearing after 20,000 to 30,000 hours of service time. Even if the time is not reached, the bearing must be replaced when unusual noise, vibration, or faults are found.

#### Specific technical data

Article No. 1FL60...	22	24	32	34	42	44	52	54
Rated power [kW]	0.05	0.1	0.2	0.4	0.75	1	1.5	2
Rated torque [Nm]	0.16	0.32	0.64	1.27	2.39	3.18	4.78	6.37
Maximum torque [Nm]	0.48	0.96	1.91	3.82	7.2	9.54	14.3	19.1
Rated speed [rpm]	3000							
Maximum speed [rpm]	5000							
Rated frequency [Hz]	200							
Rated current [A]	1.2	1.2	1.4	2.6	4.7	6.3	10.6	11.6
Maximum current [A]	3.6	3.6	4.2	7.8	14.2	18.9	31.8	34.8

General information

2.7 Technical data

Article No. 1FL60...	22	24	32	34	42	44	52	54
Moment of inertia [10 <sup>-4</sup> kgm <sup>2</sup> ]	0.031	0.052	0.214	0.351	0.897	1.15	2.04	2.62
Moment of inertia (with brake) [10 <sup>-4</sup> kgm <sup>2</sup> ]	0.038	0.059	0.245	0.381	1.06	1.31	2.24	2.82
Recommended load to motor inertia ratio	Max. 30x				Max. 20x		Max. 15x	
Operating temperature [°C]	1FL602□, 1FL603□ and 1FL604□: 0 to 40 (without power derating) 1FL605□: 0 to 30 (without power derating) <sup>1)</sup>							
Storage temperature [°C]	-20 to +65							
Maximum noise level [dB]	60							
Oil seal lifetime [h]	3000 to 5000							
Encoder lifetime [h]	> 20000 <sup>3)</sup>							
Protection degree of motor body	IP 65							
Protection degree of cable end connector	IP20						-	
Holding brake								
Rated voltage (V)	24 ± 10%							
Rated current (A)	0.25		0.3		0.35		0.57	
Holding brake torque [Nm]	0.32		1.27		3.18		6.37	
Maximum brake opening time [ms]	35		75		105		90	
Maximum brake closing time [ms]	10		10		15		35	
Maximum number of emergency stops	2000 <sup>2)</sup>							
Weight								
With brake	0.7	0.9	1.5	1.9	3.7	4.2	6.8/7.0 <sup>4)</sup>	8.0/8.2 <sup>4)</sup>
Without brake	0.5	0.6	1.0	1.5	2.8	3.4	5.4/5.5 <sup>4)</sup>	6.6/6.7 <sup>4)</sup>

- 1) When the surrounding temperature is between 30 °C and 40 °C, the 1FL605 motor will have a power derating of 10%.
- 2) Restricted emergency stop operation is permissible. Up to 2000 braking operations for the motors of 0.05 kW to 1 kW, and 200 braking operations for the motors of 1.5 kW to 2 kW can be executed with 300% rotor moment of inertia as external moment of inertia from a speed of 3000 rpm without the brake being subject to an inadmissible amount of wear.
- 3) This lifetime is only for reference. When a motor keeps running at 80% rated value and the surrounding temperature is 30 °C, the encoder lifetime can be ensured.
- 4) The former value indicates the data for low inertia motors with straight connectors; the latter value indicates the data for low inertia motors with angular connectors.

**Note**

The data of rated torque, rated power, maximum torque, and armature resistance in the above table allows a tolerance of 10%.

Torque-Speed characteristics

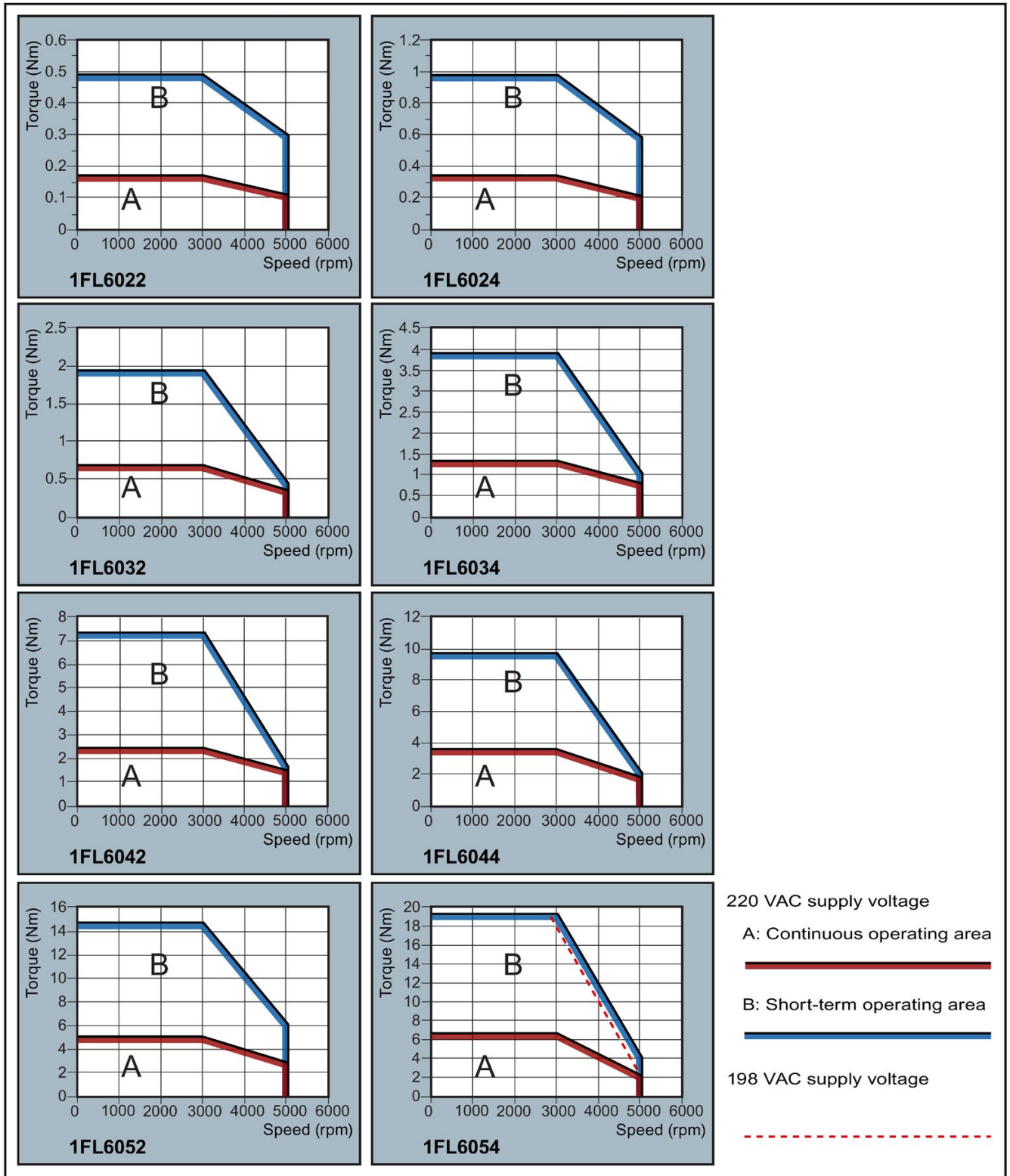

**Note**

- Continuous operating area is a series of states when a motor can operate continuously and safely. The effective torque must be located in this area.
- Short-term operating area is a series of states when a motor can operate for a short duration if its effective torque is larger than the rated torque.
- For the motors with different rated and maximum speeds, the output torque will decline at a faster rate after the speed exceeds the rated speed.
- The feature in short-term operating area varies with power supply voltages.
- The continuous operating area becomes smaller and the voltage consumptions on the cables grow larger when the cables in the major loop exceed 20 m.

**Permissible radial and axial forces**

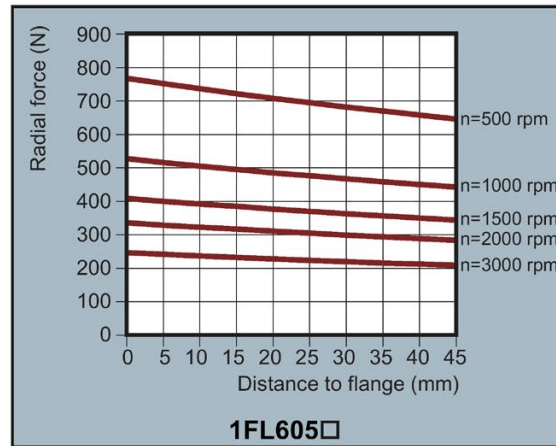
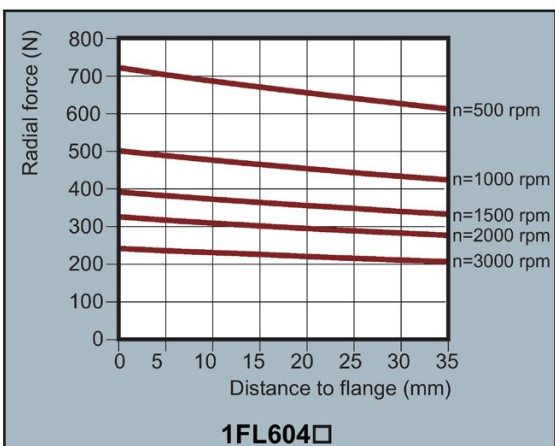
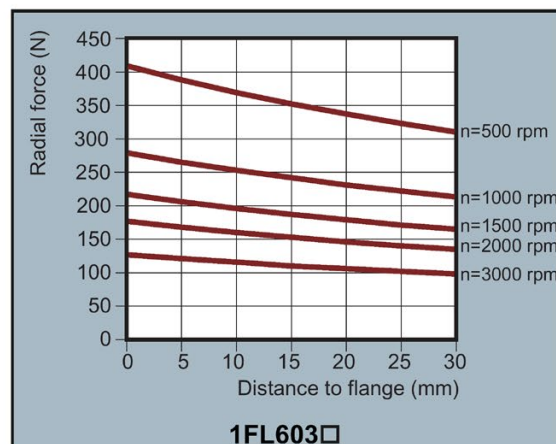
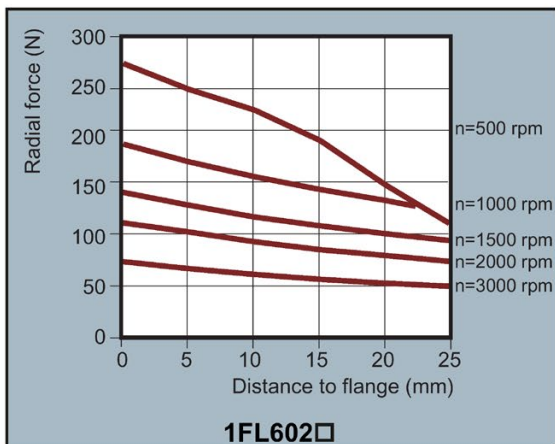

**Axial force:**

When using, for example, helical toothed wheels as drive element, in addition to the radial force, there is also an axial force on the motor bearings. For axial forces, the spring-loading of the bearings can be overcome so that the rotor moves corresponding to the axial bearing present (up to 0.2 mm).



The permissible axial force can be approximately calculated using the following formula:

$$F_A = 0.35 \cdot F_Q$$

Where  $F_A$  represents axial force and  $F_Q$  radial force.

## 2.7.2.2 1FL6 servo motor - high inertia

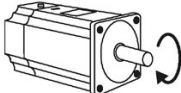
### General technical data

Parameter	Description
Type of motor	Permanent-magnet synchronous motor
Cooling	Self-cooled
Relative humidity [RH]	90% (non-condensing at 30°C )
Installation altitude [m]	≤ 1000 (without power derating)
Thermal class	B
Vibration severity grade	A (according to IEC 60034-14)
Shock resistance [m/s <sup>2</sup> ]	25 (continuous in axial direction); 50 (continuous in radial direction); 250 (in a short time of 6 ms)
Bearing lifetime [h]	> 20000 <sup>1)</sup>
Paint finish	Black
Protection degree of shaft	IP 65, with shaft oil seal
Type of construction	IM B5, IM V1, and IM V3
Positive rotation	Clockwise (default setting in servo drives) 
Certification	

<sup>1)</sup> This lifetime is only for reference. When a motor keeps running at rated speed under rated load, replace its bearing after 20,000 to 30,000 hours of service time. Even if the time is not reached, the bearing must be replaced when unusual noise, vibration, or faults are found.

### Specific technical data

Article No. 1FL60...	42	44	61	62	64	66	67	90	92	94	96
Rated power [kW]	0.40	0.75	0.75	1.00	1.50	1.75	2.00	2.5	3.5	5.0	7.0 <sup>1)</sup>
Rated torque [Nm]	1.27	2.39	3.58	4.78	7.16	8.36	9.55	11.9	16.7	23.9	33.4
Maximum torque [Nm]	3.8	7.2	10.7	14.3	21.5	25.1	28.7	35.7	50.0	70.0	90.0
Rated speed [rpm]	3000		2000				2000				
Maximum speed [rpm]	4000		3000				3000		2500	2000	
Rated frequency [Hz]	200		133				133				
Rated current [A]	1.2	2.1	2.5	3.0	4.6	5.3	5.9	7.8	11.0	12.6	13.2
Maximum current [A]	3.6	6.3	7.5	9.0	13.8	15.9	17.7	23.4	33.0	36.9	35.6
Moment of inertia [10 <sup>-4</sup> kgm <sup>2</sup> ]	2.7	5.2	8.0	15.3/ 11.7 <sup>2)</sup>	15.3	22.6	29.9	47.4	69.1	90.8	134.3

General information

2.7 Technical data

Article No. 1FL60...	42	44	61	62	64	66	67	90	92	94	96
Moment of inertia (with brake) [10 <sup>-4</sup> kgm <sup>2</sup> ]	3.2	5.7	9.1	16.4/ 13.5 <sup>2)</sup>	16.4	23.7	31.0	56.3	77.9	99.7	143.2
Recommended load to motor inertia ratio	Max. 10×		Max. 5×				Max. 5×				
Operating temperature [°C]	0 to 40 (without power derating)										
Storage temperature [°C]	-20 to +65										
Maximum noise level [dB]	65		70				70				
Oil seal lifetime [h]	5000										
Encoder lifetime [h]	> 20000 <sup>4)</sup>										
Degree of protection	IP65, with shaft oil seal										
Holding brake											
Rated voltage (V)	24 ± 10%										
Rated current (A)	0.88		1.44				1.88				
Holding brake torque [Nm]	3.5		12				30				
Maximum brake opening time [ms]	60		180				220				
Maximum brake closing time [ms]	45		60				115				
Maximum number of emergency stops	2000 <sup>3)</sup>										
Oil seal lifetime [h]	5000										
Encoder lifetime [h]	> 20000 <sup>4)</sup>										
Degree of protection	IP65, with shaft oil seal										
Weight of incremental encoder motor [kg]											
With brake <sup>2)</sup>	4.6/	6.4/	8.6/	11.3/	11.3/	14.0/	16.6/	21.3/	25.7/	30.3/	39.1/
	4.8	6.6	8.8	10.1	11.5	14.2	16.8	21.5	25.9	30.5	39.3
Without brake <sup>2)</sup>	3.3/	5.1/	5.6/	8.3/	8.3/	11.0/	13.6/	15.3/	19.7/	24.3/	33.2/
	3.4	5.2	5.7	7.0	8.4	11.1	13.7	15.4	19.8	24.4	33.3
Weight of absolute encoder motor [kg]											
With brake <sup>2)</sup>	4.4/	6.2/	8.3/	11.0/	11.0/	13.6/	16.3/	20.9/	25.3/	29.9/	38.7/
	4.5	6.3	8.4	9.7	11.1	13.7	16.4	21.0	25.4	30.0	38.8
Without brake <sup>2)</sup>	3.1/	4.9/	5.3/	8.0/	8.0/	10.7/	13.3/	14.8/	19.3/	23.9/	32.7/
	3.2	5.0	5.4	6.7	8.1	10.8	13.4	14.9	19.4	24.0	32.8

- 1) When the surrounding temperature is between 30 °C and 40 °C, the 1FL6096 motors with brake will have a power derating of 10%.
- 2) The former value indicates the data for high inertia motors with straight connectors; the latter value indicates the data for high inertia motors with angular connectors.
- 3) Restricted emergency stop operation is permissible. Up to 2000 braking operations can be executed with 300% rotor moment of inertia as external moment of inertia from a speed of 3000 rpm without the brake being subject to an inadmissible amount of wear.
- 4) This lifetime is only for reference. When a motor keeps running at 80% rated value and the surrounding temperature is 30 °C, the encoder lifetime can be ensured.



**Note**

The data of rated torque, rated power, and maximum torque in the above table allows a tolerance of 10%.

**Torque-Speed characteristics**

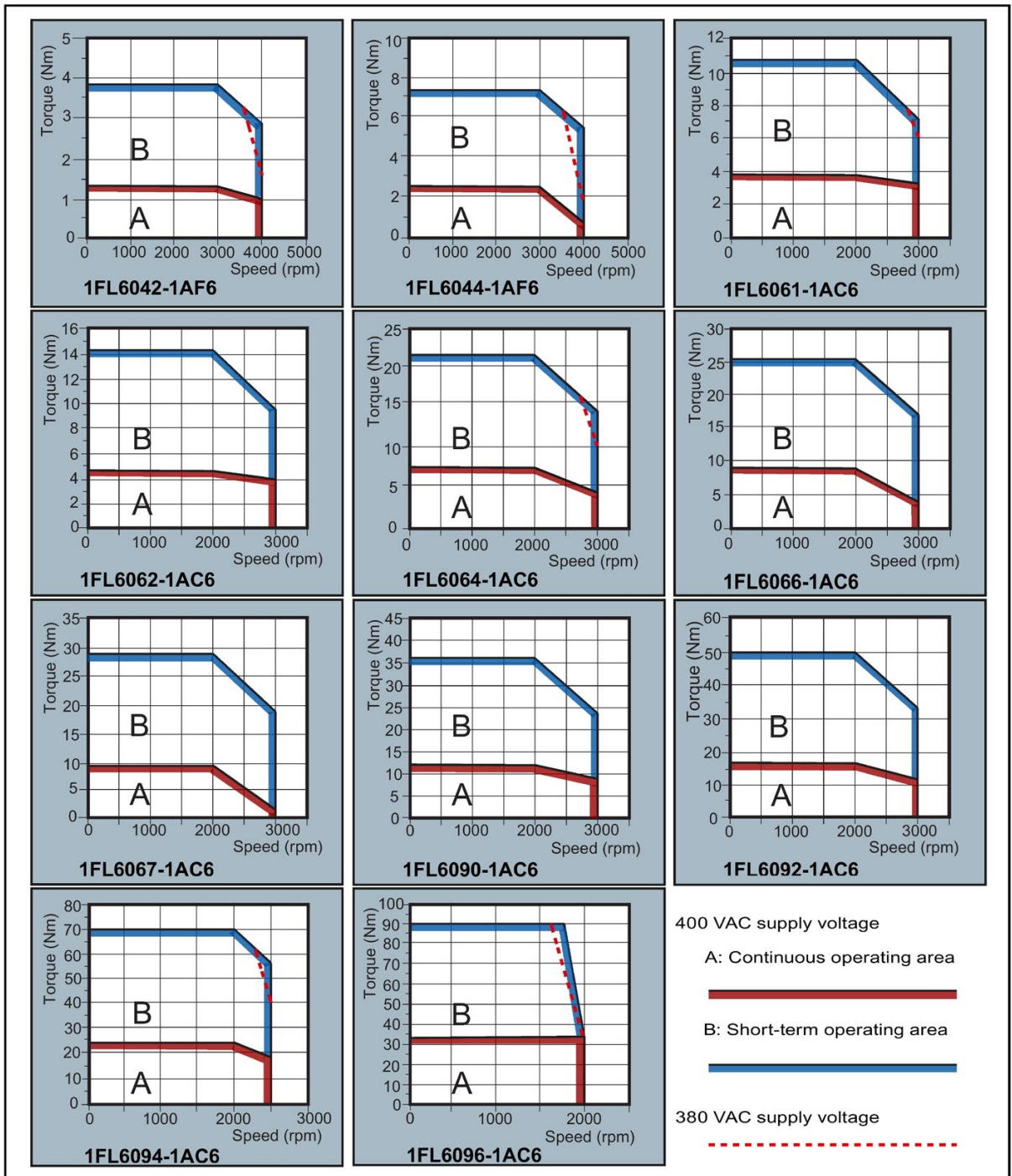

**Note**

- Continuous operating area is a series of states when a motor can operate continuously and safely. The effective torque must be located in this area.
- Short-term operating area is a series of states when a motor can operate for a short duration if its effective torque is larger than the rated torque.
- For the motors with different rated and maximum speeds, the output torque will decline at a faster rate after the speed exceeds the rated speed.
- The feature in short-term operating area varies with power supply voltages.
- The continuous operating area becomes smaller and the voltage consumptions grows larger when the cables in the major loop exceed 20 meters.
- For 1FL6096 motors, the maximum speed can be ensured when the line supply voltage is higher than 380V.

**Permissible radial and axial forces**

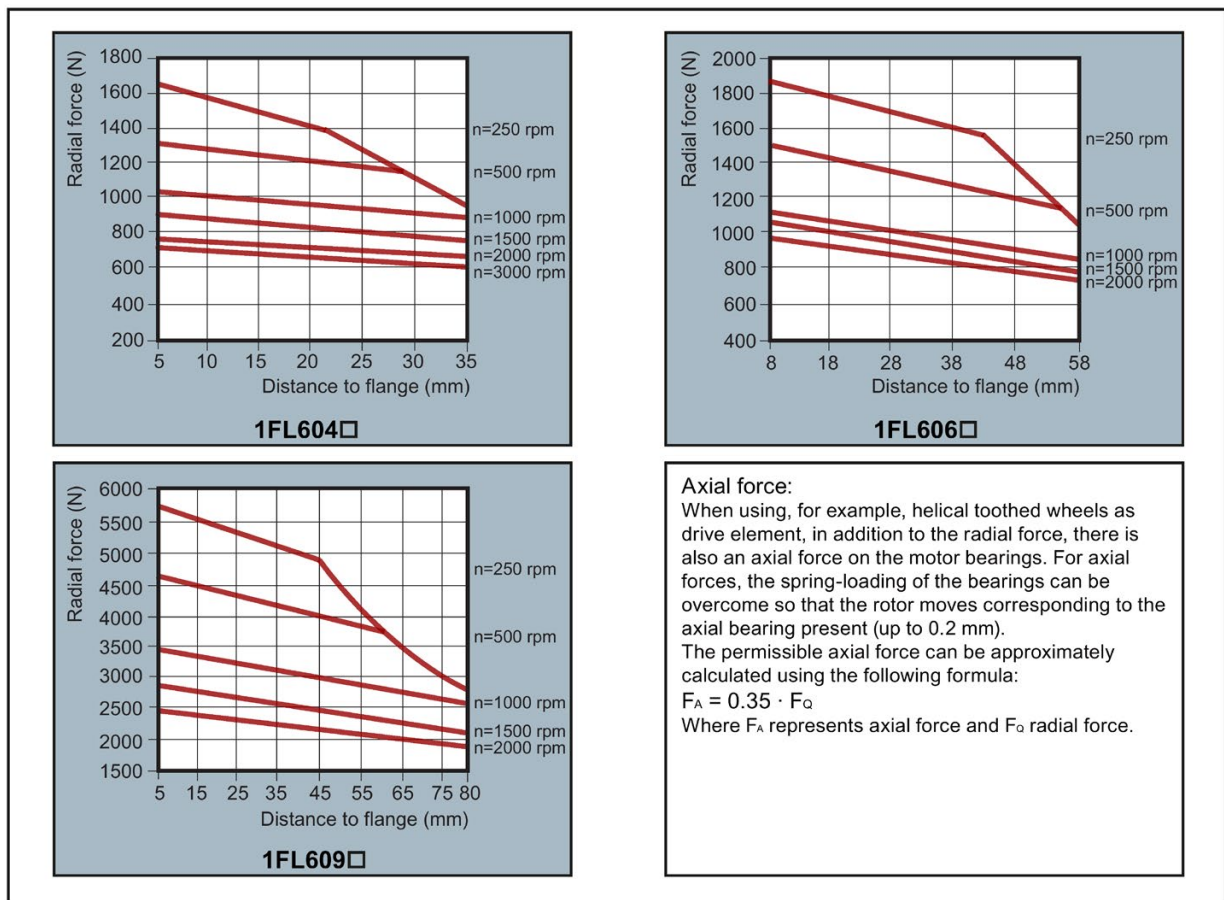

**Note**

1FL604 and 1FL609 have a 5 mm of shaft sheltered in sleeves, and 1FL606 has an 8 mm of shaft in sleeves. Therefore, the distances to flange in the above three figures begin respectively from 5 mm, 8mm, and 5 mm.

### 2.7.2.3 Power derating

For deviating conditions (surrounding temperature > 40 °C or installation altitude > 1000 m above sea level) the permissible torque/power must be determined from the following table. Surrounding temperatures and installation altitudes are rounded off to 5 °C and 500 m respectively.

#### Power derating as a function of the installation altitude and ambient temperature

Installation altitude above sea level (m)	Surrounding temperature in °C				
	< 30	30 to 40	45	50	55
1000	1.07	1.00	0.96	0.92	0.87
1500	1.04	0.97	0.93	0.89	0.84
2000	1.00	0.94	0.90	0.86	0.82
2500	0.96	0.90	0.86	0.83	0.78
3000	0.92	0.86	0.82	0.79	0.75
3500	0.88	0.82	0.79	0.75	0.71
4000	0.82	0.77	0.74	0.71	0.67

### 2.7.3 Technical data - cables

Parameter	MOTION-CONNECT 300 Power Cable	MOTION-CONNECT 300 Encoder Cable	MOTION-CONNECT 300 Brake Cable
<b>General technical data</b>			
Jacket material	PVC	PVC	PVC
Number of cores	4	10	2
Operation temperature (°C)	-25 to 80		
Shielding	Yes <ul style="list-style-type: none"> <li>• Coverage ≥ 60%: For 200 V variant servo drives + low inertia motors of 0.05 kW to 1 kW</li> <li>• Coverage ≥ 85%: For 200 V variant servo drives + low inertia motors of 1.5 kW to 2 kW, and for 400 V variant servo drives + high inertia motors of 0.4 kW to 7 kW</li> </ul>		
Minimum bending radius, static (mm)	5 x outer diameter		
Minimum bending radius, dynamic (mm)	155		
Oil resistance	EN60811-2-1 fulfilled		
Flame-retardant	EN60332-1-1 to 1-3 fulfilled		
Certification	RoHS, CE	RoHS	RoHS

2.7 Technical data

Parameter	MOTION-CONNECT 300 Power Cable	MOTION-CONNECT 300 Encoder Cable	MOTION-CONNECT 300 Brake Cable
<b>Specific technical data</b>			
Cable used for 200 V variant servo drive + low inertia motor of 0.05 kW to 1 kW			
Rated voltage (V)	300/500	30	30
Cross-section of cores (mm <sup>2</sup> )	4 x 0.75	3 x 2 x 0.20 + 4 x 0.25	2 x 0.75
Outer diameter (mm)	∅ (6.7±0.4)	∅ (7.2±0.3)	∅ (6.1±0.3)
Degree of protection (motor-side only)	IP20		
Bending cycles	100000: Maximum acceleration 3 m/s <sup>2</sup> , maximum speed 40 m/min		
Cable used for 200 V variant servo drives + low inertia motors of 1.5 kW to 2 kW, and for 400 V variant servo drives + high inertia motors of 0.4 kW to 7 kW			
Cross-section of cores (mm <sup>2</sup> )	<ul style="list-style-type: none"> <li>• 4 x 1.5: For high inertia motors of 0.4 kW to 1 kW</li> <li>• 4 x 2.5: For low inertia motors of 1.5 kW to 2 kW and high inertia motors of 1.5 kW to 7 kW</li> </ul>	3 x 2 x 0.22 + 4 x 0.25	2 x 0.75
Rated voltage (V)	600/1000	30	30
Outer diameter (mm)	<ul style="list-style-type: none"> <li>• ∅ (7.8±0.3): For high inertia motors of 0.4 kW to 1 kW</li> <li>• ∅ (9.0±0.4): For low inertia motors of 1.5 kW to 2 kW and high inertia motors of 1.5 kW to 7 kW</li> </ul>	∅ (6.9±0.3)	∅ (6.0±0.3)
Degree of protection (motor-side only)	IP65		
Bending cycles	1000000: Maximum acceleration 3 m/s <sup>2</sup> , maximum speed 40 m/min		

## 2.7.4 Address of CE-authorized manufacturer

The CE Declaration of Conformity is held on file available to the competent authorities at the following address:

### **SINAMICS V90 drive**

Siemens AG  
Digital Factory  
Motion Control  
Frauenauracher Straße 80  
DE-91056 Erlangen  
Germany

### **SIMOTICS S-1FL6 motor**

Siemens AG  
Digital Factory  
Motion Control  
Industriestraße 1  
DE-97615 Bad Neustadt a. d. Saale  
Germany

# Mounting

## 3.1 Mounting the drive

### Protection against the spread of fire

The device may be operated only in closed housings or in control cabinets with protective covers that are closed, and when all of the protective devices are used. The installation of the device in a metal control cabinet or the protection with another equivalent measure must prevent the spread of fire and emissions outside the control cabinet.

### Protection against condensation or electrically conductive contamination

Protect the device, e.g. by installing it in a control cabinet with degree of protection IP54 according to IEC 60529 or NEMA 12. Further measures may be necessary for particularly critical operating conditions.

If condensation or conductive pollution can be excluded at the installation site, a lower degree of control cabinet protection may be permitted.

#### WARNING

##### Death or severe personal injury from harsh installation environment

A harsh installation environment can jeopardize personal safety and equipment.

- Do not install the drive and the motor in an area subject to inflammables or combustibles, water or corrosion hazards.
- Do not install the drive and the motor in an area where it is likely to be exposed to constant vibrations or physical shocks.
- Do not keep the drive exposed to strong electro-magnetic interference.



#### CAUTION

##### Risk of injury due to touching hot surfaces

There is a risk of injury if you touch the hot surfaces, because surfaces of the drive can reach a high temperature during operation and for a short time after switching-off.

- Avoid coming into direct contact with the drive surface.

For mounting conditions, see Technical data - servo drives (Page 54).

### 3.1.1 Mounting orientation and clearance

The SINAMICS V90 200 V variant servo drives with rated power of 400 W and 750 W support vertical mounting and horizontal mounting. Other drives support vertical mounting only.

Mount the drive in a shielded cabinet by observing the mounting orientation and clearance specified in the following illustrations.

#### Mounting orientation

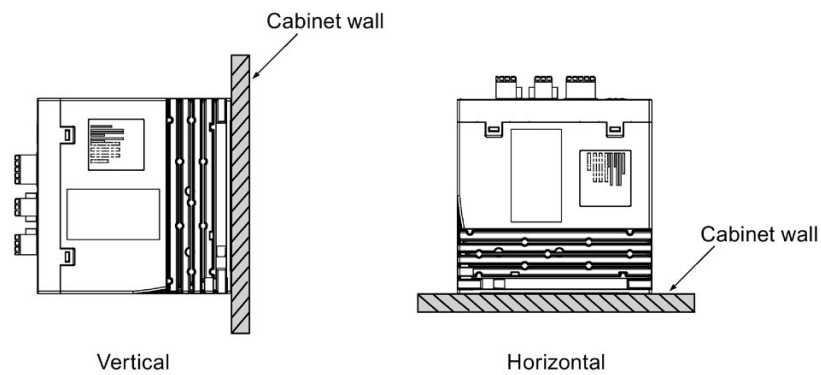

#### NOTICE

##### Overheating due to inadmissible mounting orientation

If you use an inadmissible mounting orientation, the drives can overheat and therefore be damaged.

- Always observe the mounting orientation required in the instruction.

Mounting clearance

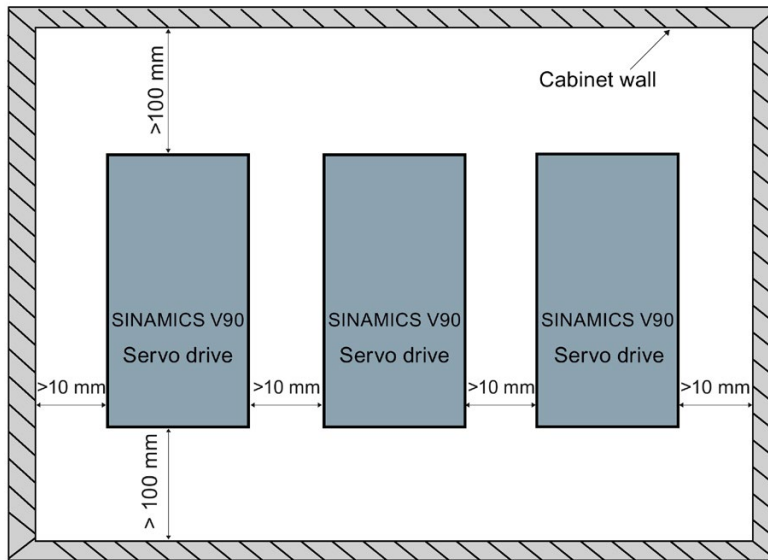

**Note**

When mounting the drive horizontally, you need to make sure the distance between the drive front panel and the top cabinet wall is larger than 100 mm.

**Note**

The drive must be derated to 80% when one of the following conditions is satisfied:

- The surrounding temperature is 0 °C to 45 °C, and the mounting clearance is less than 10 mm. In this case, the minimum mounting clearance should not be less than 5 mm.
- The surrounding temperature is 45 °C to 55 °C. In this case, the minimum mounting clearance should not be less than 20 mm.

**Note**

When mounting the drive in the cabinet, you need to consider the temperature change of the cooling air. The rapid temperature change of the cooling air is forbidden.



### 3.1.2 Drill patterns and outline dimensions

SINAMICS V90 200 V variant (unit: mm)

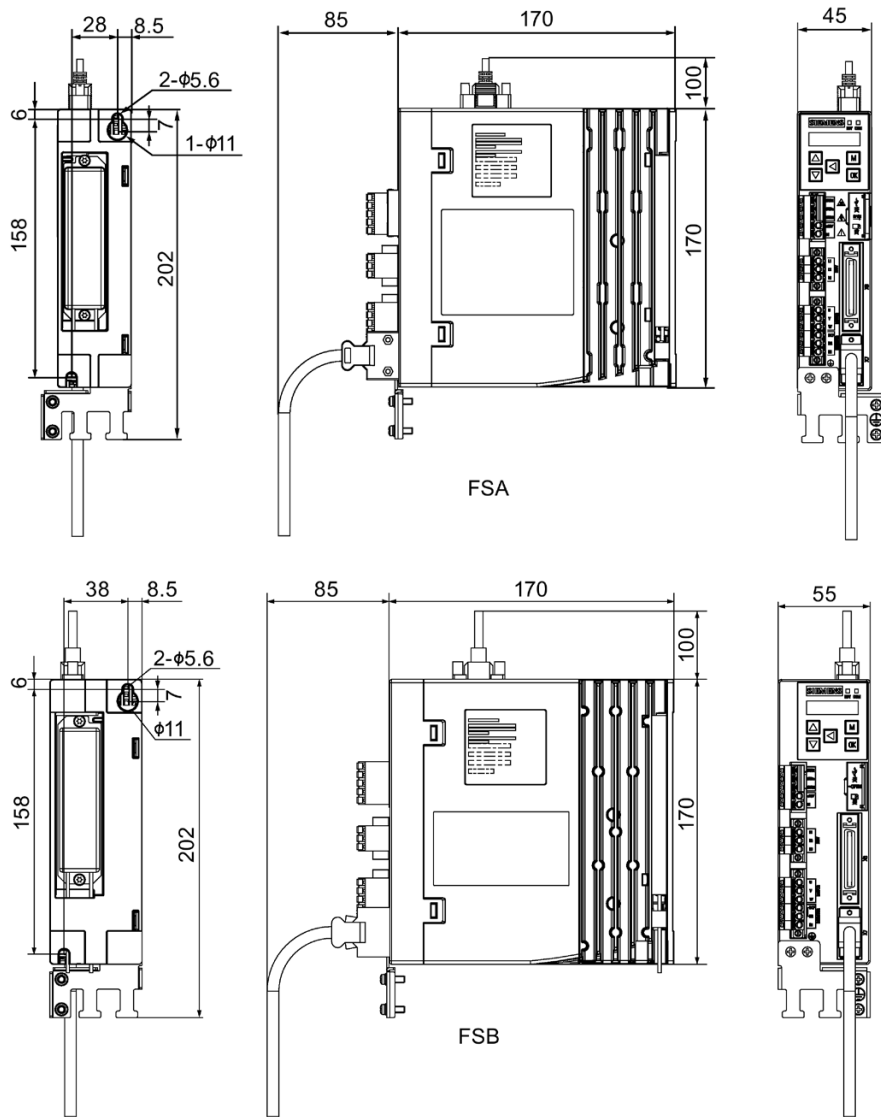

3.1 Mounting the drive

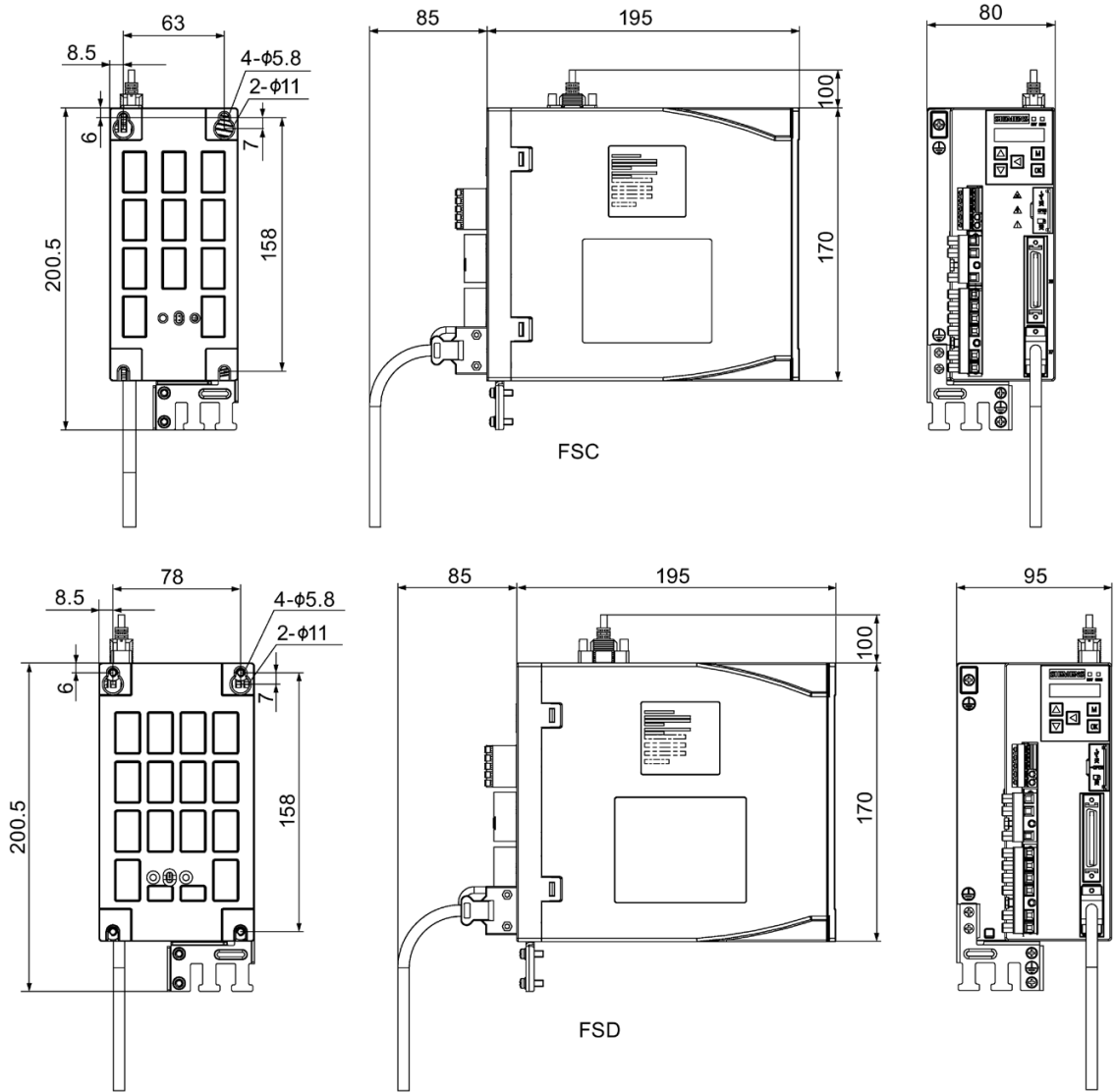

SINAMICS V90 400 V variant (unit: mm)

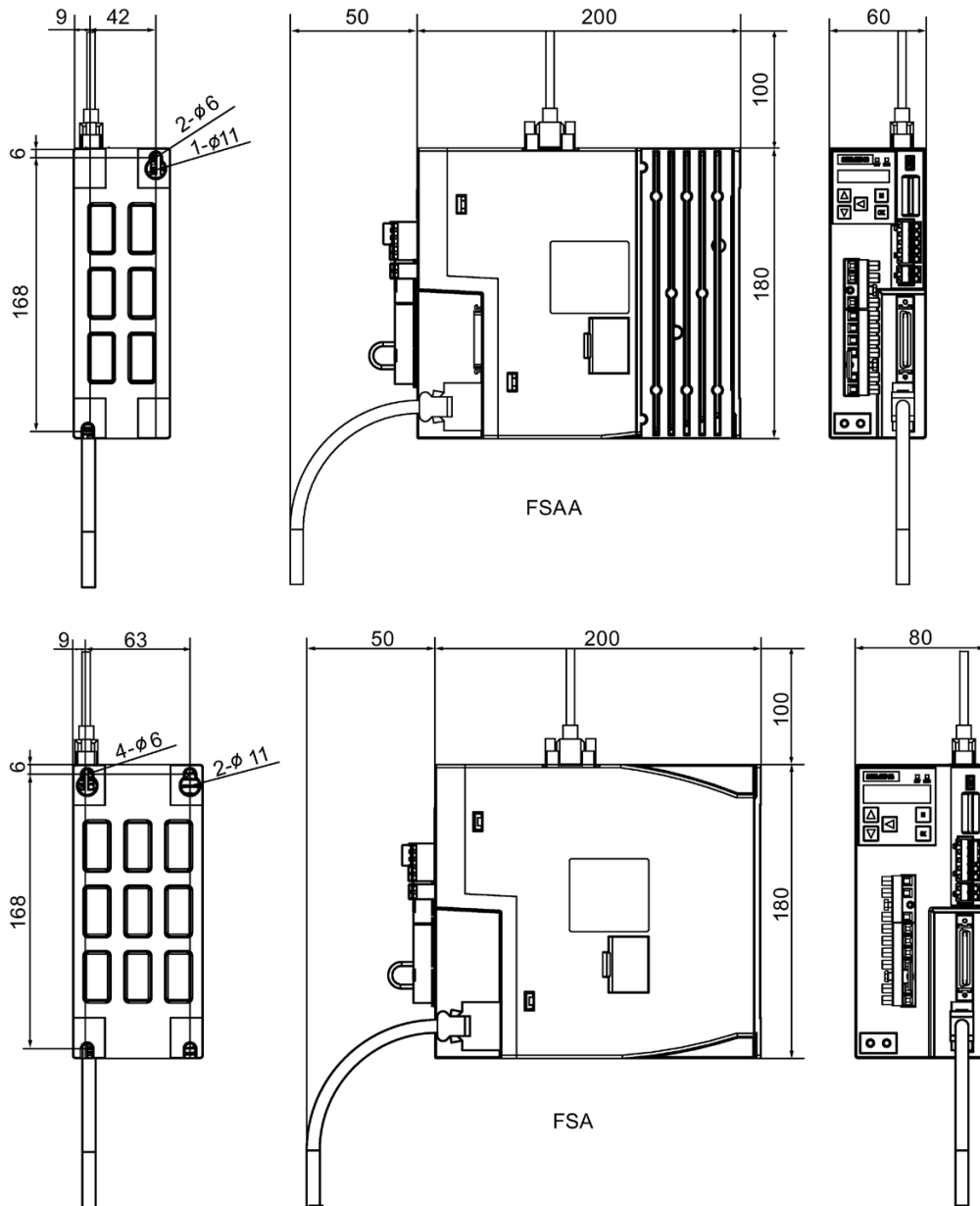

3.1 Mounting the drive

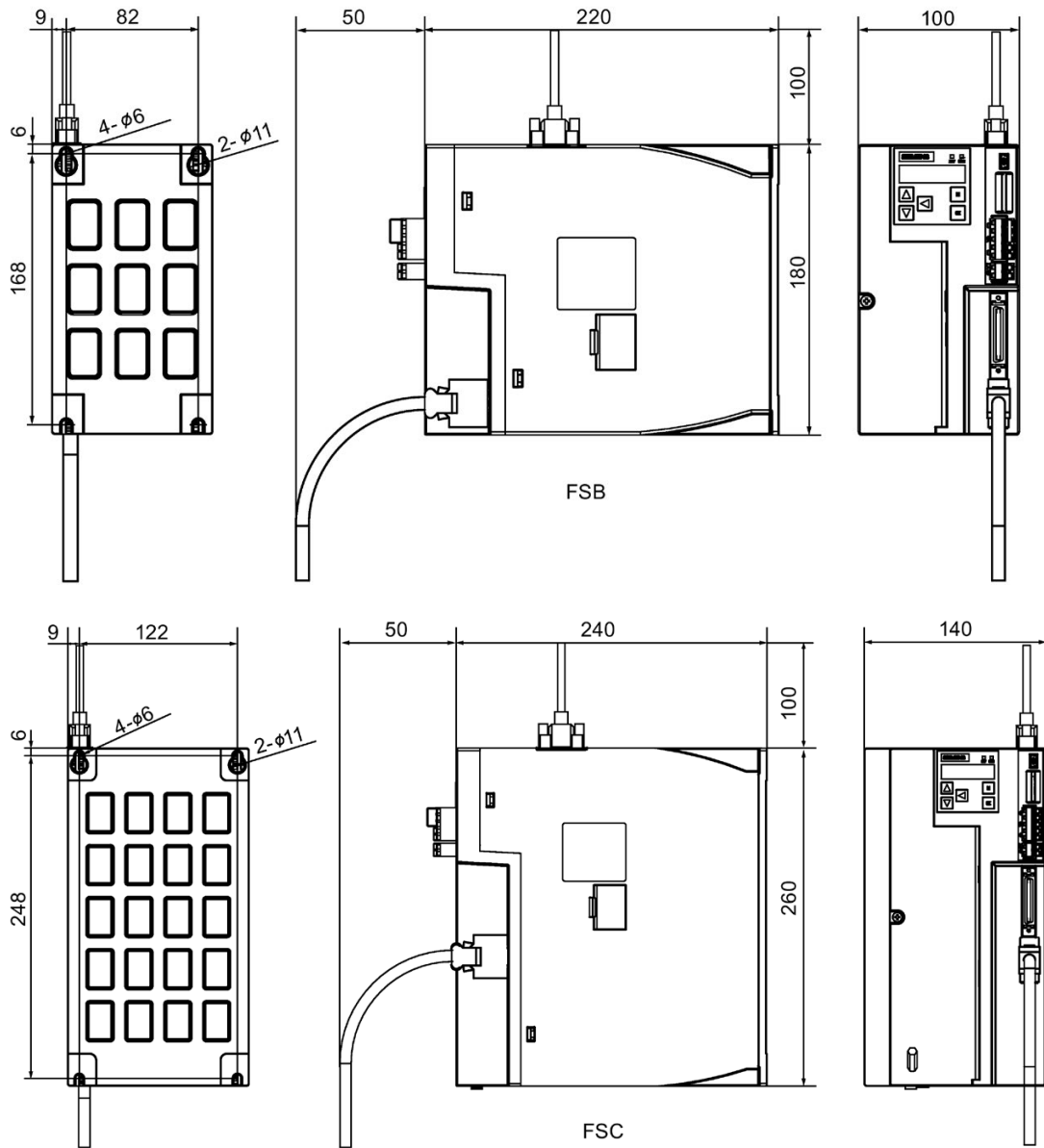

### 3.1.3 Mounting the drive

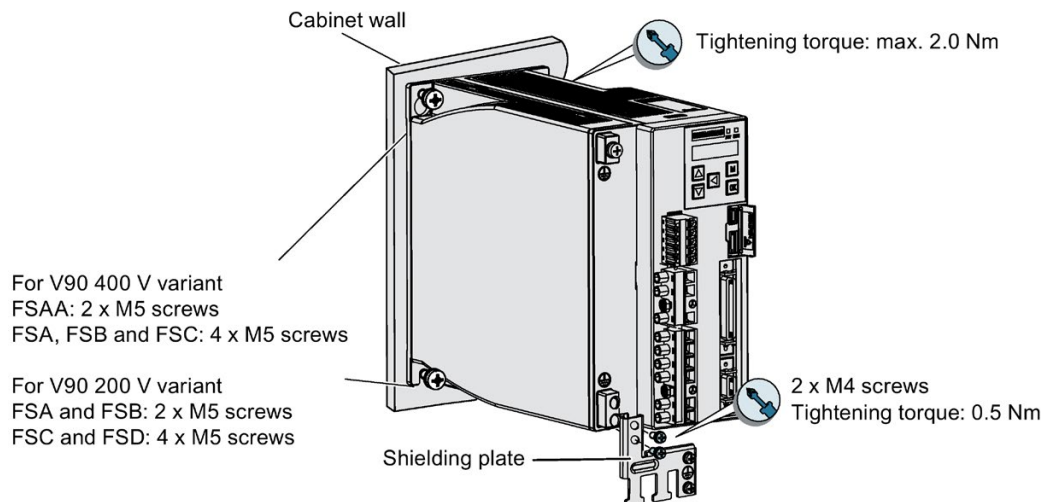

#### Note

#### EMC instructions

- To comply with the EMC standards, all cables connected with the SINAMICS V90 system must be shielded cables, which include cables from the line supply to the line filter and from the line filter to the SINAMICS V90 drive.
- Route signal cables and power cables separately in different cable conduits. The signal cables shall be at least 10 cm away from the power cables.
- The SINAMICS V90 drives have been tested in accordance with the emission requirements of the category of C2 (domestic) environment. The conductive emissions and radiated emissions are in compliance with the standard of EN 55011 and reached Class A.
- This device is designed for operation in the second environment (industrial area) and may not be used in the first environment (residential area) unless the appropriate noise suppression measures have been adopted.
- For a radiated emission test, an external AC filter (between the mains supply and the drive) will be used to meet the EMC requirement and the drive will be installed inside the shielded metallic chamber, other parts of the motion control system (including the PLC, DC power supply, spindle drive, motor) will be put inside the shielded chamber.
- For a conductive emission test, an external AC filter (between the mains supply and the drive) will be used to meet the EMC requirement.
- For the radiated emission and conductive emission test, the length of the line supply cable between the line filter and the drive must be shorter than 1 m.
- The harmonic current value of SINAMICS V90 exceed the class A limit of IEC 61000-3-2, but the SINAMICS V90 system installed within the Category C2 First Environment require supply authority acceptance for connection to the public low-voltage power supply network. Please contact your local supply network provider.

<b>NOTICE</b>
<b>Malfunction caused by radio devices or mobile phones</b>
When radio devices or mobile phones are used in the immediate vicinity of the drives (less than 20 cm), the drives can be disturbed, which can cause the drives to malfunction. This may impair the functional safety of drives and can therefore put people in danger or lead to property damage.
<ul style="list-style-type: none"><li>• If you come closer than around 20 cm to the drives, switch off any radios or mobile phones.</li></ul>

**Note**

**Screw tightening**

Make sure you fix the screw to the terminal door of the drive after you have completed the installation work.

**Note**

For the installation altitude lower than or equal to 2000 m above sea level, it is permissible to connect the drive to any of the line supplies that are specified for it. For the installation altitude higher than 2000 m and lower than 5000 m above sea level, you must connect the drive to any of the specified line supplies either via an isolating transformer or with a grounded neutral point.

### 3.2 Mounting the motor

<b>NOTICE</b>
<b>Damage to the encoder due to shocking</b>
Shocks at the motor shaft end can cause an encoder damage.
<ul style="list-style-type: none"><li>•  Do not exert any shock at the shaft end.</li></ul>

For mounting conditions, see Technical data - servo motors (Page 61).

### 3.2.1 Mounting orientation and dimensions

#### Mounting orientation

SIMOTICS S-1FL6 supports flange mounting only and three types of constructions, so it can be installed in three orientations as shown in the following figure.

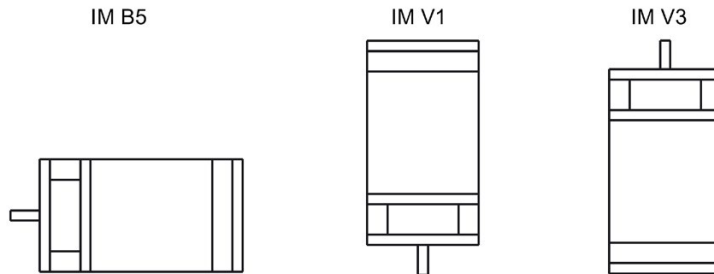

#### Note

When configuring the IM V3 type of construction, you need to pay particular attention to the permissible axial force (weight force of the drive elements) and the necessary degree of protection.

#### SIMOTICS S-1FL6 Low inertia servo motors (unit: mm)

Shaft height 20 mm

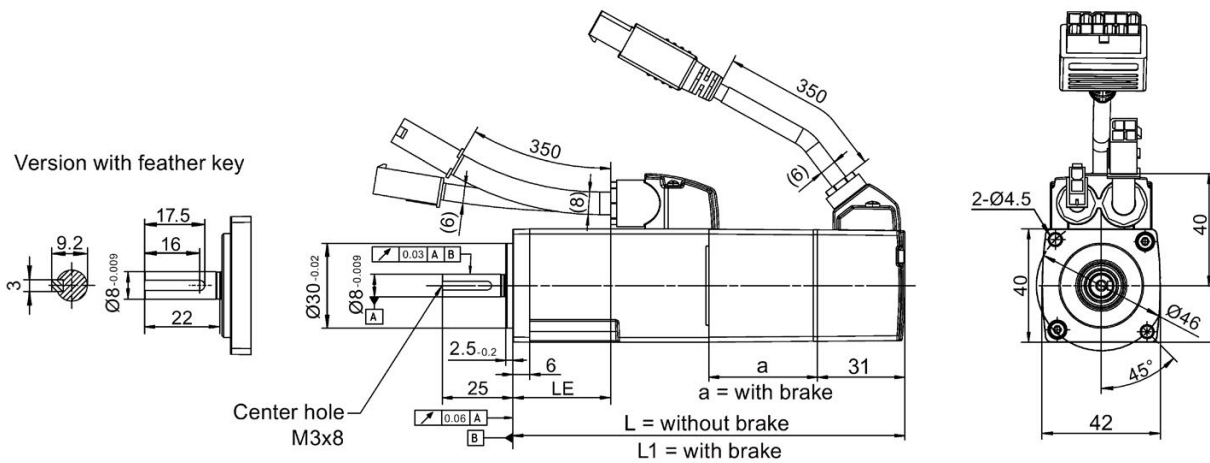

Rated power	Rated torque	a	L	L1	LE
0.05 kW	0.16 Nm	38.5	86	119	15
0.1 kW	0.32 Nm	38.5	106	139	35

3.2 Mounting the motor

Shaft height 30 mm

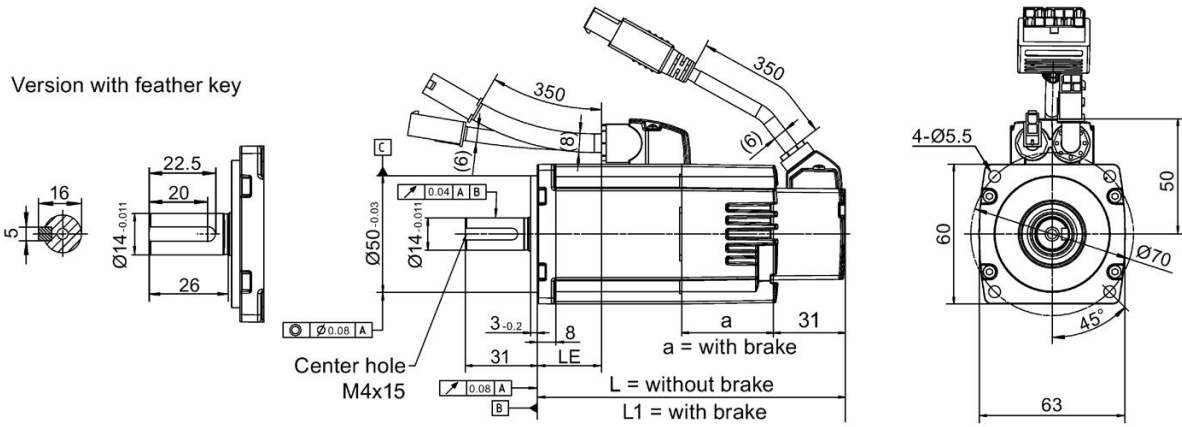

Rated power	Rated torque	a	L	L1	LE
0.2 kW	0.64 Nm	39.5	98	132.5	27
0.4 kW	1.27 Nm	39.5	123	157.5	52

Shaft height 40 mm

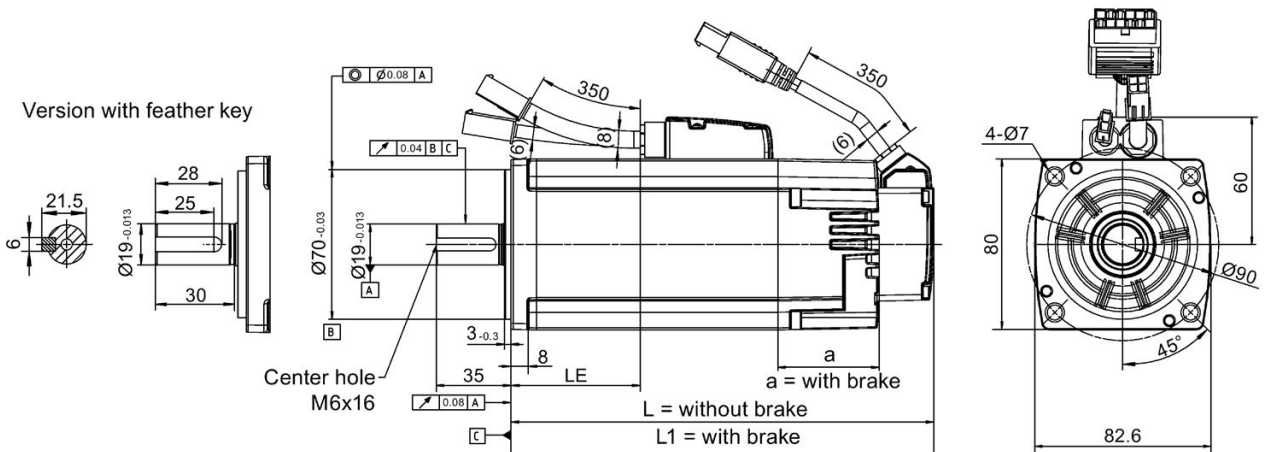

Rated power	Rated torque	a	L	L1	LE
0.75 kW	2.39 Nm	48	139	178.3	40
1.0 kW	3.18 Nm	48	158.8	198.1	60



Shaft height 50 mm, with straight connectors

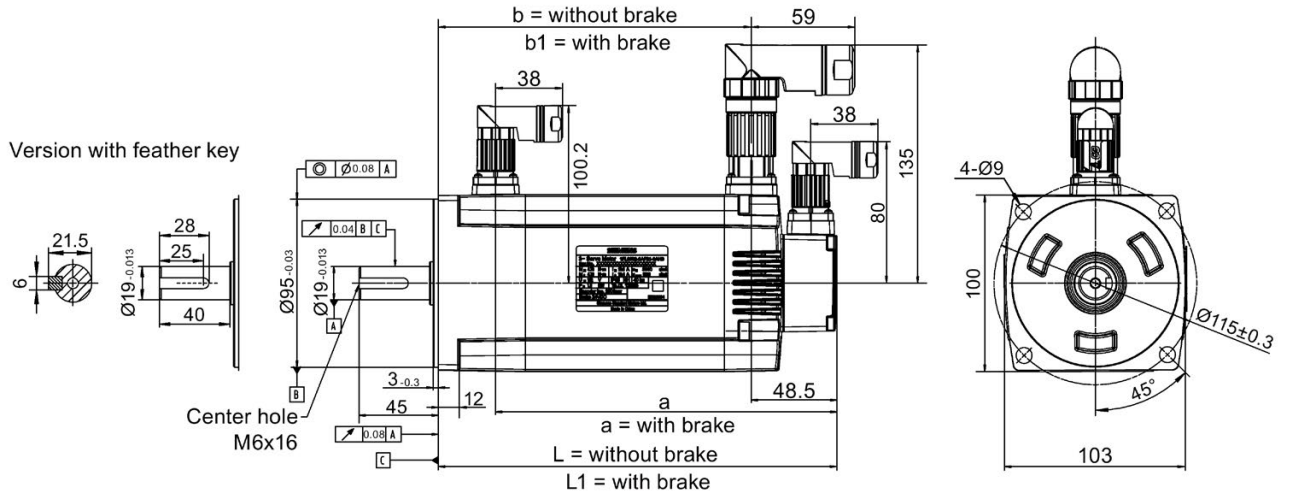

Shaft height 50 mm, with angular connectors

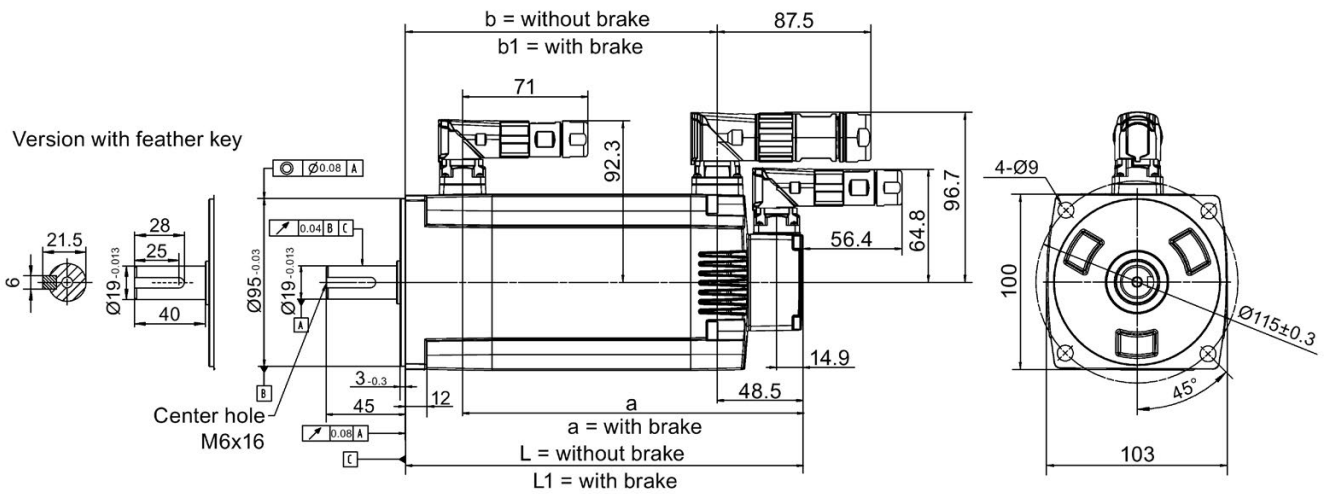

Rated power	Rated torque	a	b	b1	L	L1
1.5 kW	4.78 Nm	195	143.5	177.5	192	226
2.0 kW	6.37 Nm	219	167.5	201.5	216	250

**SIMOTICS S-1FL6 high inertia servo motors (unit: mm)**

**Shaft height 45 mm, with the incremental encoder and straight connectors**

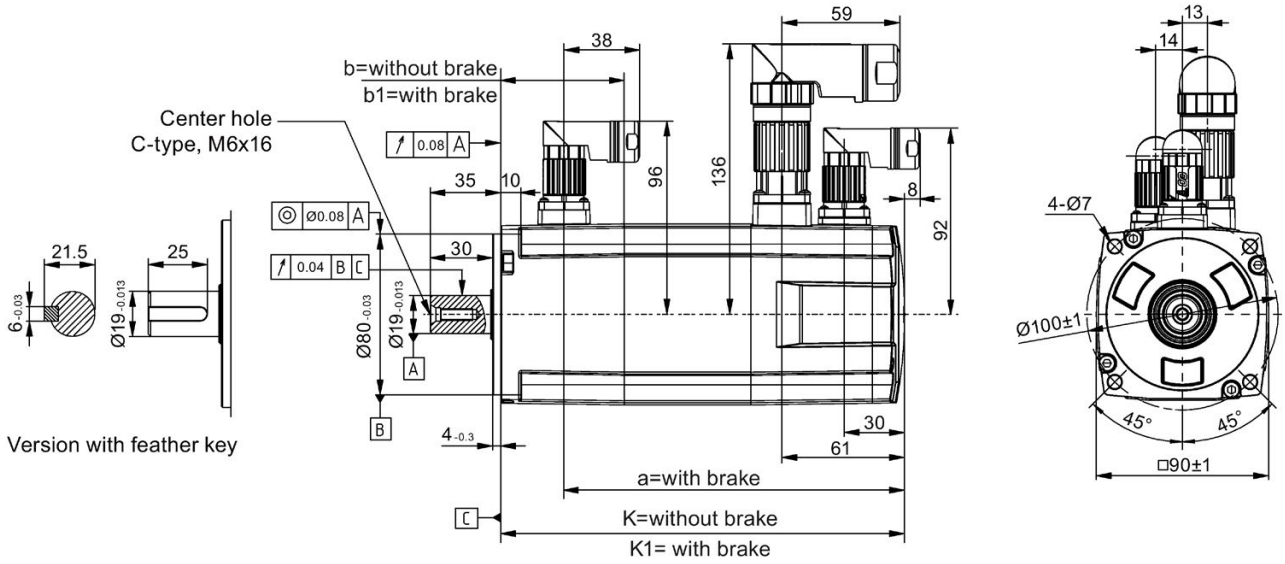

**Shaft height 45 mm, with the incremental encoder and angular connectors**

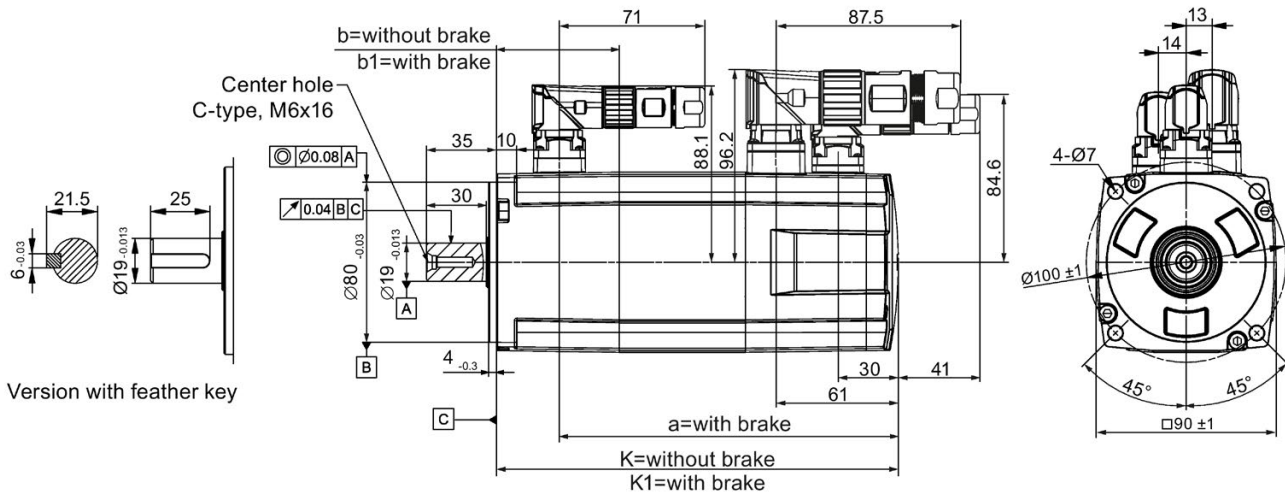

Rated power	Rated torque	K	K1	a	b	b1
0.4 kW	1.27 Nm	154.5	201	169.5	15	61.5
0.75 kW	2.39 Nm	201.5	248	216.5		

Shaft height 45 mm, with the absolute encoder and straight connectors

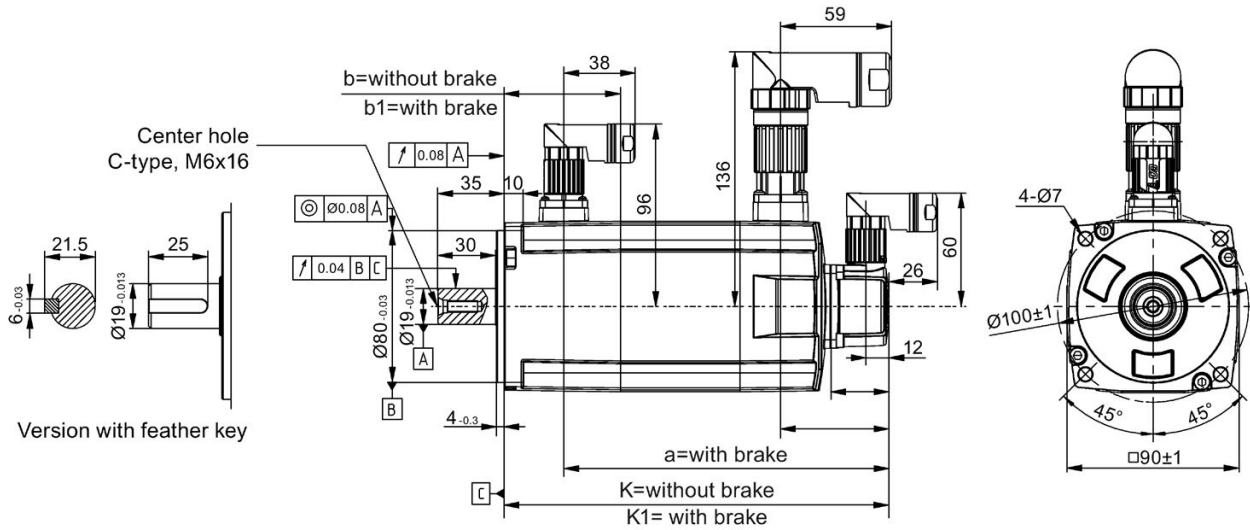

Shaft height 45 mm, with the absolute encoder and angular connectors

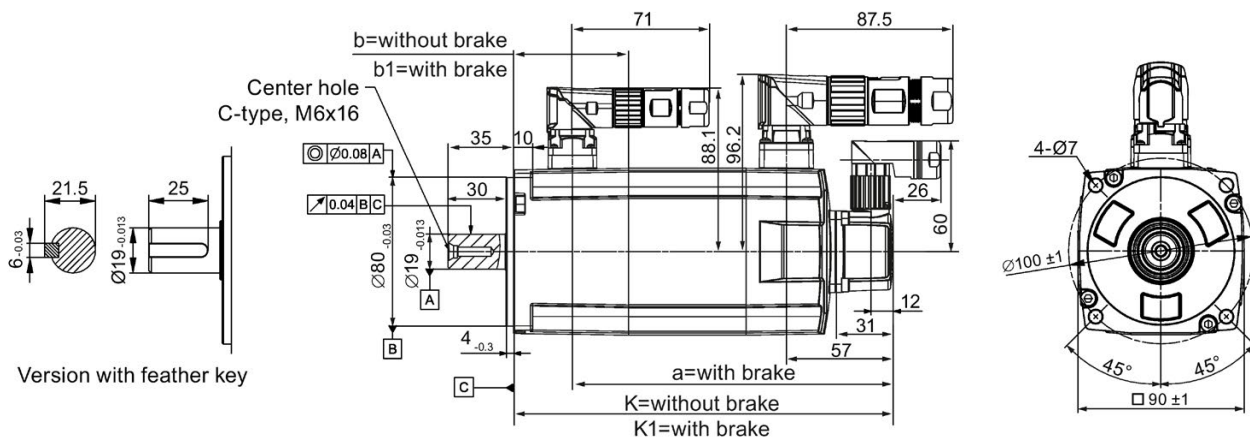

Rated power	Rated torque	K	K1	a	b	b1
0.4 kW	1.27 Nm	157	203.5	172	15	61.5
0.75 kW	2.39 Nm	204	250.5	219		

Shaft height 65 mm, with the incremental encoder and straight connectors

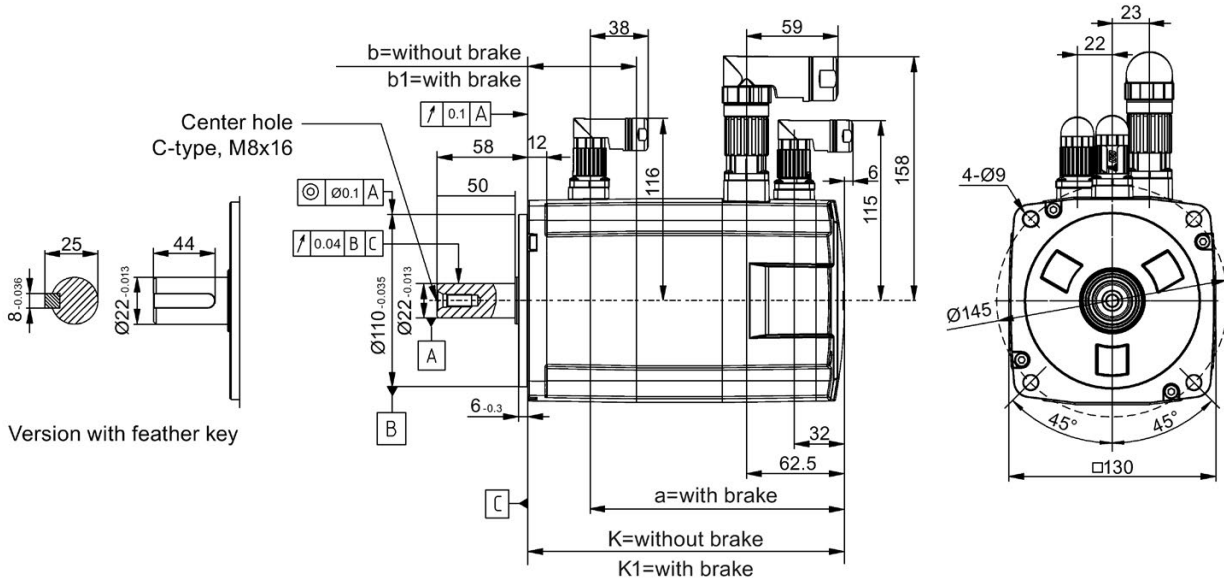

Shaft height 65 mm, with the incremental encoder and angular connectors

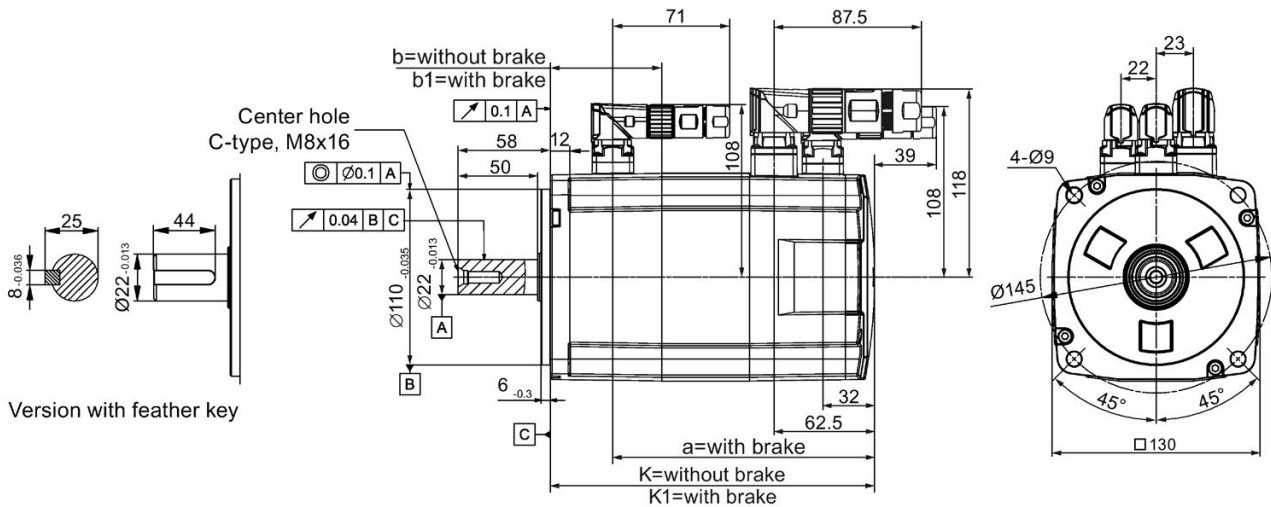

Rated power	Rated torque	K	K1	a	b	b1
0.75 kW	3.58 Nm	148	202.5	163	15	69.5
1.0 kW	4.78 Nm	181/164 <sup>1)</sup>	235.5/219 <sup>1)</sup>	196/179.5 <sup>1)</sup>		
1.5 kW	7.16 Nm	181	235.5	196		
1.75 kW	8.36 Nm	214	268.5	229		
2.0 kW	9.55 Nm	247	301.5	262		

<sup>1)</sup> The former value indicates the dimension for high inertia motors with straight connectors; the latter value indicates the dimension for high inertia motors with angular connectors.

Shaft height 65 mm, with the absolute encoder and straight connectors

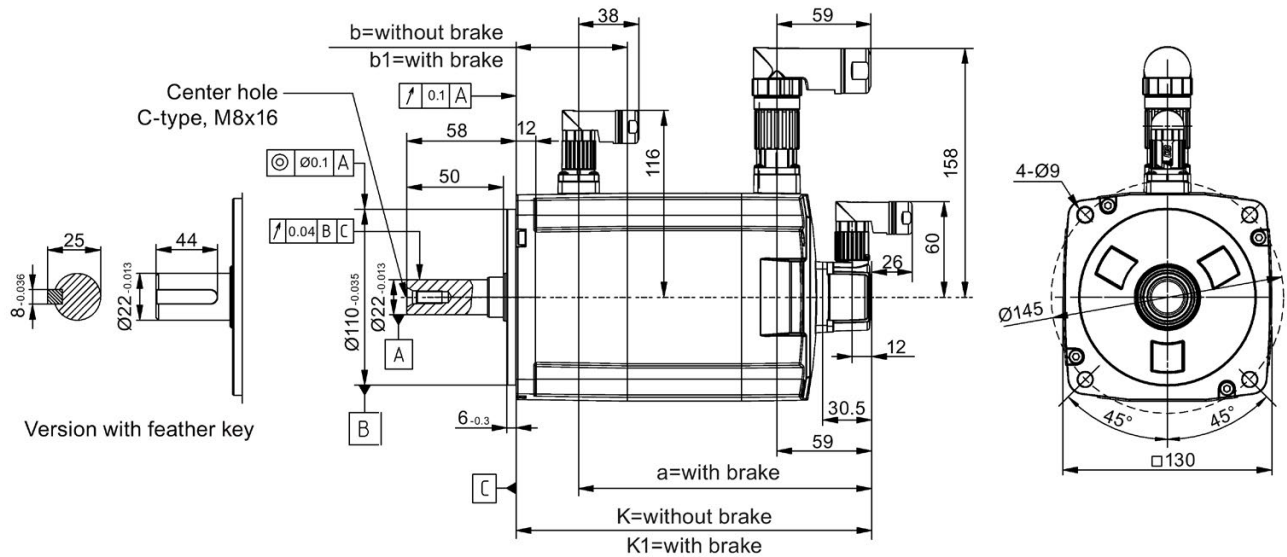

Shaft height 65 mm, with the absolute encoder and angular connectors

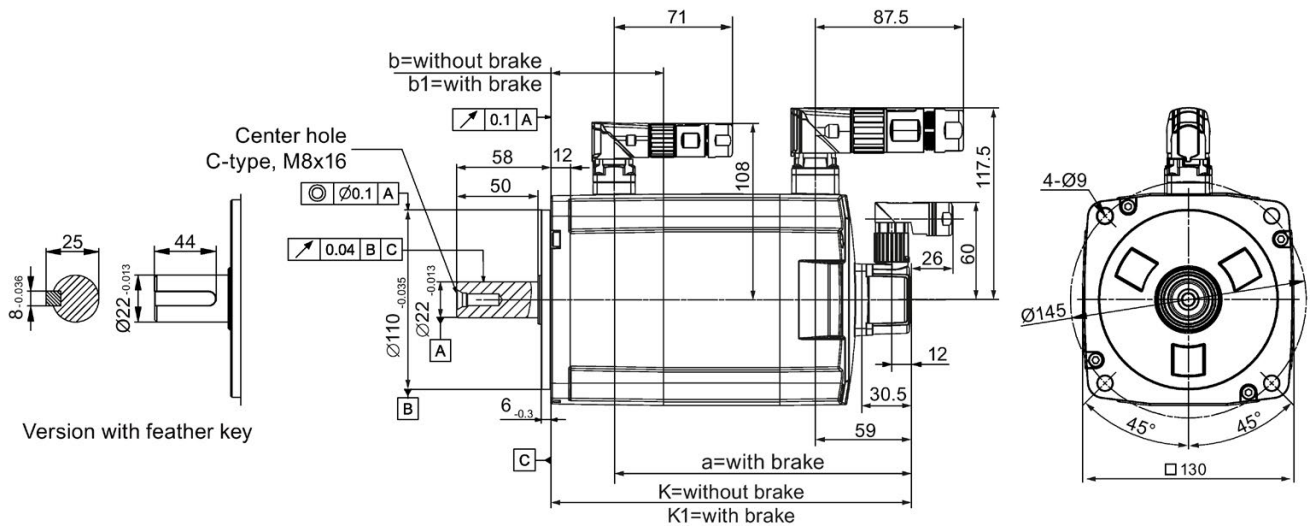

Rated power	Rated torque	K	K1	a	b	b1
0.75 kW	3.58 Nm	151	205.5	166	15	69.5
1.0 kW	4.78 Nm	184/167.5 <sup>1)</sup>	238.5/222 <sup>1)</sup>	199/182.5 <sup>1)</sup>		
1.5 kW	7.16 Nm	184	238.5	199		
1.75 kW	8.36 Nm	217	271.5	232		
2.0 kW	9.55 Nm	250	304.5	265		

<sup>1)</sup> The former value indicates the dimension for high inertia motors with straight connectors; the latter value indicates the dimension for high inertia motors with angular connectors.



3.2 Mounting the motor

Shaft height 90 mm, with the incremental encoder and straight connectors

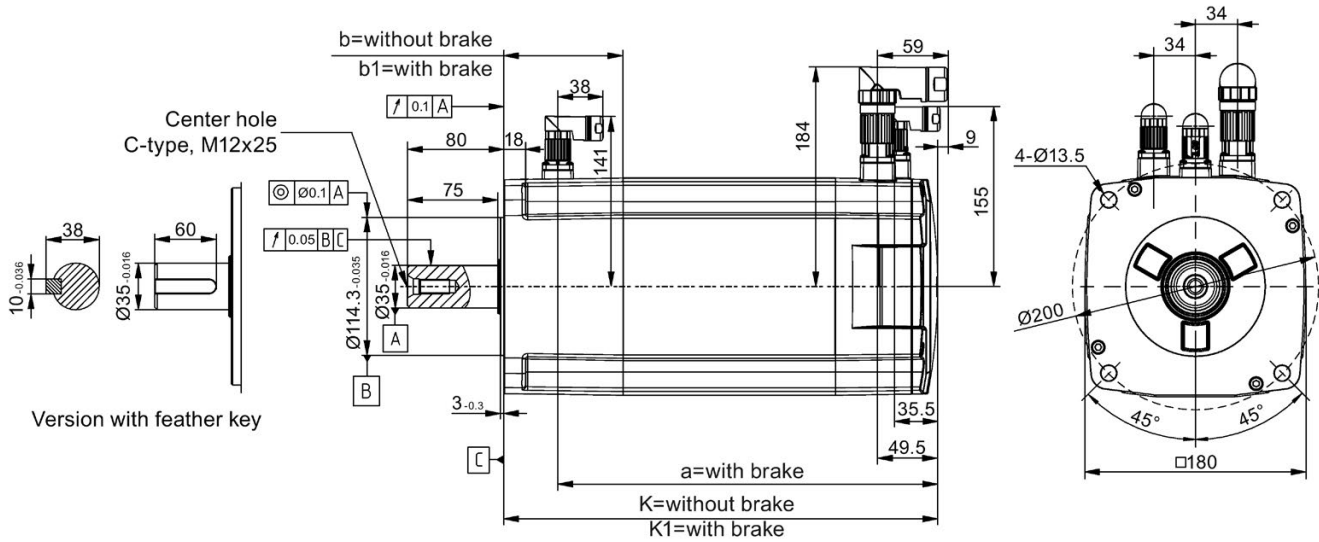

Shaft height 90 mm, with the incremental encoder and angular connectors

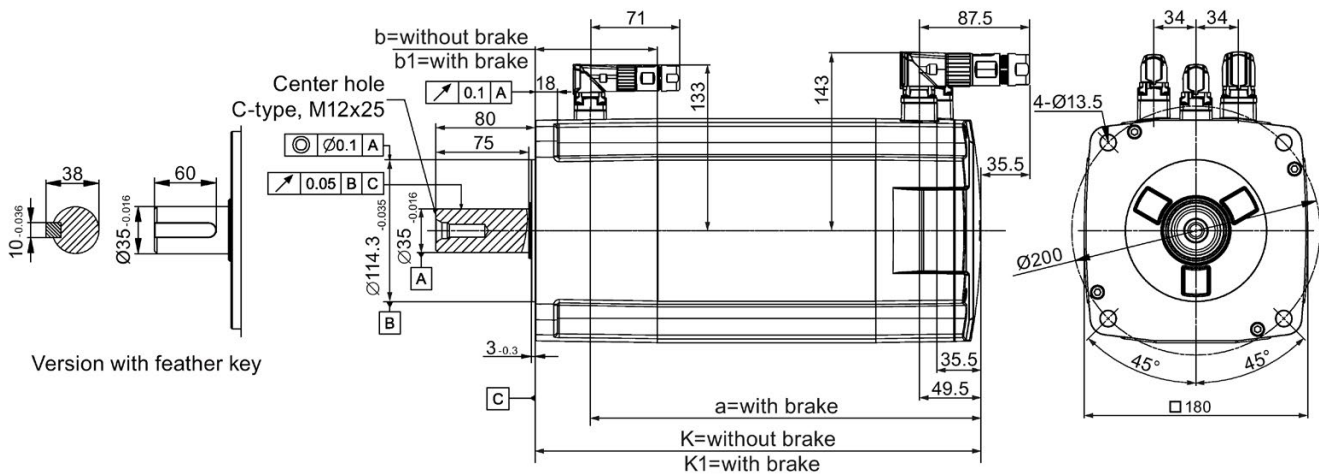

Rated power	Rated torque	K	K1	a	b	b1
2.5 kW	11.9 Nm	189.5	255	210.5	33	98.5
3.5 kW	16.7 Nm	211.5	281	236.5		
5.0 kW	23.9 Nm	237.5	307	262.5		
7.0 kW	33.4 Nm	289.5	359	314.5		

Shaft height 90 mm, with the absolute encoder and straight connectors

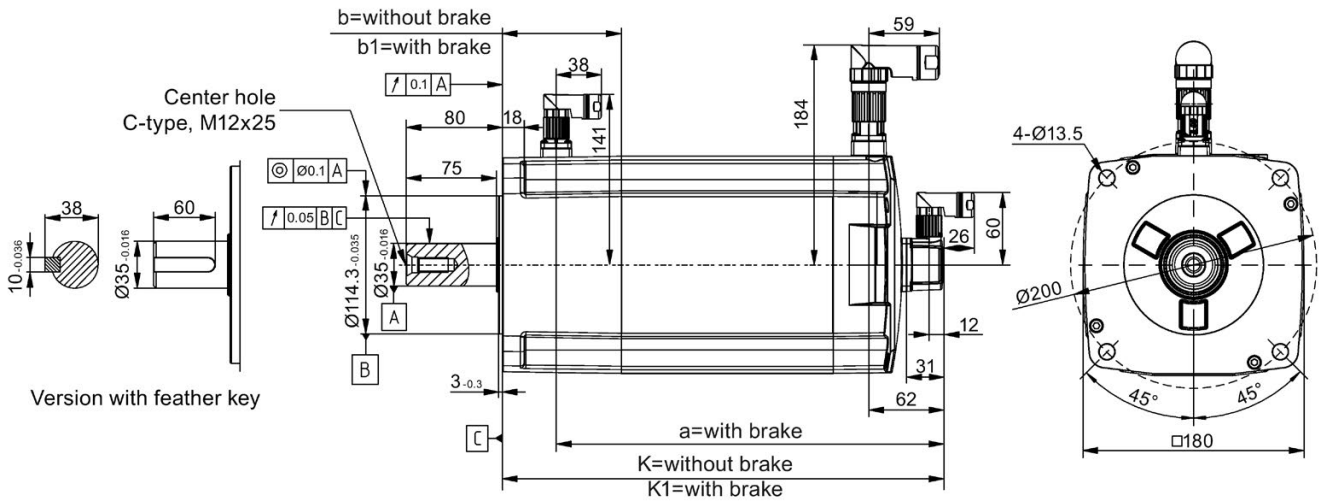

Shaft height 90 mm, with the absolute encoder and angular connectors

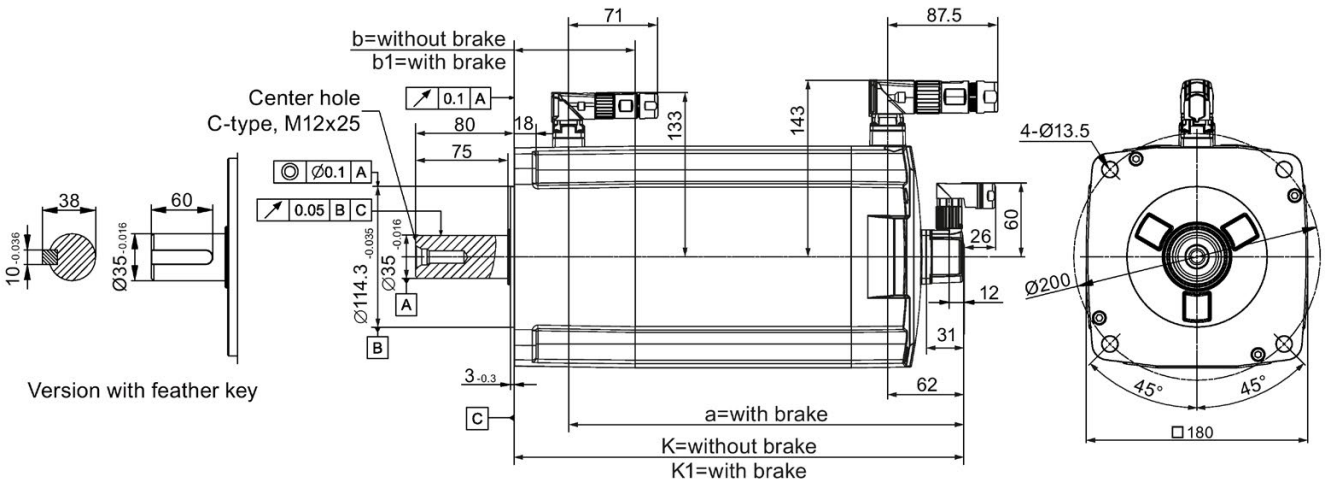

Rated power	Rated torque	K	K1	a	b	b1
2.5 kW	11.9 Nm	197	263	218	33	98.5
3.5 kW	16.7 Nm	223	289	244		
5.0 kW	23.9 Nm	249	315	270		
7.0 kW	33.4 Nm	301	367	322		

### 3.2.2 Mounting the motor

 **WARNING**

**Personal injury and material damage due to motor falling down**

Some motors, especially the 1FL609□ are heavy. Motor falling down can cause serious personal injury or material damage.

- The excessive weight of the motor should be considered and any necessary assistance required for mounting should be sought.

**NOTICE**

**Damage to the motor due to liquid entering**

If the liquid enters the motor, the motor may be damaged

- During motor installation or operation, make sure that no liquid (water, oil, etc.) can penetrate into the motor.
- When installing the motor horizontally, make sure that the cable outlet faces downward to protect the motor from ingress of oil or water.

**NOTICE**

**Damage to the absolute encoder due to the magnetic interference from the magnetic field**

The magnetic interference from the magnetic field can cause a damage to the absolute encoder.

- To avoid magnetic interference to the absolute encoder, keep the servo motor with an absolute encoder at least 15 mm away from the devices that produce a magnetic field stronger than 10 mT.

---

**Note**

**Using the eyebolts**

The 1FL609□ motor (90 mm shaft height) has two M8 screw holes for screwing in two eyebolts. Lift the 1FL609□ motor only at the eyebolts.

Eyebolts that have been screwed in must be either tightened or removed after mounting.

---



Install the motor onto a steel flange with four screws as shown in the following figure:

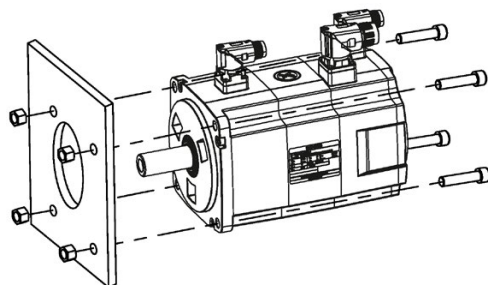

Motor	Screw	Recommended flange size	Tightening torque	Flange material
<b>Low inertia motors</b>				
1FL602□	2 x M4	120 x 100 x 40 (mm)	2.4 Nm	Steel
1FL603□	4 x M5	120 x 100 x 40 (mm)	4.7 Nm	
1FL604□	4 x M6	120 x 100 x 40 (mm)	8 Nm	
1FL605□	4 x M8	120 x 100 x 40 (mm)	20 Nm	
<b>High inertia motors</b>				
1FL604□	4 x M6	270 x 270 x 10 (mm)	8 Nm	Steel
1FL606□	4 x M8	390 x 390 x 15 (mm)	20 Nm	
1FL609□	4 x M12	420 x 420 x 20 (mm)	85 Nm	

### 3.2.3 Motor heating conditions

The rated motor specifications are continuous allowable values at a surrounding air temperature of 40 °C when the motor is installed with a steel flange. When the motor is mounted on a small surface, the motor temperature may rise considerably because of the limited heat radiating abilities of the surface. Make sure that you use a suitable flange according to Siemens-recommended flange sizes.

#### Note

The actual temperature rise depends on how the flange (motor mounting section) is fixed on the installation surface, what material is used for the motor mounting section, and motor speed. Always check the actual motor temperature.

## Connecting

### 4.1 System connection

The following illustrations show examples of the SINAMICS V90 servo system connection:

#### SINAMICS V90 200 V variant

Connection diagram for FSB on the single phase power network:

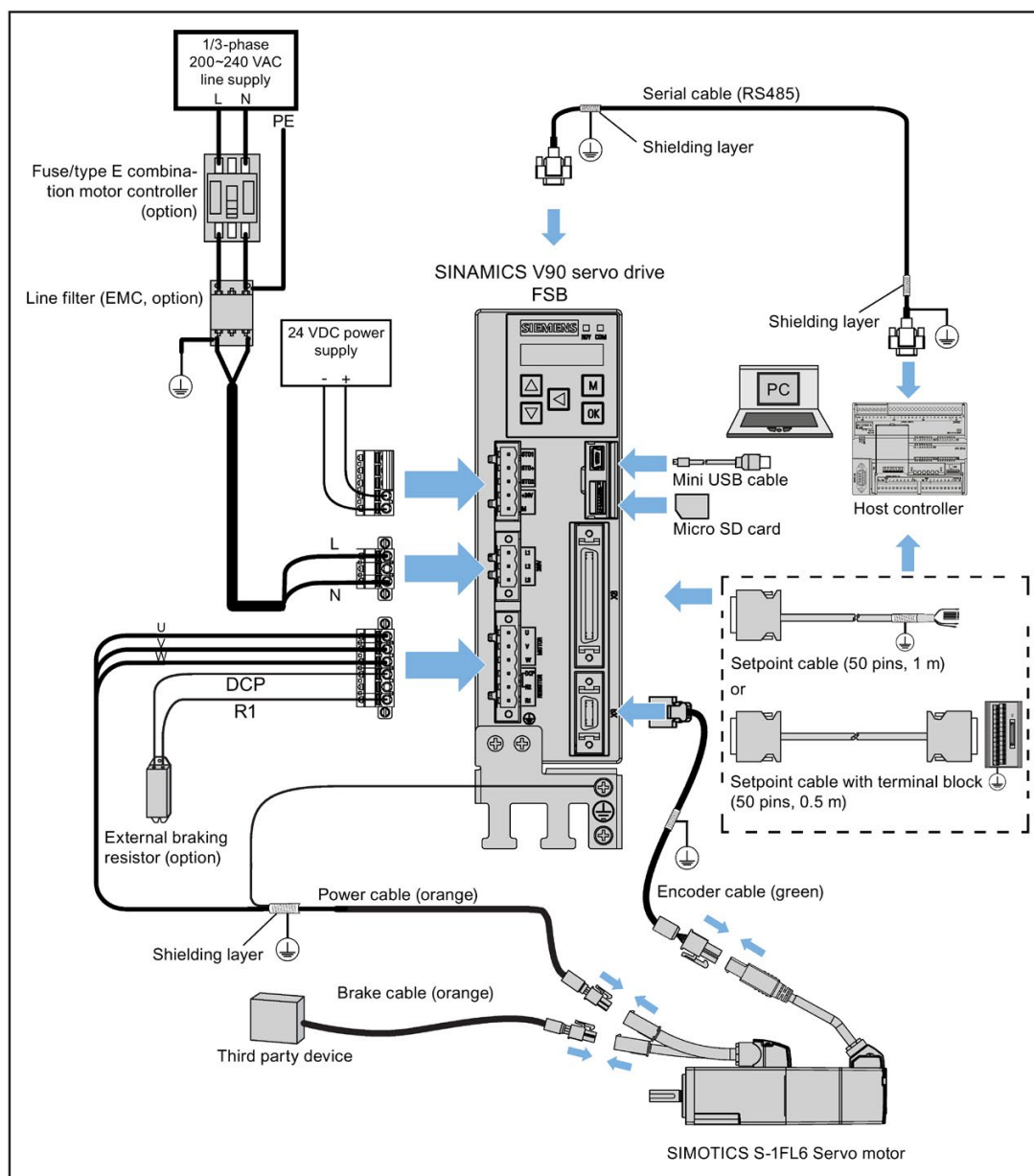

Connection diagram for FSD on the three phase power network:

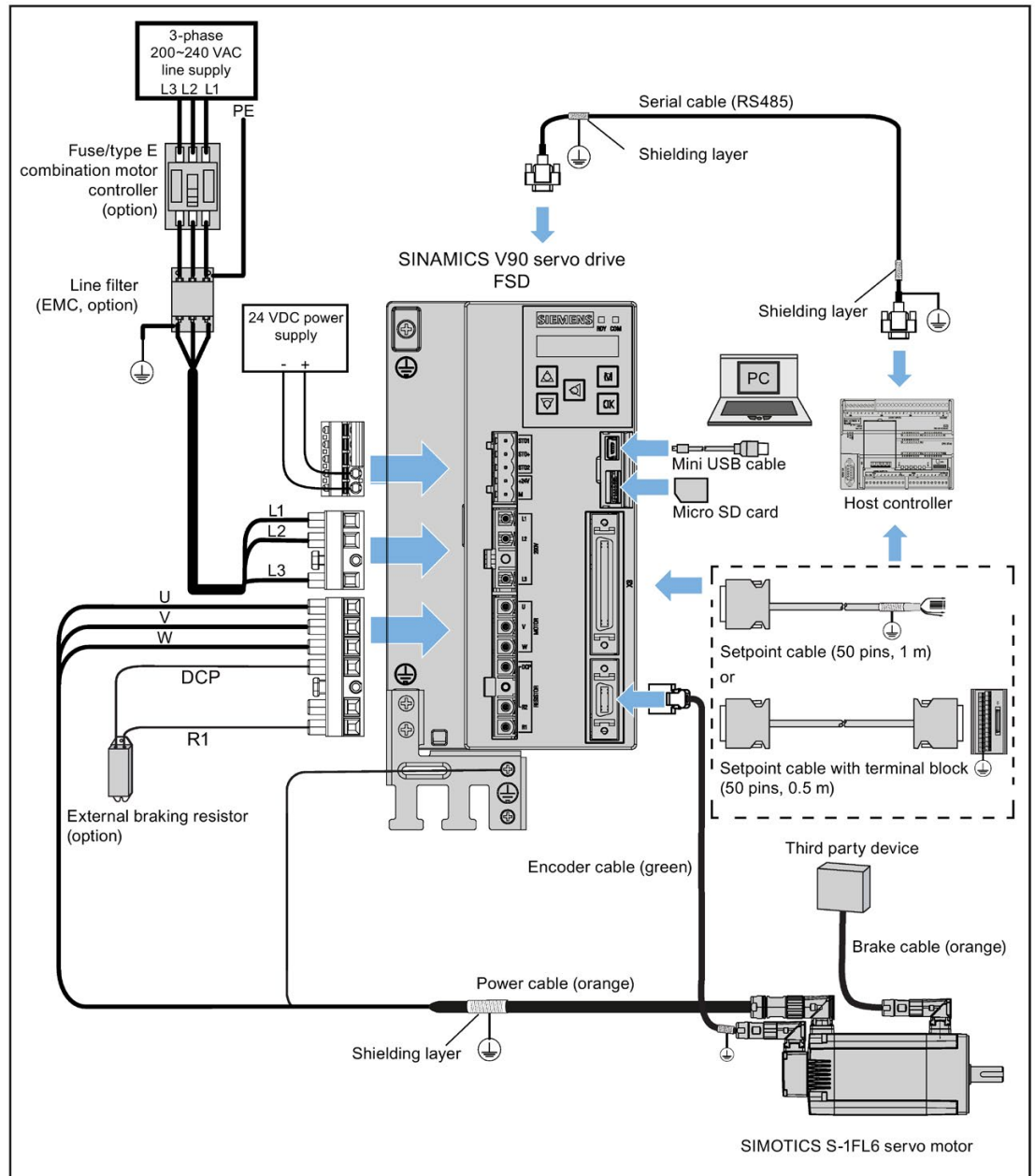

**SINAMICS V90 400 V variant**

Connection diagram for FSB on the three phase power network:

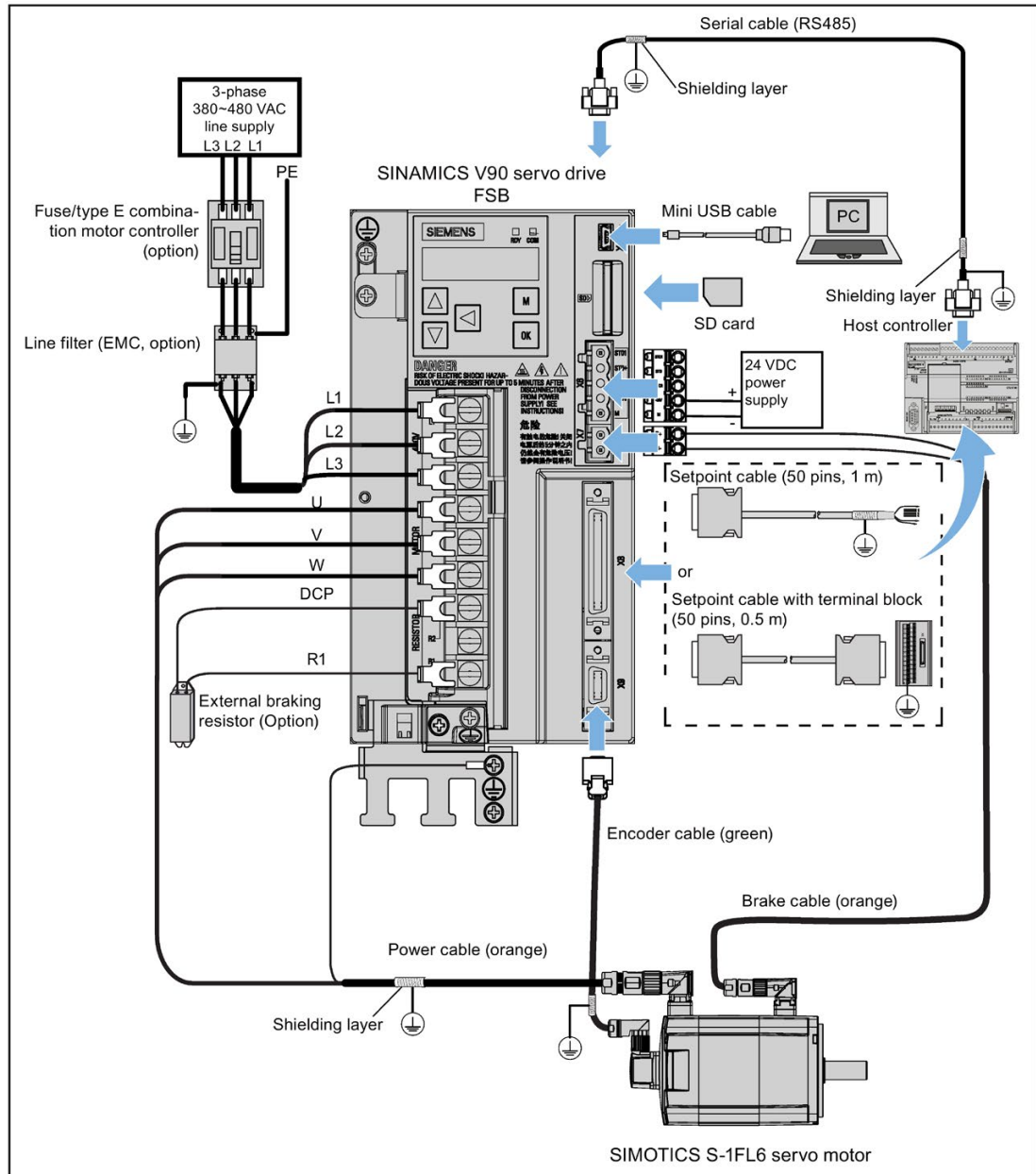

**⚠ WARNING**

**Electric shock due to touching PE connectors**

When the equipment is working, hazardous touch current can be present at the PE connectors; if touched, this can result in death or severe personal injury.

- Do not touch the PE connector during operation or within a certain period since power disconnection.



### **! WARNING**

#### **Electric shock and damage to property from improper connections**

Improper connections have high risks of electrical shock and short circuit, which will jeopardize personal safety and equipment.

- The drive must be directly connected with the motor. It is not permissible to connect a capacitor, inductor or filter between them.
- The line supply voltage must be within the allowable range (refer to the drive rating plate). Never connect the line supply cable to the motor terminals U, V, W or connect the motor power cable to the line input terminals L1, L2, L3.
- Never wire up the U, V, W terminals in an interchanged phase sequence.
- If the CE marking for cables is mandatory in some cases, the motor power cable, line supply cable and brake cable used must all be shielded cables.
- For terminal box connection, make sure that the clearances in air between non-insulated live parts are at least 5.5 mm.
- Cables connected may not come into contact with rotating mechanical parts.

### **NOTICE**

#### **Drive damage resulting from the short-circuiting between the shielding wire and the unused pin on the setpoint connector**

The shielding wire may inadvertently be short-circuited to the unused pin on the to-be-assembled setpoint connector. This can cause damage to the drive.

- Exercise caution when connecting the shielding cable to the setpoint connector.
- You can see the assembly method of encoder connector in Section "Assembly of cable terminals on the drive side (Page 373)" for reference.

### **Note**

#### **Interruptions of the internal protective bonding of the equipment caused by cable movement**

The interruptions of the internal protective bonding of the equipment may be caused by cable movement such as dragging cables.

- Do not drag cables when in operation.
- Make sure that you have performed appropriate protective measures for the protective bonding when moving cables.

### **Note**

#### **Failure to meet the EMC requirements resulting from failure to observe the wiring instruction**

Failure to meet the EMC requirements because you do not observe the wiring instruction.

- In order to meet **EMC** requirements, all cables must be shielded cables.
- Make sure that you connect the cable shields of shielded twisted-pair cables to the shielding plate or the hose clamp of the servo drive.

**Note**

**Low Voltage Directive complied**

Our products comply with EN61800-5-1: 2007 standards and Low Voltage Directive (Low Voltage Directive 2006/95/EC).

**Note**

For low inertia motors with shaft-heights of 20 mm, 30 mm and 40 mm, the encoder cable connectors may only be accessible to electrically skilled personnel.

**Note**

The mini-USB interface of the SINAMICS V90 is used for fast commissioning and diagnostics with SINAMICS V-ASSISTANT installed in the PC. Do not use it for long monitoring.

**Connecting the cable shields with the shielding plate**

To achieve EMC-compliant installation of the drive, use the shielding plate that is shipped with the drive to connect the cable shields. See the following example for steps to connect cable shields with the shielding plate:

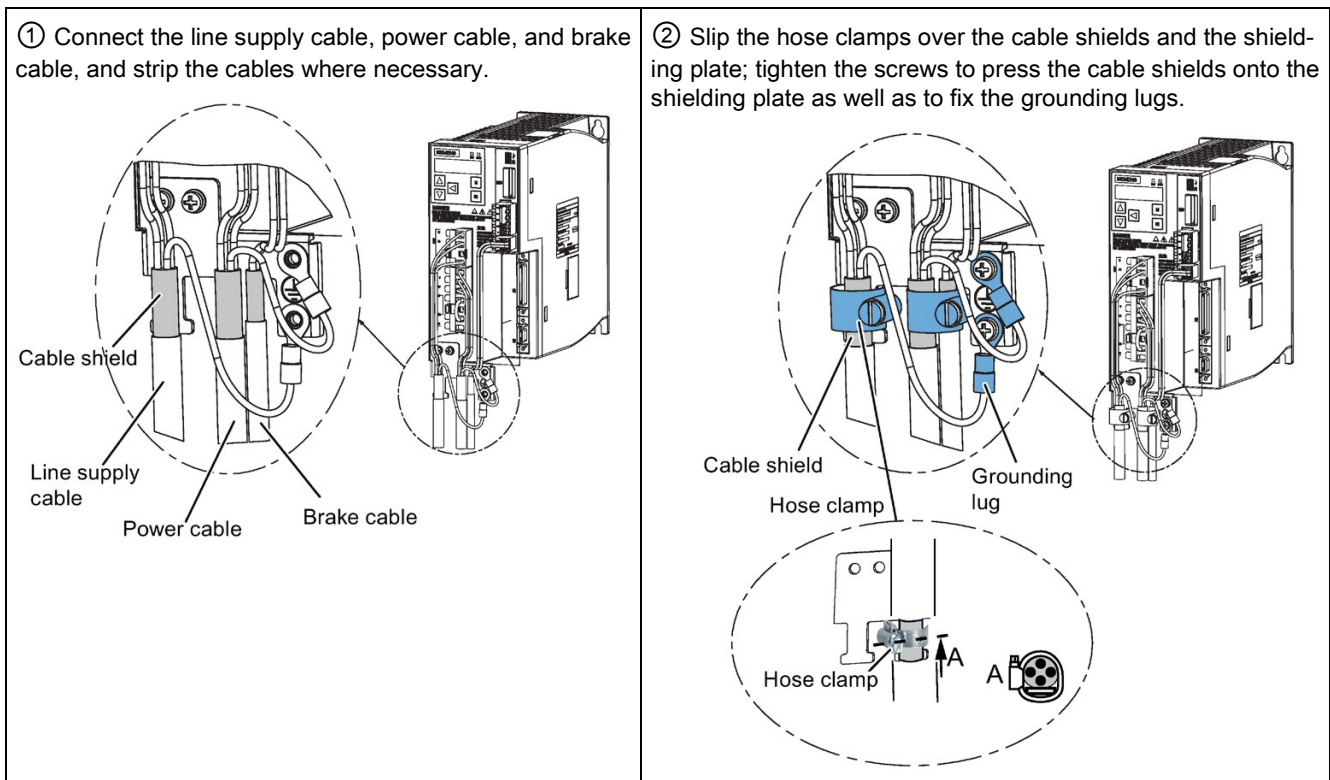



**! WARNING**

**Risk of electric shock and fire from a network with an excessively high impedance**

Excessively low short-circuit currents can lead to the protective devices not tripping or tripping too late, and so causing electric shock or a fire.

- In the case of a conductor-conductor or conductor-ground short-circuit, ensure that the short-circuit current at the point where the drive is connected to the line supply at least meets the minimum requirements for the response of the protective device used.
- You must use an additional residual-current device (RCD) if a conductor-ground short circuit does not reach the short-circuit current required for the protective device to respond. The required short-circuit current can be too low, especially for TT systems.



**! WARNING**

**Risk of electric shock and fire from a network with an impedance that is too low**

Excessively high short-circuit currents can lead to the protective devices not being able to interrupt these short-circuit currents and being destroyed, and so causing electric shock or a fire.

- Ensure that the uninfluenced short-circuit current at the line terminal of the drive does not exceed the breaking capacity (SCCR or I<sub>cc</sub>) of the protective device used.



**! WARNING**

**Death or severe personal injury from electrical shock**

The earth leakage current for the drive can be greater than AC 3.5 mA, which may cause death or severe personal injury due to electrical shock.

- A fixed earth connection is required to eliminate the dangerous leakage current. In addition, the minimum size of the protective earth conductor shall comply with the local safety regulations for high leakage current equipment.

### Adjusting cable directions from the motor side

For some low inertia motors and all high inertia motors, you can adjust the direction of the power cable, encoder cable, or brake cable from the motor side to facilitate cable connection.

The following illustrations take high inertia motors with the incremental encoder for example to show how to adjust the cable directions.

**Low inertia motors with a shaft height of 50 mm and high inertia motors with straight connectors**

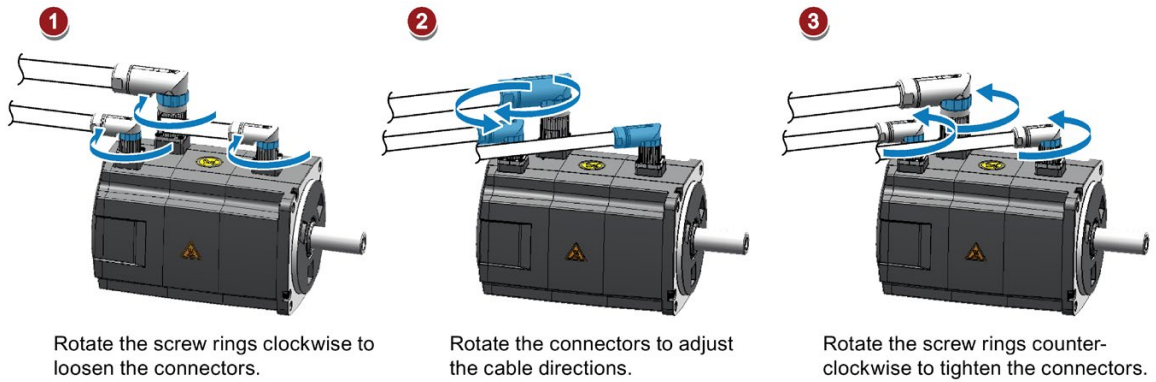

**Note**  
**Rotating the connectors**

After connecting the cable to the motor, you can rotate the incremental encoder connector within 270° and rotate the absolute encoder connector within 180°. For other connectors, you can rotate them within 360°.

**High inertia motors with angular connectors**

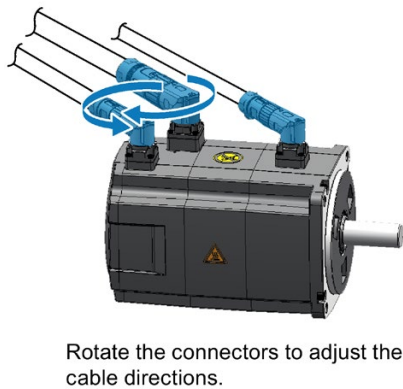

**Note**  
**Rotating the connectors**

For motors with angular connectors, you can rotate all the connectors within 310° except for the absolute encoder connector which can be rotated only within 180°.

**Note**  
For an absolute encoder cable on a high inertia motor with angular connectors, adjust its direction just the same as you adjust the cable directions on a high inertia motor with straight connectors mentioned above.



## 4.2 Main circuit wiring

### 4.2.1 Line supply - L1, L2, L3

Signal	Description
<b>200 V variant</b>	
L1	Line phase L1
L2	Line phase L2
L3	Line phase L3
Recommended minimum cable cross-section: When used on the single phase power network: FSA: 0.75 mm <sup>2</sup> FSB: 0.52 mm <sup>2</sup> FSC: 1.31 mm <sup>2</sup> When used on the three phase power network: FSA: 0.75 mm <sup>2</sup> FSB: 0.33 mm <sup>2</sup> FSC: 0.52 mm <sup>2</sup> FSD (1 kW): 0.82 mm <sup>2</sup> FSD (1.5 kW to 2 kW): 2.08 mm <sup>2</sup>	
<b>400 V variant</b>	
L1	Line phase L1
L2	Line phase L2
L3	Line phase L3
Recommended minimum cable cross-section: FSAA and FSA: 1.5 mm <sup>2</sup> FSB and FSC: 2.5 mm <sup>2</sup>	

**Note**

For 200 V variant servo drive, when using the FSA, FSB and FSC on the single phase power network, you can connect the power supply to any two connectors of L1, L2, and L3.

### Assembling the line supply cable terminals

The procedure of assembling a line supply cable terminal is the same as that for a power cable terminal on the drive side.

For more information, see Section "Assembly of cable terminals on the drive side (Page 373)".

### Attaching the line supply cable

**⚠ CAUTION**

**Risk of injury due to improper cable connection**

When attaching the line supply cable to a line supply connector that has not been fixed on the drive, you can injure your fingers.

- Make sure you first assemble the line supply connector to the drive and tighten the fixing screws on the connector, and then attach the cable to the connector.

#### 200 V variant

- For FSA and FSB

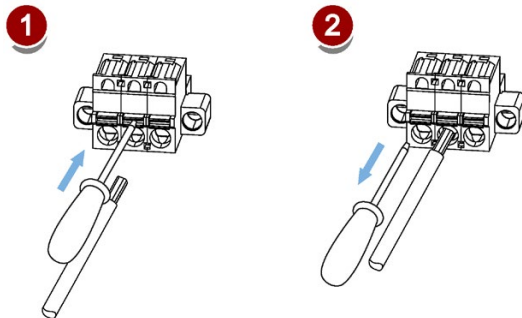

- For FSC and FSD

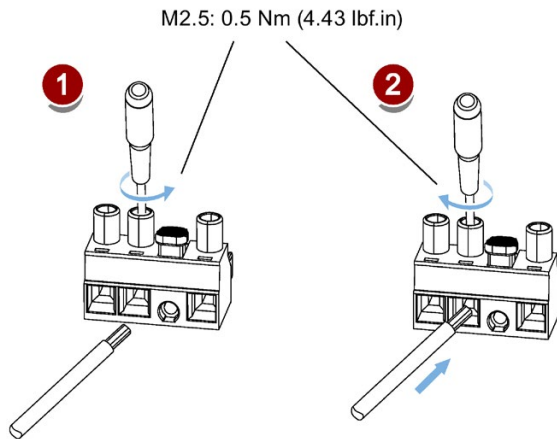

#### 400 V variant

- For FSAA and FSA

You can attach the line supply cable with the same method for 200 V variant drives of frame sizes FSC and FSD.

- For FSB and FSC



The FSB and FSC servo drives are equipped with barrier terminals for line supply connection. You can fix the line supply cable on the servo drives by using the M4 screws with a tightening torque of 2.25 Nm (19.91 lbf.in).

## 4.2.2 Motor power - U, V, W

### Motor output - drive side

Signal	Description
<b>200 V variant</b>	
U	Motor phase U
V	Motor phase V
W	Motor phase W
Recommended minimum cable cross-section: FSA and FSB: 0.75 mm <sup>2</sup> FSC and FSD (1 kW): 0.75 mm <sup>2</sup> FSD (1.5 kW to 2 kW): 2.5 mm <sup>2</sup>	
<b>400 V variant</b>	
U	Motor phase U
V	Motor phase V
W	Motor phase W
Recommended minimum cable cross-section: FSAA and FSA: 1.5 mm <sup>2</sup> FSB and FSC: 2.5 mm <sup>2</sup>	

### Power connector - motor side

Illustration	Pin No.	Signal	Color	Description
<b>Low inertia motor, shaft-height: 20 mm, 30 mm, and 40 mm</b>				
	1	U	Black	Phase U
	2	V	Black	Phase V
	3	W	Black	Phase W
	4	PE	Yellow-green	Protective earthing
<b>Low inertia motor, shaft-height: 50 mm</b> <b>High inertia motor, shaft-height: 45 mm, 60 mm, and 90 mm</b>				
Straight connectors:   Angular connectors: 	1	U	Black	Phase U
	2	V	Black	Phase V
	3	W	Black	Phase W
	4/⊥	PE	Yellow-green	Protective earthing

Wiring

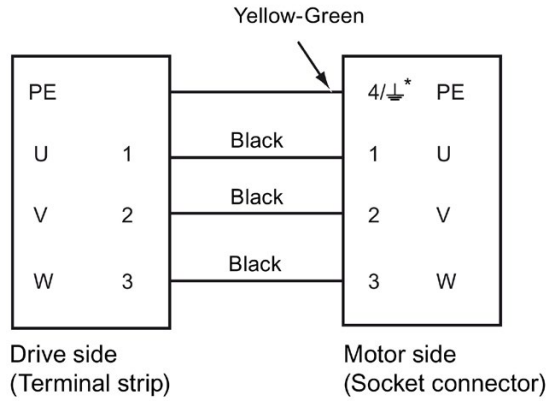

- \* 4: high inertia motors with straight connectors and all low inertia motors
- ⊥: high inertia motors with angular connectors

Attaching the motor power cable

**⚠ CAUTION**

**Risk of injury due to improper cable connection**

When attaching the motor power cable to a motor power connector that has not been fixed on the drive, you can injure your fingers.

- Make sure you first assemble the motor power connector to the drive and tighten the fixing screw on the connector, and then attach the cable to the connector.

200 V variant

- FSA and FSB

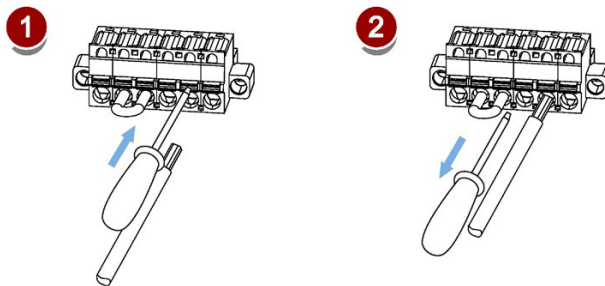

- FSC and FSD

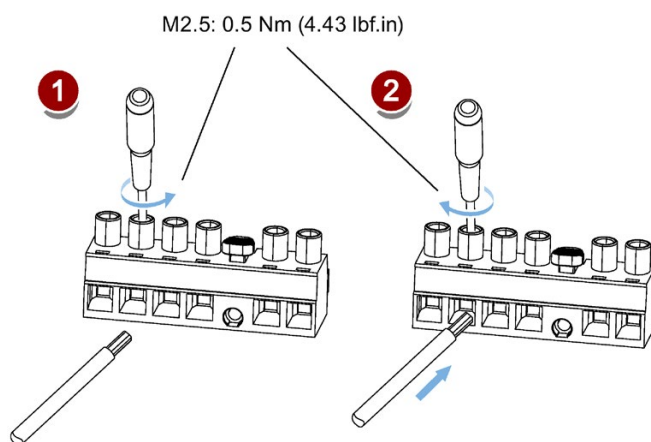

#### 400 V variant

- For FSAA and FSA

You can attach the motor power cable with the same method for 200 V variant drives of frame sizes FSC and FSD.

- For FSB and FSC

The FSB and FSC servo drives are equipped with barrier terminals for motor power connection. You can fix the motor power cable on the servo drives by using the M4 screws with a tightening torque of 2.25 Nm (19.91 lbf.in).

## 4.3 Control/status interface - X8

The pins with an asterisk (\*) have been redefined in the table below, wherein DO4(+/-) to DO6(+/-) are used for the servo drive to support the wiring of **both** the NPN and the PNP types.

---

### Note





























The pin definition updates are applicable only when the FS (function state) version is as follows:

- V90 200 V: FS02 and the later
- V90 400 V: FS04 and the later

Refer to the rating plate on the drive housing for the FS version of a SINAMICS V90 servo drive.

---

Pin No.	Signal	Wire color on the set-point cable exposed side	Description
Type: 50-pin MDR socket			
<b>Pulse train inputs (PTI)/Pulse train encoder outputs (PTO)</b>			
1, 2, 26, 27: Position setpoint with pulse train input High-speed 5 V differential pulse train input (RS485) Maximum frequency: 1MHz Signal transmission of this channel has better noise immunity			
1	PTIA_D+	Gray-Pink	High-speed 5 V differential pulse train input A (+)
2	PTIA_D-	Red-Bule	High-speed 5 V differential pulse train input A (-)
26	PTIB_D+	White-Black	High-speed 5 V differential pulse train input B (+)
27	PTIB_D-	Brown-Black	High-speed 5 V differential pulse train input B (-)
36, 37, 38, 39: Position setpoint with pulse train input 24 V single end pulse train input Maximum frequency: 200 kHz			
36	PTIA_24P	Green-Blue	24 V pulse train input A, positive
37	PTIA_24M	Yellow-Blue	24 V pulse train input A, ground
38	PTIB_24P	Green-Black	24 V pulse train input B, positive
39	PTIB_24M	Yellow-Black	24 V pulse train input B, ground
15, 16, 40, 41: Encoder emulation pulse output with high-speed 5 V differential signals (A+/A-, B+/B-)			
15	PTOA+	White-Yellow	High-speed 5 V differential pulse train encoder output A (+)
16	PTOA-	Yellow-Brown	High-speed 5 V differential pulse train encoder output A (-)
40	PTOB+	Gray-Blue	High-speed 5 V differential pulse train encoder output B (+)
41	PTOB-	Pink-Blue	High-speed 5 V differential pulse train encoder output B (-)

Pin No.	Signal	Wire color on the set-point cable exposed side	Description
17, 25 *: Encoder Zero phase pulse output and reference ground (with open collector)			
17	PTOZ (OC)	 White-Gray	Pulse train encoder output Z signal (open collector output)
25 *	PTOZ_M (OC)	 Gray-Green	Pulse train output Z signal reference ground (open collector output)
42, 43: Encoder Zero phase pulse output with high-speed 5 V differential signals			
42	PTOZ+	 Gray-Red	High-speed 5 V differential pulse train encoder output Z (+)
43	PTOZ-	 Pink-Red	High-speed 5 V differential pulse train encoder output Z (-)
24 *: PTO and PTI_D reference ground			
24 *	M	 Brown-Red	PTO and PTI_D reference ground
<b>Digital inputs/outputs</b>			
3	DI_COM	 Green	Common terminal for digital inputs
4	DI_COM	 Yellow	Common terminal for digital inputs
5	DI1	 Gray	Digital input 1
6	DI2	 Pink	Digital input 2
7	DI3	 Blue	Digital input 3
8	DI4	 Red	Digital input 4
9	DI5	 Black	Digital input 5
10	DI6	 Violet	Digital input 6
11	DI7	 White	Digital input 7
12	DI8	 Brown	Digital input 8
13	DI9	 White-Green	Digital input 9
14	DI10	 Brown-Green	Digital input 10
23	Brake	 White-Red	Motor holding brake control signal (for SINAMICS V90 200 V variant only)
28	P24V_DO	 Yellow-Gray	External 24 V supply for digital outputs
29 *	DO4+	 Green	Digital output 4+
30	DO1	 Yellow	Digital output 1
31	DO2	 Gray	Digital output 2
32	DO3	 Pink	Digital output 3
33 *	DO4-	 Pink-Green	Digital output 4-
34 *	DO5+	 Yellow-Pink	Digital output 5+
35 *	DO6+	 Green-Red	Digital output 6+
44 *	DO5-	 Yellow-Red	Digital output 5-
49 *	DO6-	 White	Digital output 6-
50	MEXT_DO	 Brown	External 24 V ground for digital outputs

Pin No.	Signal	Wire color on the set-point cable exposed side	Description
<b>Analog inputs/outputs</b>			
18	P12AI	 Gray-Brown	12 V power output for analog input
19	AI1+	 White-Pink	Analog input channel 1, positive
20	AI1-	 Pink-Brown	Analog input channel 1, negative
21	AI2+	 White-Blue	Analog input channel 2, positive
22	AI2-	 Brown-Blue	Analog input channel 2, negative
45	AO_M	 Gray-Black	Analog output ground
46	AO1	 Pink-Black	Analog output channel 1
47	AO_M	 Blue-Black	Analog output ground
48	AO2	 Red-Black	Analog output channel 2

Refer to the following table for the original definitions of the above pins with an asterisk (\*), wherein DO4 to DO6 are used for the servo drive to support the wiring of **only** the NPN type.

**Note**

The original pin definitions are applicable only when the FS version is as follows:

- V90 200 V: FS01
- V90 400 V: FS03 and the earlier

Refer to the rating plate on the drive housing for the FS version of a SINAMICS V90 servo drive.

Pin No.	Signal	Description
24	-	Reserved
25	-	Reserved
29	P24V_DO	External 24 V supply for digital outputs
33	DO4	Digital output 4
34	DO5	Digital output 5
35	DO6	Digital output 6
44	-	Reserved
49	MEXT_DO	External 24 V ground for digital outputs

**4.3.1 Digital inputs/outputs (DIs/DOs)**

SINAMICS V90 supports free assignment of signals to the following digital input and output terminals depending on the control mode selected:

DI1 to DI8 -- Assignable with parameters p29301 to p29308

DO1 to DO6 -- Assignable with parameters p29330 to p29335

Exception: DI9 and DI10

DI9 is permanently assigned with the signal EMGS (quick stop) and DI10 is permanently assigned with the signal C-MODE (change mode).



For detailed information about default DI/DO signal assignments, see the table below:

Pin No.	Digital inputs/outputs	Parameters	Default signals/values			
			Index 0 (PTI)	Index 1 (IPos)	Index 2 (S)	Index 3 (T)
5	DI1	p29301	1 (SON)	1 (SON)	1 (SON)	1 (SON)
6	DI2	p29302	2 (RESET)	2 (RESET)	2 (RESET)	2 (RESET)
7	DI3	p29303	3 (CWL)	3 (CWL)	3 (CWL)	3 (CWL)
8	DI4	p29304	4 (CCWL)	4 (CCWL)	4 (CCWL)	4 (CCWL)
9	DI5	p29305	5 (G-CHANGE)	5 (G-CHANGE)	12 (CWE)	12 (CWE)
10	DI6	p29306	6 (P-TRG)	6 (P-TRG)	13 (CCWE)	13 (CCWE)
11	DI7	p29307	7 (CLR)	21 (POS1)	15 (SPD1)	18 (TSET)
12	DI8	p29308	10 (TLIM1)	22 (POS2)	16 (SPD2)	19 (SLIM1)
30	DO1	p29330	1 (RDY)			
31	DO2	p29331	2 (FAULT)			
32	DO3	p29332	3 (INP)			
29/33	DO4	p29333	5 (SPDR)			
34/44	DO5	p29334	6 (TLR)			
35/49	DO6	p29335	8 (MBR)			

#### Note

The selected DI signal will respond with a delay time of 8 ms to 16 ms.

#### Note

##### DO signal inverse

The logics of digital output signals DO1 to DO6 can be inverted. You can inverse the logics of DO1 to DO6 by setting the bit 0 to bit 5 of parameter p0748.

#### 4.3.1.1 DIs

You can assign a maximum of 28 internal digital input signals to the SINAMICS V90 servo drive. For detailed information about these signals, see the table below:

No.	Name	Type	Description	Control mode			
				PTI	IPos	S	T
1	SON	Edge 0→1 1→0	Servo-on <ul style="list-style-type: none"> <li>0→1: powers on power circuit and makes servo drive ready to operate.</li> <li>1→0: motor ramps down (OFF1) in PTI, IPos, and S modes; motor coasts down (OFF2) in T mode.</li> </ul>	✓	✓	✓	✓
2	RESET	Edge 0→1	Reset alarms <ul style="list-style-type: none"> <li>0→1: Reset alarms</li> </ul>	✓	✓	✓	✓

No.	Name	Type	Description	Control mode			
				PTI	IPos	S	T
3	CWL	Edge 1→0	Clockwise over-travel limit (positive limit) <ul style="list-style-type: none"> <li>1 = condition for operation</li> <li>1→0: quick stop (OFF3)</li> </ul>	✓	✓	✓	✓
4	CCWL	Edge 1→0	Counter-clockwise over-travel limit (negative limit) <ul style="list-style-type: none"> <li>1 = condition for operation</li> <li>1→0: quick stop (OFF3)</li> </ul>	✓	✓	✓	✓
5	G-CHANGE	Level	Gain change between the first and the second gain parameter set. <ul style="list-style-type: none"> <li>0: the first gain parameter set</li> <li>1: the second gain parameter set</li> </ul>	✓	✓	✓	X
6	P-TRG	Level Edge 0→1	In PTI mode: pulse allowable/inhibit. <ul style="list-style-type: none"> <li>0: operation with pulse train setpoint is possible</li> <li>1: inhibit the pulse train setpoint</li> </ul> In IPos mode: position trigger <ul style="list-style-type: none"> <li>0→1: starts positioning of selected fixed position setpoint</li> </ul> <b>Note:</b> P-TRG in PTI mode is reserved for future use	✓	✓	X	X
7	CLR	Level	Clear position control droop pulses. <ul style="list-style-type: none"> <li>0: not clear</li> <li>1: clear the droop pulses based on the selected clear mode by p29242</li> </ul>	✓	X	X	X
8	EGEAR1	Level	Electronic gear.	✓	X	X	X
9	EGEAR2	Level	A combination of the signals EGEAR1 and EGEAR2 can select four electronic gear ratios. EGEAR2 : EGEAR1 <ul style="list-style-type: none"> <li>0 : 0: electronic gear ratios 1</li> <li>0 : 1: electronic gear ratios 2</li> <li>1 : 0: electronic gear ratios 3</li> <li>1 : 1: electronic gear ratios 4</li> </ul>	✓	X	X	X
10	TLIM1	Level	Torque limit selection.	✓	✓	✓	X
11	TLIM2	Level	A combination of TLIM1 and TLIM2 can select four torque limit sources (one external torque limit, three internal torque limits). TLIM2 : TLIM1 <ul style="list-style-type: none"> <li>0 : 0: internal torque limit 1</li> <li>0 : 1: external torque limit (analog input 2)</li> <li>1 : 0: internal torque limit 2</li> <li>1 : 1: internal torque limit 3</li> </ul>	✓	✓	✓	X

No.	Name	Type	Description	Control mode			
				PTI	IPos	S	T
12	CWE	Level	Enable clockwise rotations. <ul style="list-style-type: none"> <li>1: Enable clockwise rotation, ramp up</li> <li>0: Disable clockwise rotation, ramp down</li> </ul>	X	X	✓	✓
13	CCWE	Level	Enable counter-clockwise rotations. <ul style="list-style-type: none"> <li>1: Enable counter-clockwise rotation, ramp down</li> <li>0: Disable counter-clockwise rotation, ramp up</li> </ul>	X	X	✓	✓
14	ZSCLAMP	Level	Zero speed clamps. <ul style="list-style-type: none"> <li>1 = when the motor speed setpoint is an analog signal and lower than the threshold level (p29075), the motor is clamped.</li> <li>0 = no action</li> </ul>	X	X	✓	X
15	SPD1	Level	Select speed mode: fixed speed setpoint.	X	X	✓	X
16	SPD2	Level	A combination of the signals SPD1, SPD2 and SPD3 can select eight speed setpoint sources (one external speed setpoint, seven fixed speed setpoints). SPD3 : SPD2 : SPD1				
17	SPD3	Level					
			<ul style="list-style-type: none"> <li>0 : 0 : 0: external analog speed setpoint</li> <li>0 : 0 : 1: fixed speed setpoint 1</li> <li>0 : 1 : 0: fixed speed setpoint 2</li> <li>0 : 1 : 1: fixed speed setpoint 3</li> <li>1 : 0 : 0: fixed speed setpoint 4</li> <li>1 : 0 : 1: fixed speed setpoint 5</li> <li>1 : 1 : 0: fixed speed setpoint 6</li> <li>1 : 1 : 1: fixed speed setpoint 7</li> </ul>				
18	TSET	Level	Torque setpoint selection. This signal can select two torque setpoint sources (one external torque setpoint, one fixed torque setpoint). <ul style="list-style-type: none"> <li>0: external torque setpoint (analog input 2)</li> <li>1: fixed torque setpoint</li> </ul>	X	X	X	✓
19	SLIM1	Level	Speed limit selection.	✓	✓	✓	✓
20	SLIM2	Level	A combination of SLIM1 to SLIM2 can select four speed limit sources (one external speed limit, three internal speed limits). SLIM2 : SLIM1 <ul style="list-style-type: none"> <li>0 : 0: internal speed limit 1</li> <li>0 : 1: external speed limit (analog input 1)</li> <li>1 : 0: internal speed limit 2</li> <li>1 : 1: internal speed limit 3</li> </ul>				

No.	Name	Type	Description	Control mode			
				PTI	IPos	S	T
21	POS1	Level	Select position setpoint.	X	✓	X	X
22	POS2	Level	A combination of the signals POS1 to POS3 can select eight fixed position setpoint sources. POS3 : POS2 : POS1 <ul style="list-style-type: none"> <li>0 : 0 : 0: fixed position setpoint 1</li> <li>0 : 0 : 1: fixed position setpoint 2</li> <li>0 : 1 : 0: fixed position setpoint 3</li> <li>0 : 1 : 1: fixed position setpoint 4</li> <li>1 : 0 : 0: fixed position setpoint 5</li> <li>1 : 0 : 1: fixed position setpoint 6</li> <li>1 : 1 : 0: fixed position setpoint 7</li> <li>1 : 1 : 1: fixed position setpoint 8</li> </ul>	X	✓	X	X
23	POS3	Level					
24	REF	Edge 0→1	Set reference point with digital input or reference cam input for reference approaching mode. <ul style="list-style-type: none"> <li>0→1: reference input</li> </ul>	X	✓	X	X
25	SREF	Edge 0→1	The reference approach will be started with the signal SREF. <ul style="list-style-type: none"> <li>0→1 start reference approach</li> </ul>	X	✓	X	X
26	STEPF	Edge 0→1	Step forward to the next fixed position setpoint. <ul style="list-style-type: none"> <li>0→1 start step action</li> </ul>	X	✓	X	X
27	STEPB	Edge 0→1	Step backward to the previous fixed position setpoint. <ul style="list-style-type: none"> <li>0→1 start step action</li> </ul>	X	✓	X	X
28	STEPH	Edge 0→1	Step to the fixed position setpoint 1. <ul style="list-style-type: none"> <li>0→1 start step action</li> </ul>	X	✓	X	X

**Note**

When working in the torque control mode, the torque setpoint equals to 0 if CWE and CCWE are at the same status. For more information, please refer to section Direction and stop (Page 234).

**Note****Invalid circumstances for DI signals**

When SINAMICS V-ASSISTANT is communicating with the drive or you are operating the drive on SINAMICS V-ASSISTANT, some DI signals are invalid:

- During referencing via SINAMICS V-ASSISTANT, DI signal SREF is invalid.
- During a trial run test, DI signal SON is invalid; meanwhile, DI7 and DI8 are occupied by SINAMICS V-ASSISTANT.

## Direct signal map

Force the following six signals to logical "1" with parameter p29300 (P\_DI\_Mat):

- SON
- CWL
- CCWL
- TLIM1
- SPD1
- TSET
- EMGS

The definition for p29300 is as follows:

Bit 6	Bit 5	Bit 4	Bit 3	Bit 2	Bit 1	Bit 0
EMGS	TSET	SPD1	TLIM1	CCWL	CWL	SON

For example, if you set p29300 = 1 to force the signal SON to a logical high signal, DI1 can then be assigned to other desired signals.

---

### Note

The parameter p29300 has higher priority than the DIs.

The bit 6 of p29300 is used for quick stop. You are not allowed to modify it when the drive is in "S ON" state.

---

## Wiring

The digital inputs support both PNP and NPN types of wirings. You can find detailed information from the following diagrams:

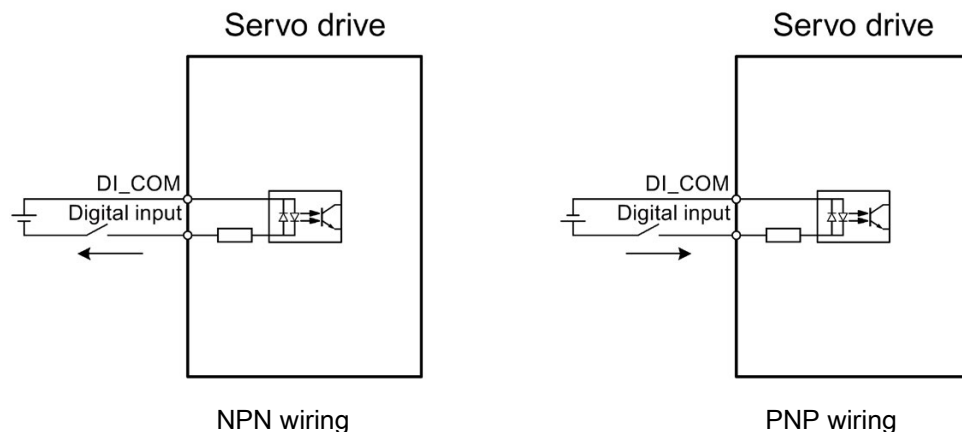

## 4.3.1.2 DOs

You can assign a maximum of 15 internal digital output signals to the SINAMICS V90 servo drive. For detailed information about these signals, see the table below:

No.	Name	Descriptions	Control mode			
			PTI	IPos	S	T
1	RDY	Servo ready <ul style="list-style-type: none"> <li>1: the drive is ready.</li> <li>0: the drive is not ready (a fault occurs or the enable signal is missing).</li> </ul>	✓	✓	✓	✓
2	FAULT	Fault <ul style="list-style-type: none"> <li>1: in the fault state.</li> <li>0: no fault.</li> </ul>	✓	✓	✓	✓
3	INP	In-position signal <ul style="list-style-type: none"> <li>1: the number of droop pulses is in the preset in-position range (parameter p2544).</li> <li>0: the number of droop pulses is beyond the preset in-position range.</li> </ul>	✓	✓	X	X
4	ZSP	Zero speed detection <ul style="list-style-type: none"> <li>1: motor speed <math>\leq</math> zero speed (can be set with parameter p2161).</li> <li>0: motor speed <math>&gt;</math> zero speed + hysteresis (10 rpm).</li> </ul>	✓	✓	✓	✓
5	SPDR	Speed reached <ul style="list-style-type: none"> <li>1: the actual motor speed has nearly (internal hysteresis 10 rpm) reached the speed of the internal speed command or analog speed command. The speed approaching range can be set via parameter p29078.</li> <li>0: the speed difference between the speed setpoint and the actual speed is larger than the internal hysteresis.</li> </ul>	X	X	✓	X
6	TLR	Torque limit reached <ul style="list-style-type: none"> <li>1: the generated torque has nearly (internal hysteresis) reached the value of the positive torque limit, negative torque limit or analog torque limit.</li> <li>0: the generated torque has not reached any torque limit.</li> </ul>	✓	✓	✓	X
7	SPLR	Speed limit reached <ul style="list-style-type: none"> <li>1: the speed has nearly (internal hysteresis 10 rpm) reached the speed limit.</li> <li>0: the speed has not reached the speed limit.</li> </ul>	✓	✓	✓	X

No.	Name	Descriptions	Control mode			
			PTI	IPos	S	T
8	MBR	Motor holding brake <ul style="list-style-type: none"> <li>1: the motor holding brake is engaged.</li> <li>0: the motor holding brake is released.</li> </ul> <b>Note:</b> MBR is only a status signal because the control and the power supply of the motor holding brake are realized with separate terminals.	✓	✓	✓	✓
9	OLL	Overload level reached <ul style="list-style-type: none"> <li>1: the motor has reached the parameterizable output overload level (p29080 in % of the rated torque; default: 100%; max: 300%).</li> <li>0: the motor has not reached the overload level.</li> </ul>	✓	✓	✓	✓
10	WARNING1	Warning 1 condition satisfied <ul style="list-style-type: none"> <li>1: the parameterizable warning 1 condition has been satisfied.</li> <li>0: the parameterizable warning 1 condition has not been satisfied.</li> </ul> See the note below on warning condition settings.	✓	✓	✓	✓
11	WARNING2	Warning 2 condition satisfied <ul style="list-style-type: none"> <li>1: the parameterizable warning 2 condition has been satisfied.</li> <li>0: the parameterizable warning 2 condition has not been satisfied.</li> </ul> See the note below on warning condition settings.	✓	✓	✓	✓
12	REFOK	Referenced <ul style="list-style-type: none"> <li>1: referenced.</li> <li>0: not referenced.</li> </ul>	X	✓	X	X
13	CM_STA	Current control mode <ul style="list-style-type: none"> <li>1: the second mode in five compound control modes (PTI/S, IPos/S, PTI/T, IPos/T, S/T).</li> <li>0: the first mode in five compound control modes or four basic modes (PTI, IPos, S, T).</li> </ul>	✓	✓	✓	✓
14	RDY_ON	Ready for servo on <ul style="list-style-type: none"> <li>1: the drive is ready for servo on.</li> <li>0: the drive is not ready for servo on (a fault occurs or the main power supply is missing).</li> </ul> <b>Note:</b> after the drive is in "S ON" state, the signal remains at high level (1) unless the above abnormal cases happen.	✓	✓	✓	✓
15	STO_EP	STO active <ul style="list-style-type: none"> <li>1: the enable signal is missing, indicating that STO is active.</li> <li>0: the enable signal is available, indicating that STO is inactive.</li> </ul> <b>Note:</b> STO_EP is only a status signal for STO input terminals but not a safe DO for the Safety Integrated function.	✓	✓	✓	✓

### Assigning warning signals to digital outputs

You can assign two groups of warning signals to digital outputs with parameters p29340 (first group of warning signals active) and p29341 (second group of warning signals active).

Setting (p29340/p29341)	Warning conditions
1	Overload protection: load factor is 85% of or above the motor utilization.
2	Holding brake power overload warning: threshold p29005 has been reached.
3	Fan alarm: fan has stopped for 1 second or longer.
4	Encoder alarm.
5	Motor overheat: motor has reached 85% of the maximum allowed motor temperature.
6	Lifetime detection: the life expectancy of the capacity or the fan is shorter than the specified time.

#### Note

If the warning condition(s) assigned to p29340 occur, WARNING1 becomes ON.

If the warning condition(s) assigned to p29341 occur, WARNING2 becomes ON.

### Wiring

The digital outputs 1 to 3 only support the wiring of the NPN type as illustrated below:

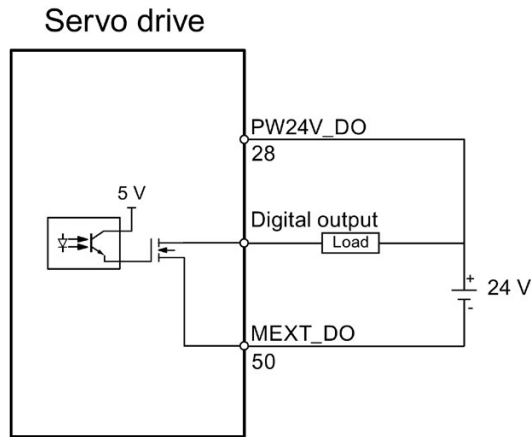



The digital outputs 4 to 6 support the wiring of both the NPN and the PNP types as illustrated below:

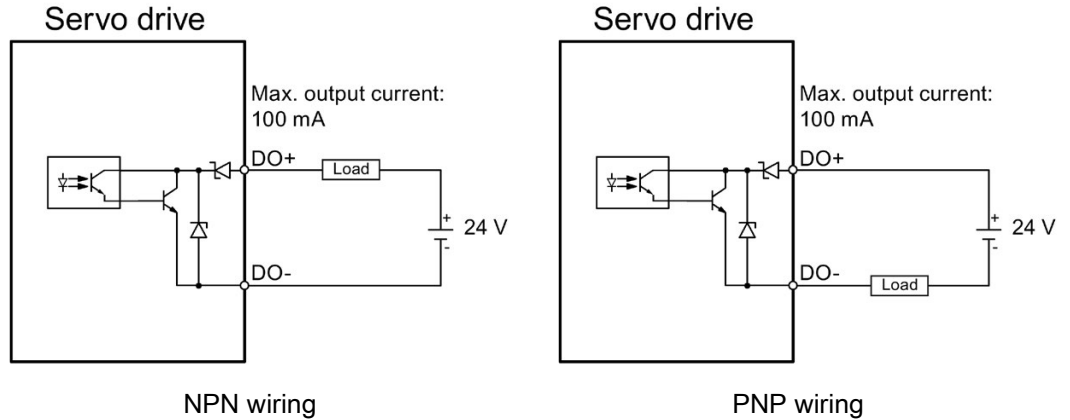

## 4.3.2 Pulse train inputs/encoder outputs (PTIs/PTOs)

### 4.3.2.1 PTIs

Two channels of pulse train input are available for the SINAMICS V90 servo drive:

- 24 V single end pulse train input
- High-speed 5 V differential pulse train input (RS485)

When using the 24 V single end PTI:

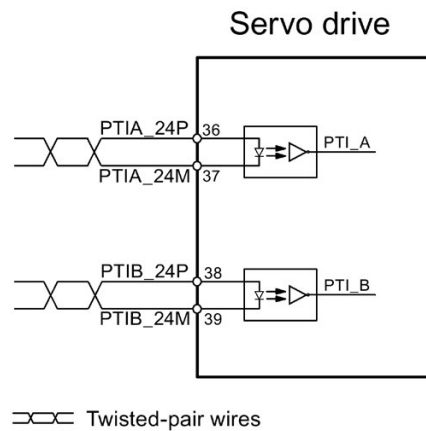

When using the 5 V differential PTI:

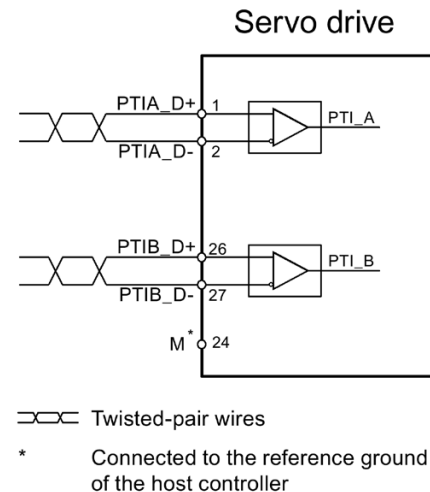

**Note**

Only one channel can be used. The 24 V single end PTI is the factory setting of the SINAMICS V90 servo drives.

When you choose to use the high-speed 5 V differential PTI (RS485), you must change the value of parameter p29014 from 1 to 0. Refer to "Selecting a setpoint pulse train input channel (Page 192)".

**4.3.2.2 PTOs**

High-speed 5 V differential signals (A+/A-, B+/B-, Z+/Z-) and open collector (zero pulse) are supported.

**Wirings**

When not using the open collector:

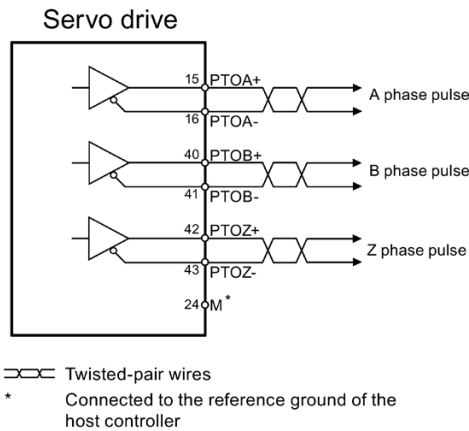

When using the open collector:

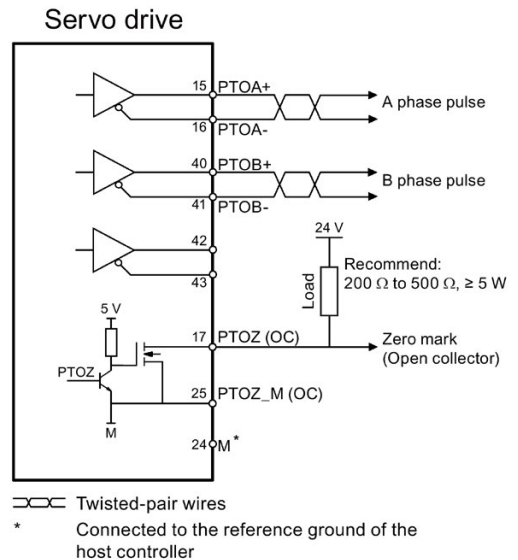

### 4.3.3 Analog inputs/outputs (AIs/AOs)

#### 4.3.3.1 AIs

SINAMICS V90 has two analog input terminals. The input voltage at each analog input varies with control modes.

Pin No.	Analog input	Input voltage	Control mode	Function
19, 20	Analog input 1	0 V to 10 V	PTI	Not used
		0 V to 10 V	IPos	Not used
		-10 V to +10 V	S	Speed setpoint (reference p29060) *
		0 V to 10 V	T	Speed limit (reference p29060) *
21, 22	Analog input 2	0 V to 10 V	PTI	Torque limit (reference r0333)
		0 V to 10 V	IPos	Torque limit (reference r0333)
		0 V to 10 V	S	Torque limit (reference r0333)
		-10 V to +10 V	T	Torque setpoint (reference r0333)

\* If the AI input voltage is higher than 10 V, the speed is not limited to the value at 10 V (p29060), but scaled according to p29060. For example, if p29060 = 3000 rpm, the speed is 3300 rpm at 11 V and 3600 rpm at 12 V.

#### Command voltage

The command voltage of the analog inputs always follows the formula below:

$$V_{\text{input}} = (\text{AI}+) - (\text{AI}-)$$

#### 4.3.3.2 AOs

The SINAMICS V90 has two analog outputs. You can find detailed information about these two analog outputs from the table below:

Pin No.	Analog output	Output voltage	Function
46	Analog output 1	-10 V to +10 V	Analog output 1 for monitoring
48	Analog output 2	-10 V to +10 V	Analog output 2 for monitoring

**Parameterization**

Two parameters, p29350 (selects signal sources for AO1) and p29351 (selects signal sources for AO2), are used to select the source of analog output:

Parameter	Value	Source
p29350	0 (default)	Actual speed (reference p29060)
	1	Actual torque (reference $3 \times r0333$ )
	2	Speed setpoint (reference p29060)
	3	Torque setpoint (reference $3 \times r0333$ )
	4	DC bus voltage (reference 1000 V)
	5	Pulse input frequency (reference 1 k)
	6	Pulse input frequency (reference 10 k)
	7	Pulse input frequency (reference 100 k)
	8	Pulse input frequency (reference 1000 k)
	9	Remaining number of pulses (reference 1 k)
	10	Remaining number of pulses (reference 10 k)
	11	Remaining number of pulses (reference 100 k)
	12	Remaining number of pulses (reference 1000 k)
p29351	0	Actual speed (reference p29060)
	1 (default)	Actual torque (reference $3 \times r0333$ )
	2	Speed setpoint (reference p29060)
	3	Torque setpoint (reference $3 \times r0333$ )
	4	DC bus voltage (reference 1000 V)
	5	Pulse input frequency (reference 1 k)
	6	Pulse input frequency (reference 10 k)
	7	Pulse input frequency (reference 100 k)
	8	Pulse input frequency (reference 1000 k)
	9	Remaining number of pulses (reference 1 k)
	10	Remaining number of pulses (reference 10 k)
	11	Remaining number of pulses (reference 100 k)
	12	Remaining number of pulses (reference 1000 k)

**Wiring**

Do wiring of analog outputs as follows:

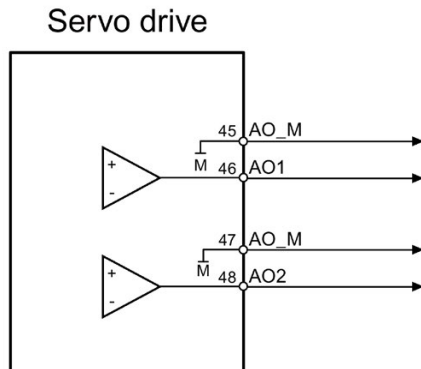

### 4.3.4 Standard application wiring (factory setting)

#### 4.3.4.1 Pulse train input position control (PTI)

Standard wiring for pulse train input position control mode:

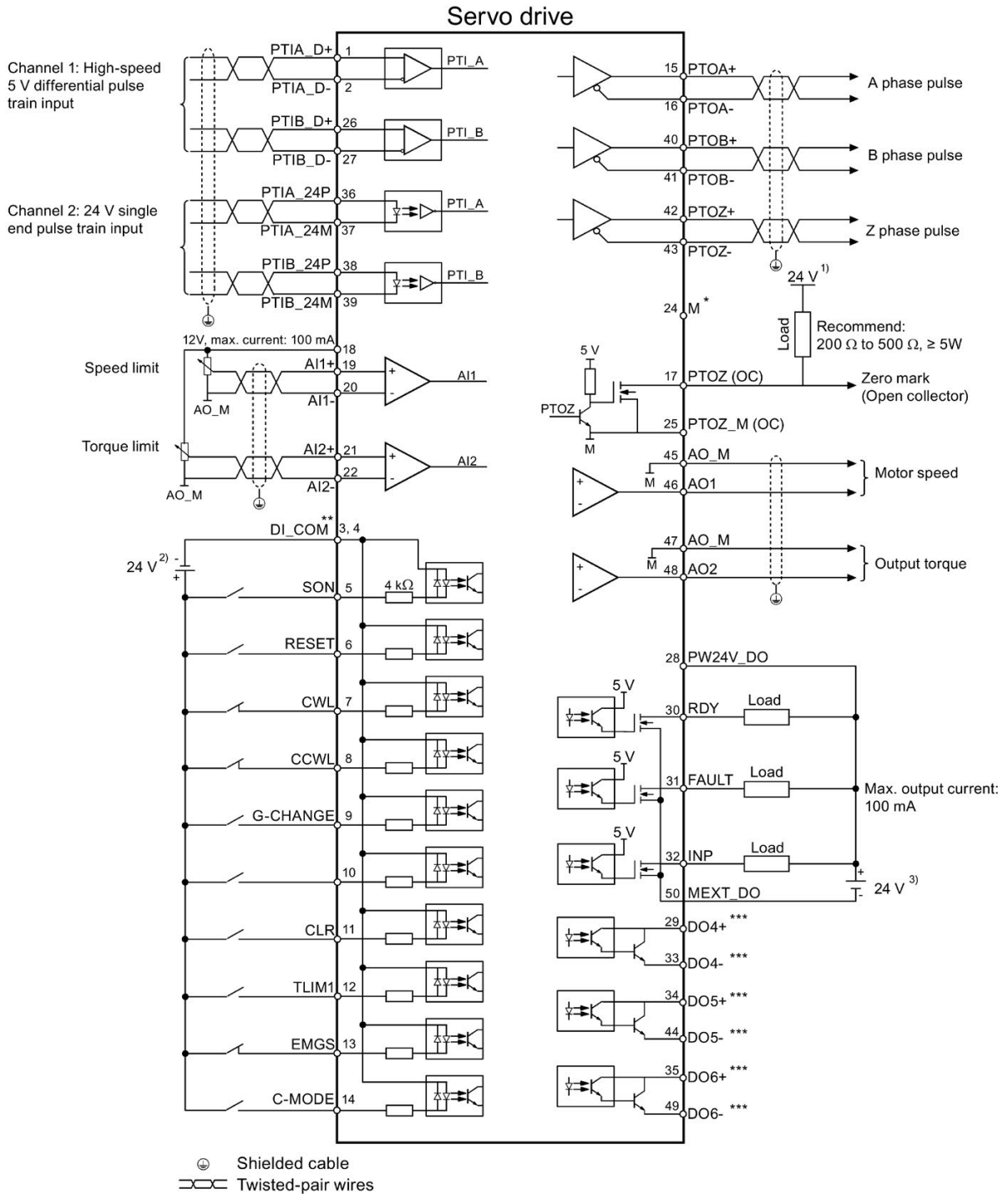

- \* PTO and PTI\_D reference ground, connected to the reference ground of the host controller.
- \*\* Digital inputs, supporting both the PNP and the NPN types.
- \*\*\* Digital outputs, supporting both the PNP and the NPN types.  
For detailed information about these two wiring types, see Section "DOs (Page 112)".

The 24 V power supplies in the connection diagram are as follows:

- 1) 24 V power supply for SINAMICS V90. All the PTO signals must be connected to the controller with the same 24 V power supply as SINAMICS V90.
- 2) Isolated digital input power supply. It can be the controller power supply.
- 3) Isolated digital output power supply. It can be the controller power supply.

---

**Note**

Only one of the pulse train input channels can be used.

---

### 4.3.4.2 Internal position control (IPos)

Standard wiring for internal position control mode:

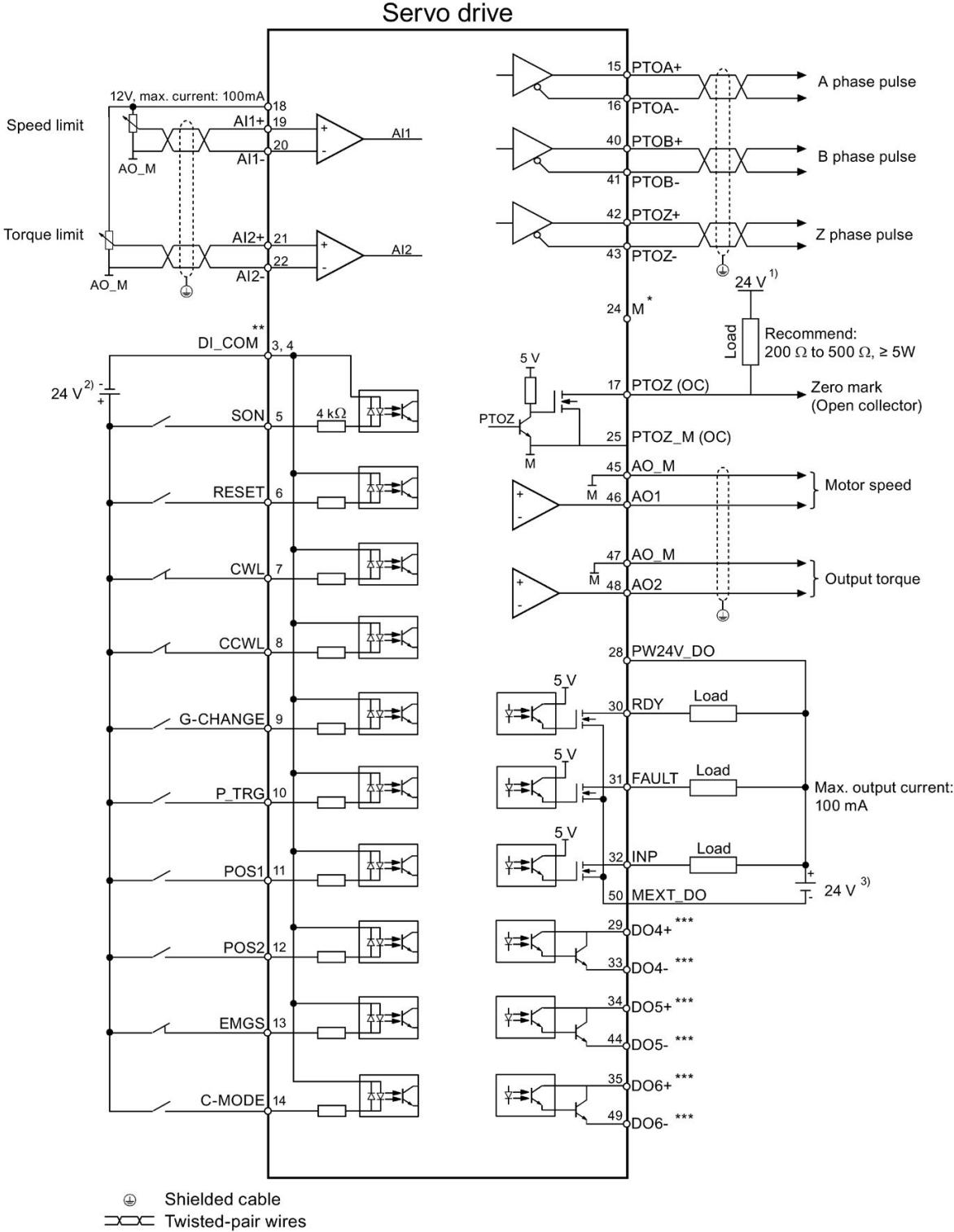

- \* PTO and PTI\_D reference ground, connected to the reference ground of the host controller.
- \*\* Digital inputs, supporting both PNP and NPN types.
- \*\*\* Digital outputs, supporting both the PNP and the NPN types.  
For detailed information about these two wiring types, see Section "DOs (Page 112)".

The 24 V power supplies in the connection diagram are as follows:

- 1) 24 V power supply for SINAMICS V90. All the PTO signals must be connected to the controller with the same 24 V power supply as SINAMICS V90.
- 2) Isolated digital input power supply. It can be the controller power supply.
- 3) Isolated digital output power supply. It can be the controller power supply.



4.3.4.3 Speed control (S)

Standard wiring for speed control mode:

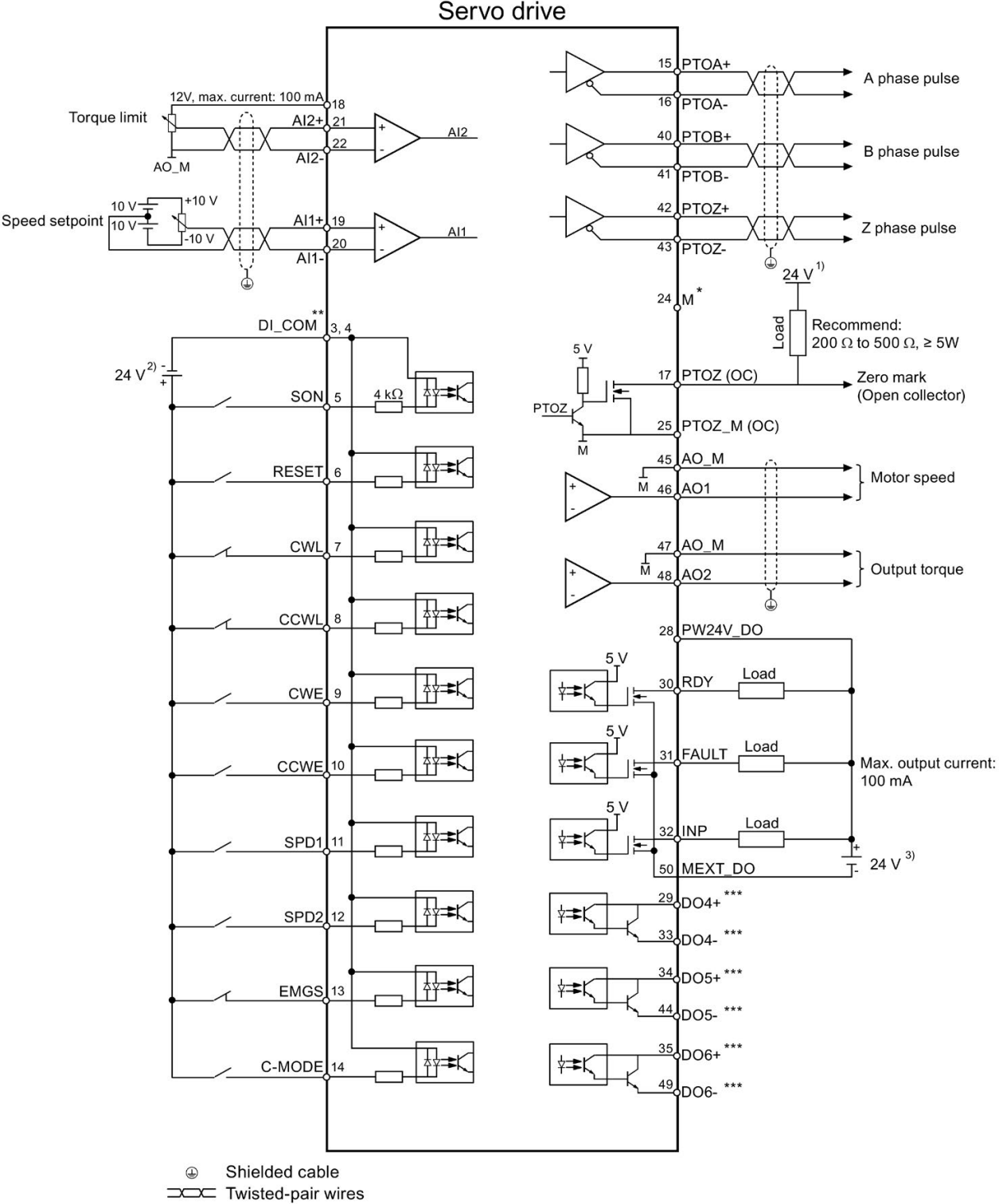

- \* PTO and PTI\_D reference ground, connected to the reference ground of the host controller.
- \*\* Digital inputs, supporting both PNP and NPN types.
- \*\*\* Digital outputs, supporting both the PNP and the NPN types.  
For detailed information about these two wiring types, see Section "DOs (Page 112)".

The 24 V power supplies in the connection diagram are as follows:

- 1) 24 V power supply for SINAMICS V90. All the PTO signals must be connected to the controller with the same 24 V power supply as SINAMICS V90.
- 2) Isolated digital input power supply. It can be the controller power supply.
- 3) Isolated digital output power supply. It can be the controller power supply.

---

**Note**

The analog outputs to analog inputs on the servo unit and the 24V input for the servo unit **must** use a common ground (M).

---

### 4.3.4.4 Torque control (T)

Standard wiring for torque control mode:

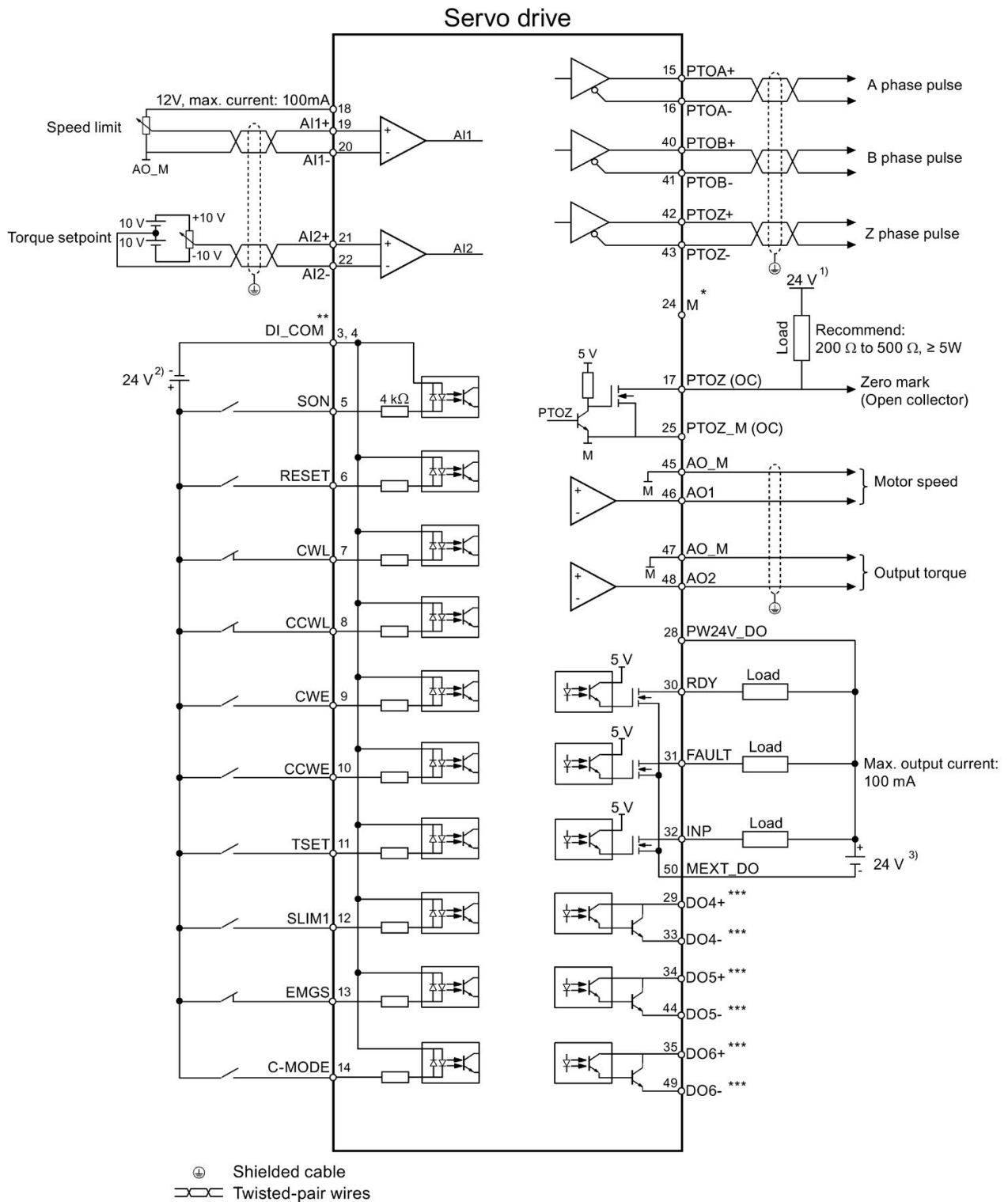

- \* PTO and PTI\_D reference ground, connected to the reference ground of the host controller.
- \*\* Digital inputs, supporting both PNP and NPN types.
- \*\*\* Digital outputs, supporting both the PNP and the NPN types.  
For detailed information about these two wiring types, see Section "DOs (Page 112)".

The 24 V power supplies in the connection diagram are as follows:

- 1) 24 V power supply for SINAMICS V90. All the PTO signals must be connected to the controller with the same 24 V power supply as SINAMICS V90.
- 2) Isolated digital input power supply. It can be the controller power supply.
- 3) Isolated digital output power supply. It can be the controller power supply.

---

**Note**

The analog outputs to analog inputs on the servo unit and the 24V input for the servo unit **must** use a common ground (M).

---

### 4.3.5 Connection examples with PLCs

This section gives examples of connections between the drive and the PLC. All of the connection examples shown in this section are made based on factory default settings for digital inputs/outputs. You can assign different digital inputs/outputs based on your actual requirement.

#### 4.3.5.1 SIMATIC S7-200 SMART

##### Pulse train input position control (PTI)

When connecting to different axes, the outputs are different. The diagram below takes the connection with axis 0 for example.

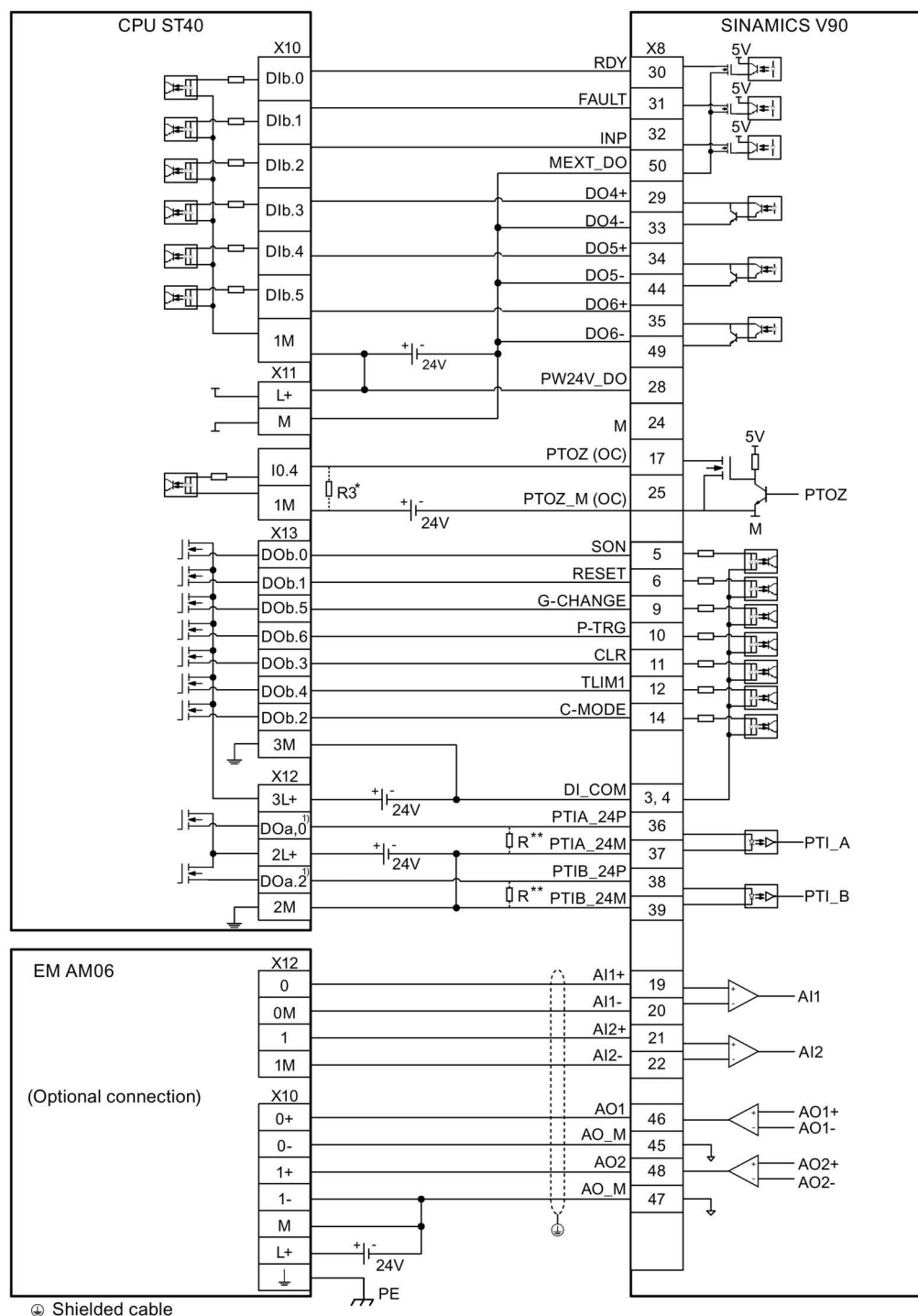

- 1) When connect to axis 1, the outputs are DO a.1 and DO a.7;  
When connect to axis 2, the outputs are DO a.3 and DO b.0.
- \* The resistor R3 (200 Ohm to 500 Ohm) is required only if the speed for searching the zero position exceeds 300 rpm.
- \*\* The resistor R (200 Ohm to 500 Ohm, recommended power  $\geq 5$  W ) is required only if the PTI input frequency exceeds 100 KHz.

Internal position control (IPos)

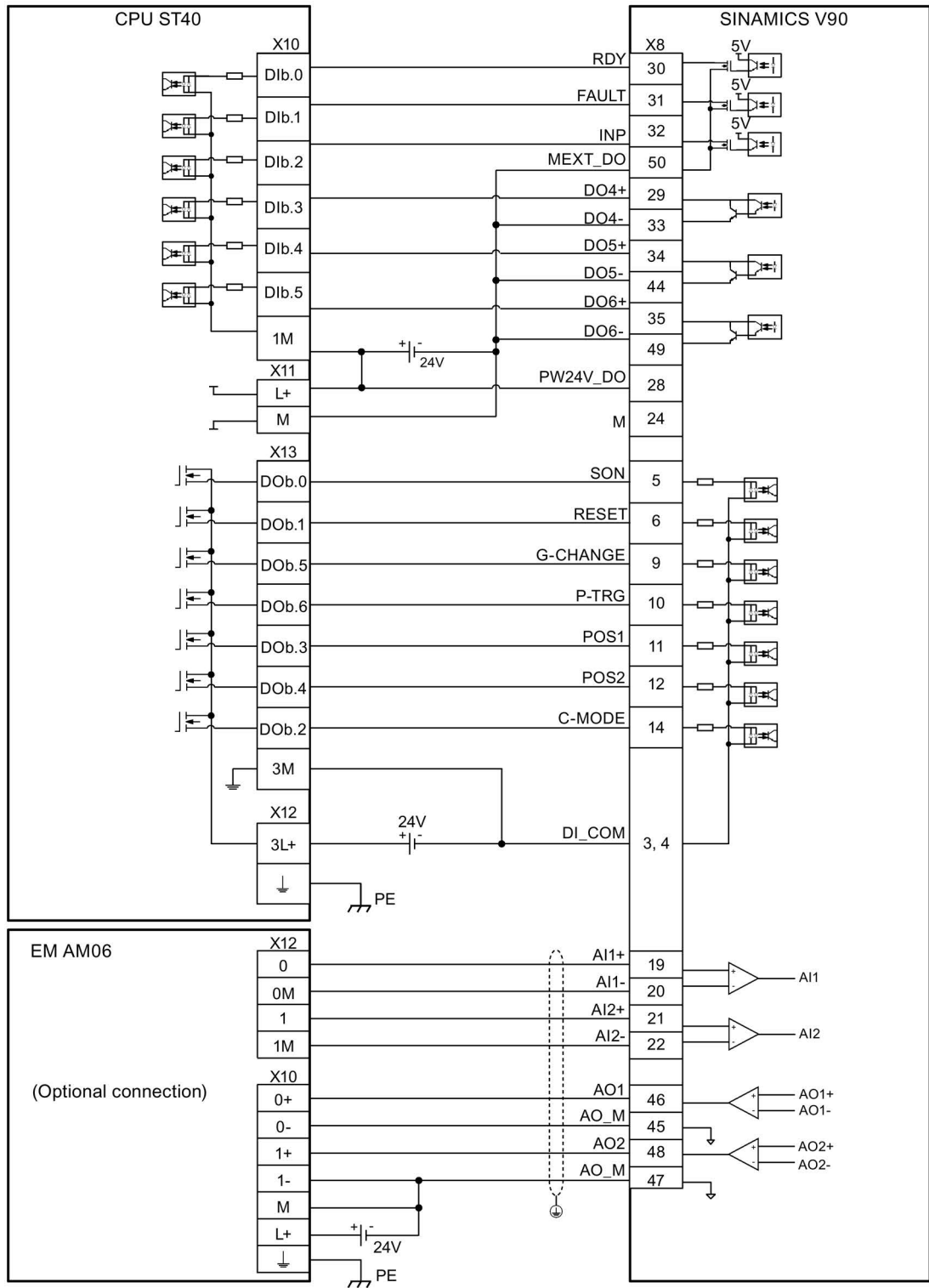

⊕ Shielded cable

Speed control (S)

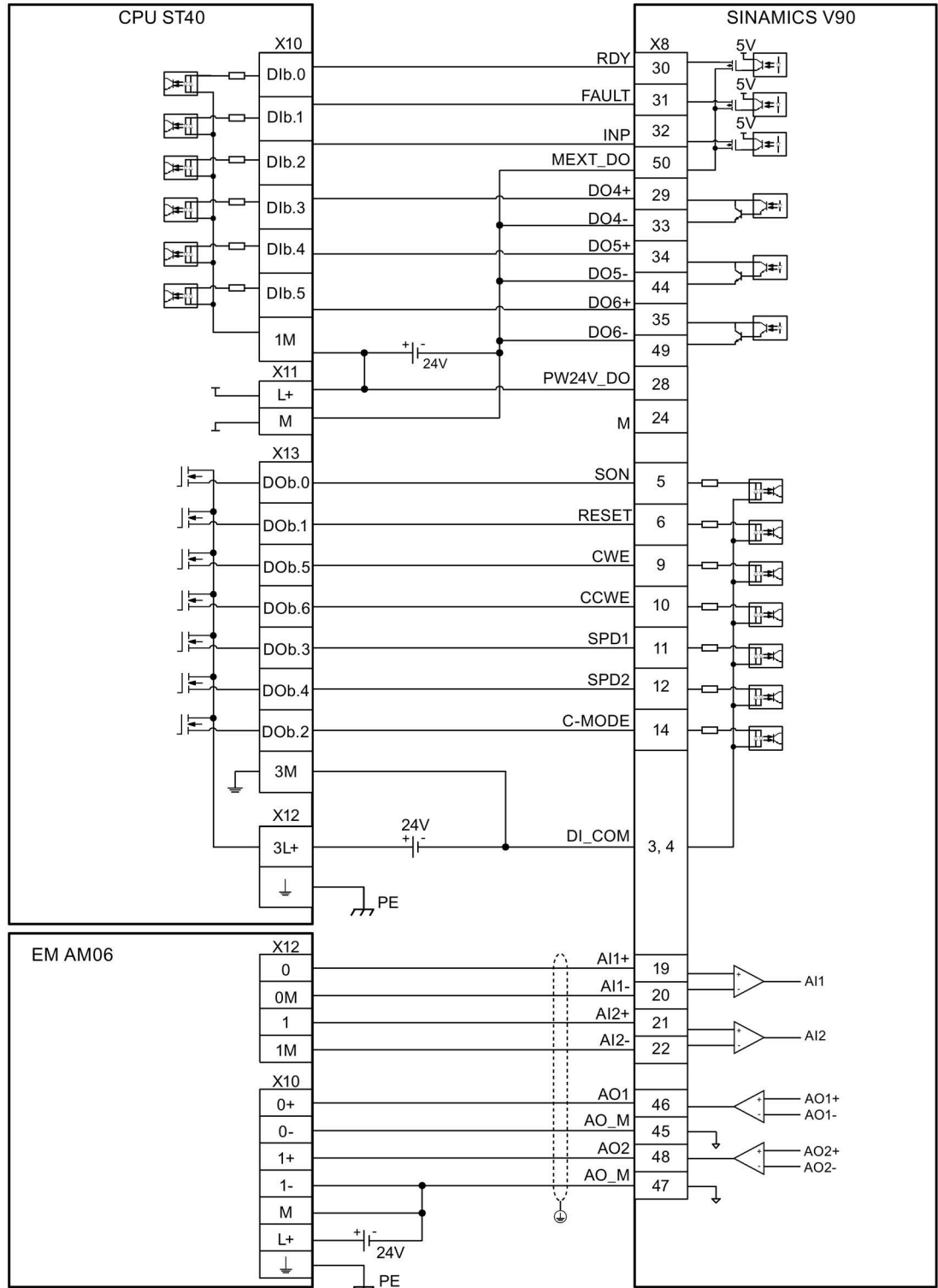

⊕ Shielded cable

Torque control (T)

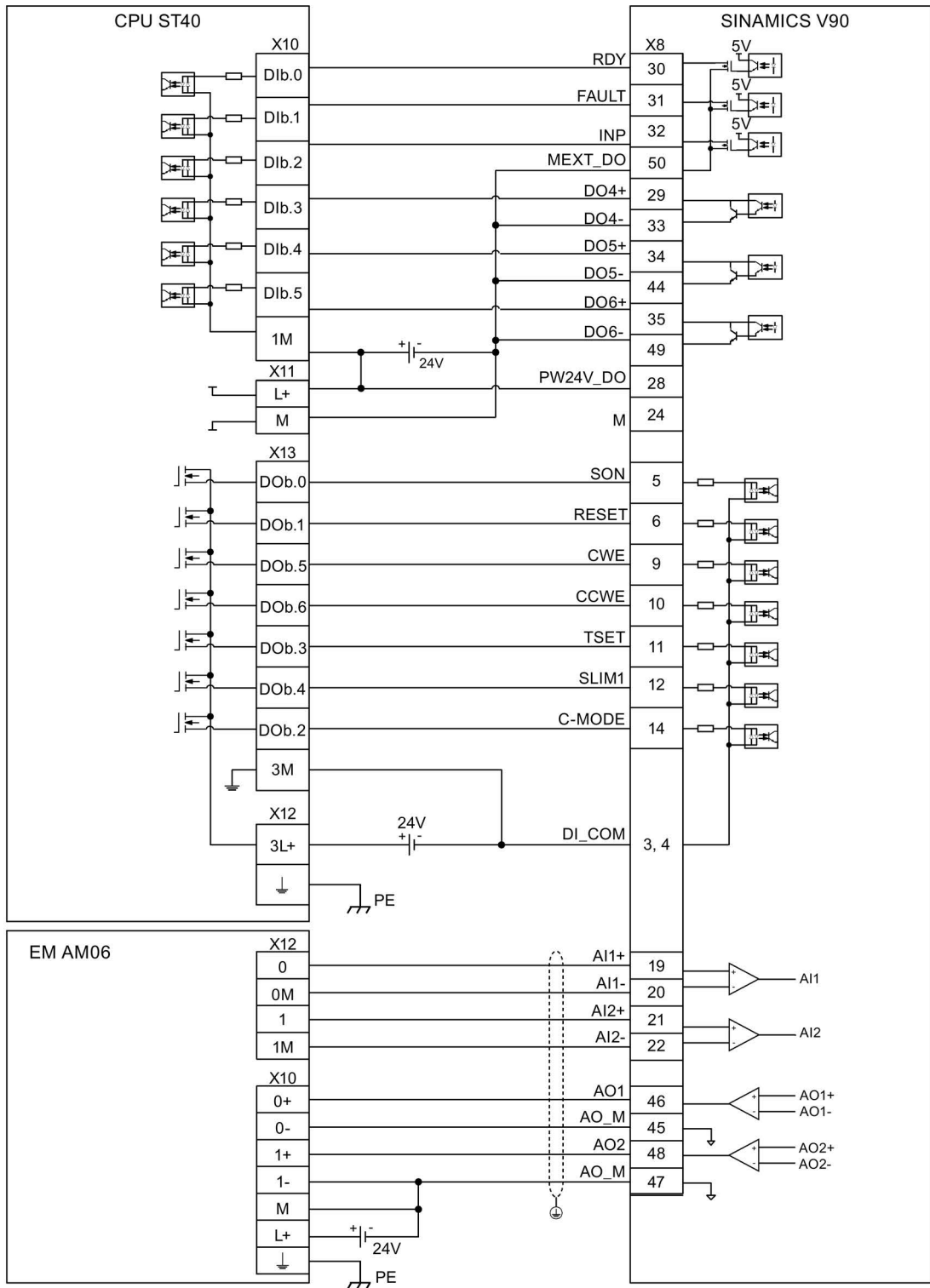



### 4.3.5.2 SIMATIC S7-200

#### Pulse train input position control (PTI)

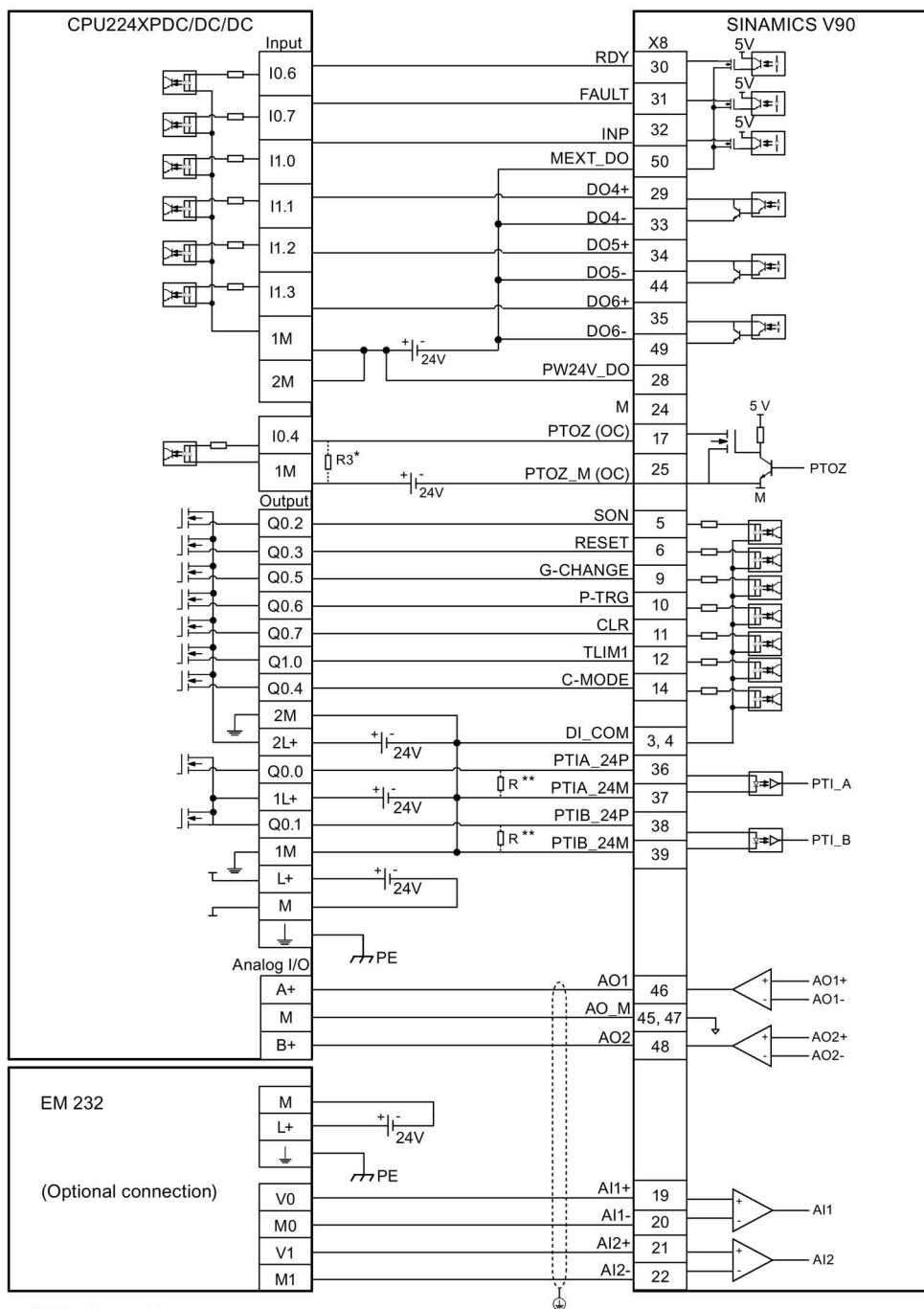

Ⓢ Shielded cable

\* The resistor R3 (200 Ohm to 500 Ohm) is required only if the speed for searching the zero position exceeds 300 rpm.

\*\* The resistor R (200 Ohm to 500 Ohm, recommended power  $\geq 5$  W) is required only if the PTI input frequency exceeds 100 KHz.

Internal position control (IPos)

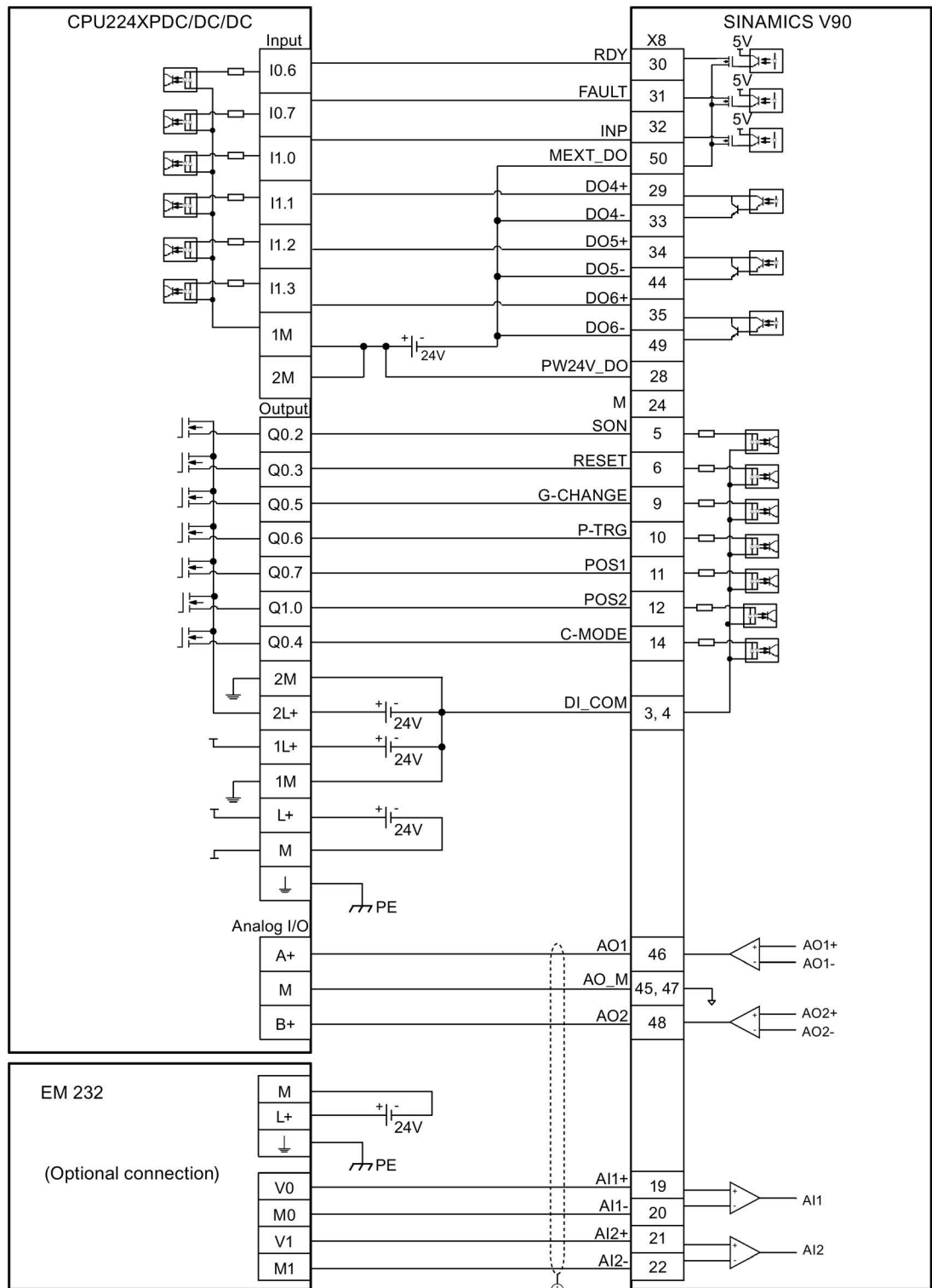

⊕ Shielded cable

Speed control (S)

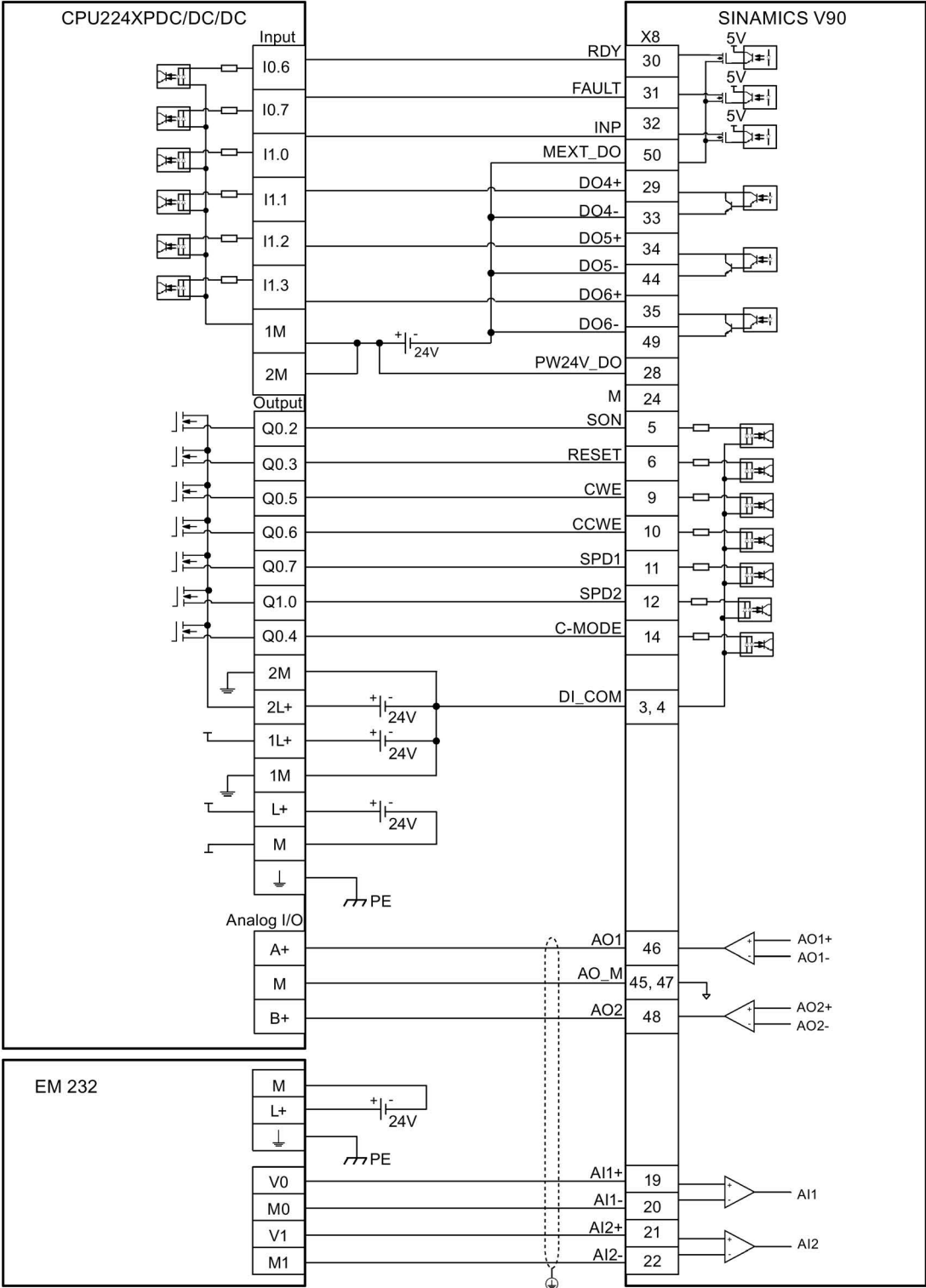

⊕ Shielded cable

Torque control (T)

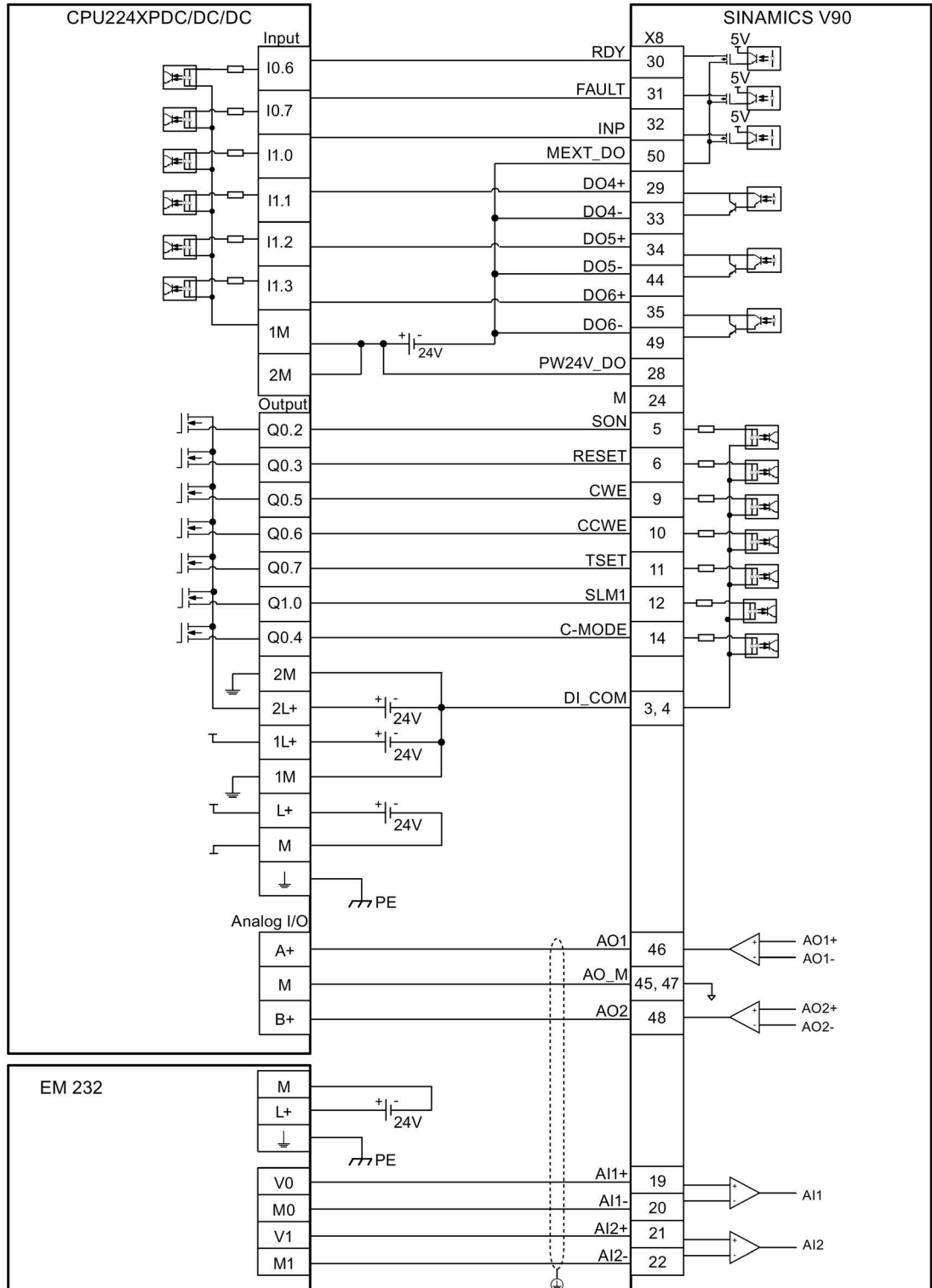

⊕ Shielded cable

4.3.5.3 SIMATIC S7-1200

Pulse train input position control (PTI)

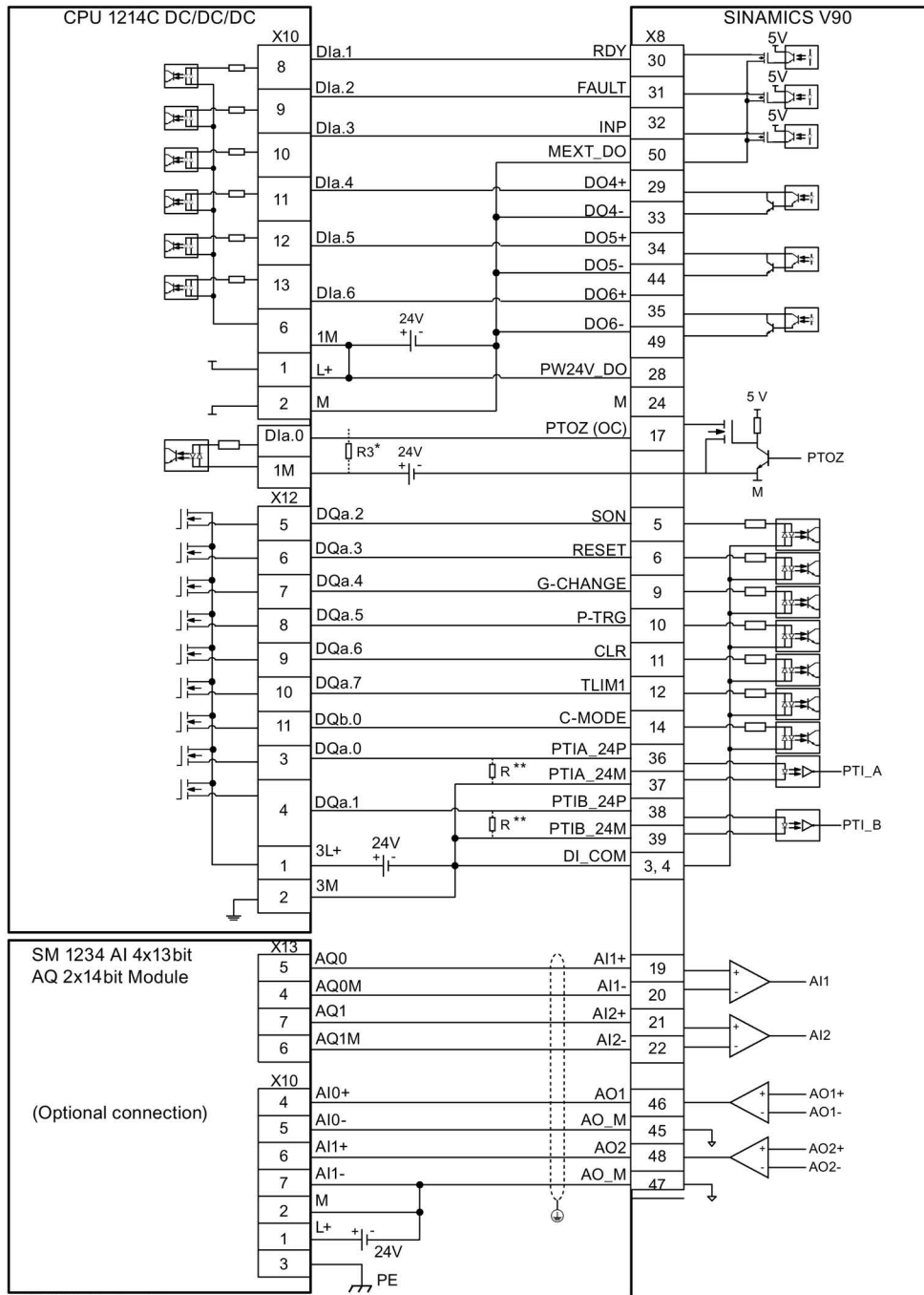

⊕ Shielded cable

\* The resistor R3 (200 Ohm to 500 Ohm) is required only if the speed for searching the zero position exceeds 300 rpm.

\*\* The resistor R (200 Ohm to 500 Ohm, recommended power  $\geq 5 W$ ) is required only if the PTI input frequency exceeds 100 KHz.

Internal position control (IPos)

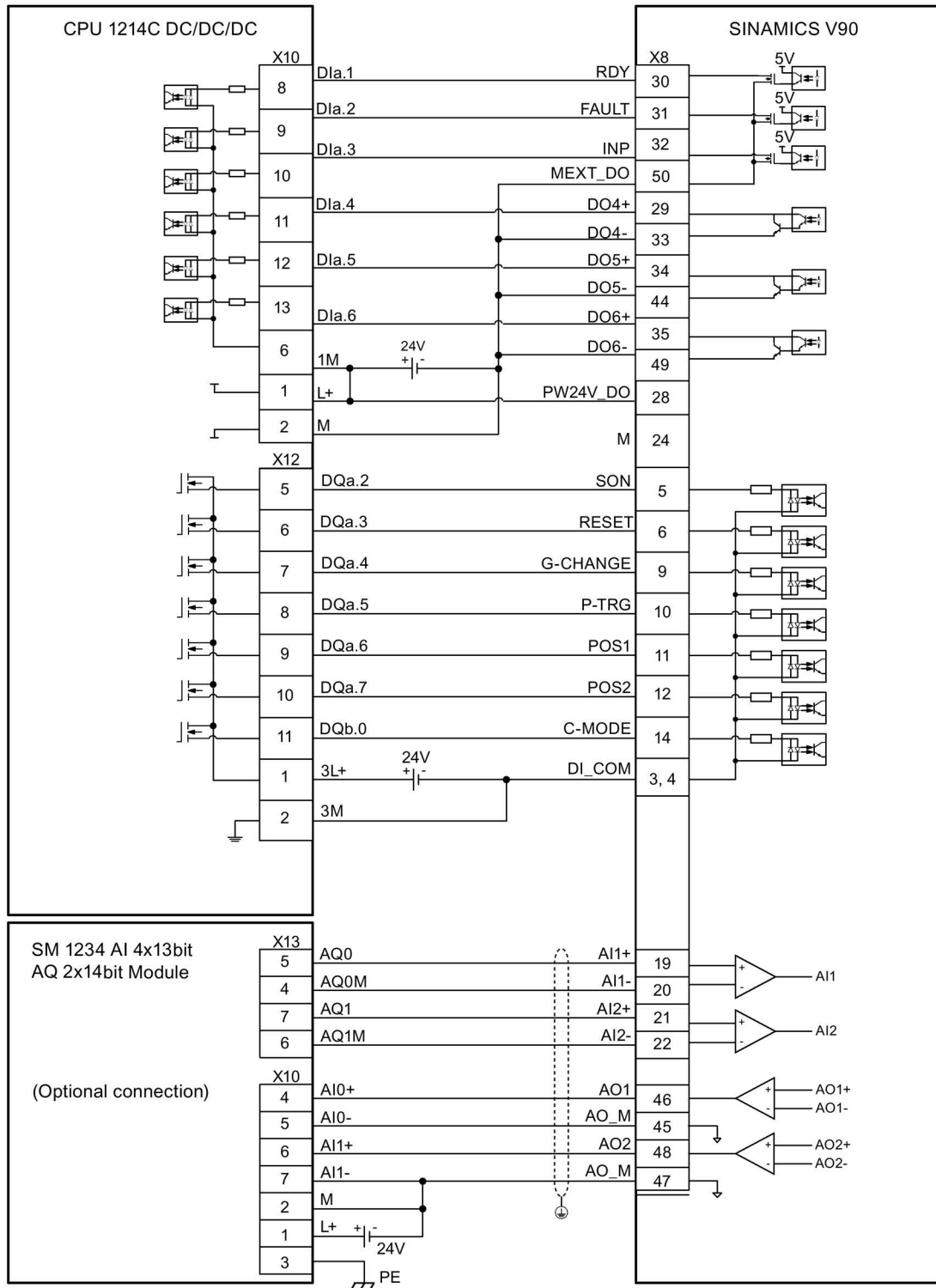

Ⓢ Shielded cable

Speed control (S)

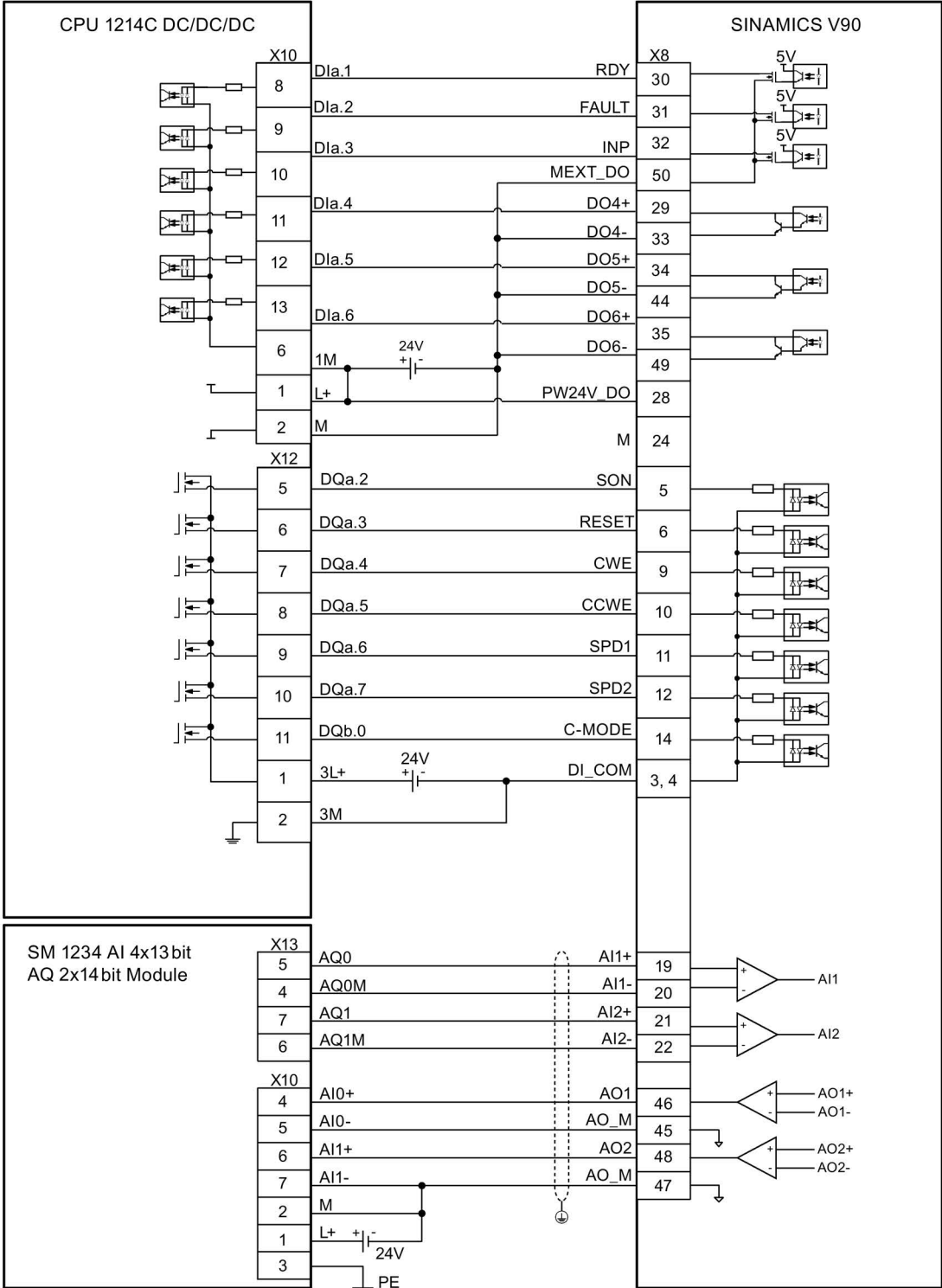

⊕ Shielded cable

Torque control (T)

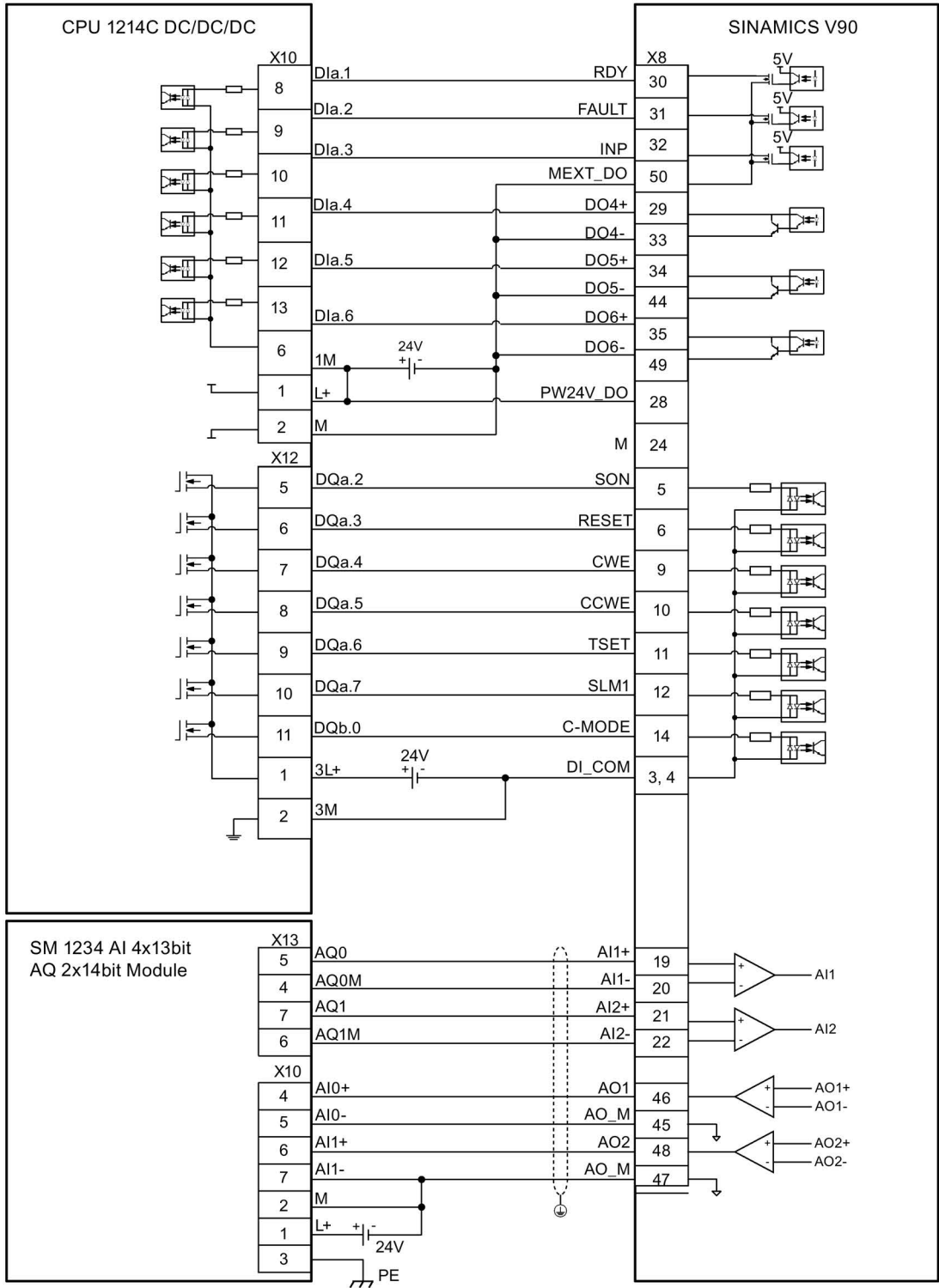



## 4.4 24 V power supply/STO

### Pin assignment

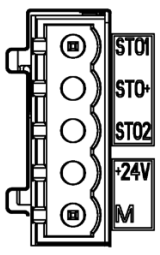
Interface	Signal name	Description	Remarks
	STO 1	Safe torque off channel 1	-
	STO +	Power supply for safe torque off	-
	STO 2	Safe torque off channel 2	-
	+24 V	Power supply, 24 VDC	Voltage tolerance: <ul style="list-style-type: none"> <li>• Without brake: -15% to +20%</li> <li>• With brake: -10% to +10%</li> </ul> Maximum current consumption: <ul style="list-style-type: none"> <li>• Without brake: 1.6 A</li> <li>• With brake: 1.6 A + motor holding brake rated current (See Section "Technical data - servo motors (Page 61)")</li> </ul>
	M	Power supply, 0 VDC	
Maximum conductor cross-section: 1.5 mm <sup>2</sup>			

### Wiring

#### WARNING

##### Material damages and personal injuries by the drop of a hanging axis

When the servo system is used as a hanging axis, the axis will drop if the positive and negative poles of the 24 V power supply are connected inversely. Unexpected drop of the hanging axis can cause material damages and personal injuries.

- Make sure that the 24 V power supply is correctly connected.

#### WARNING

##### Material damages and personal injuries by the drop of a hanging axis

Unexpected drop of the hanging axis can cause material damages and personal injuries.

- It is not allowed to use the STO with a hanging axis because the axis may drop.

#### Note

##### Using the STO function

The STO1, STO+ and STO2 are short connected at the factory setting.

When the STO function is to be used, you must remove the short-circuit stick before connecting the STO interfaces. The safety function of the servo drive is SIL 2 (EN61800-5-2). If you do not need to use it any more, you must reinsert the short-circuit stick; otherwise, the motor will not run.

For detailed information about the STO function, refer to "Safety Integrated basic functions (Page 280)".

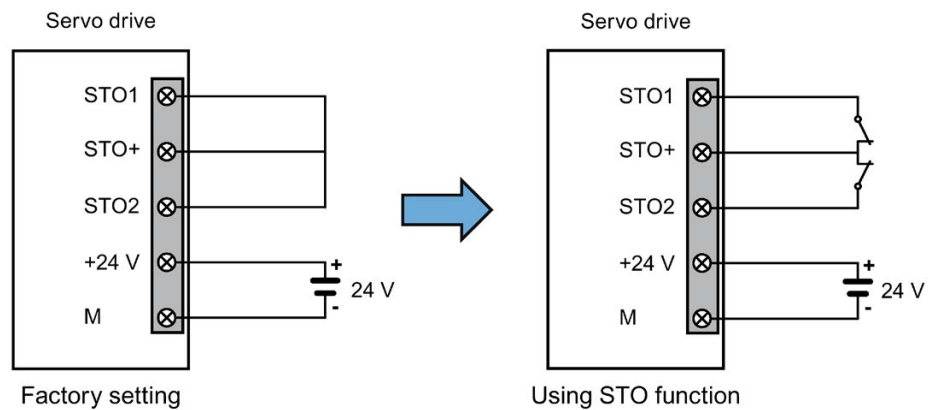

### Assembling the 24 V power supply and STO cable terminals

The procedure of assembling a 24 V power cable terminal or an STO cable terminal is the same as that for a power cable terminal on the drive side of the V90 200 V servo drives.

For more information, see Section "Assembly of cable terminals on the drive side (Page 373)".

### Plugging the 24 V power supply and STO cables

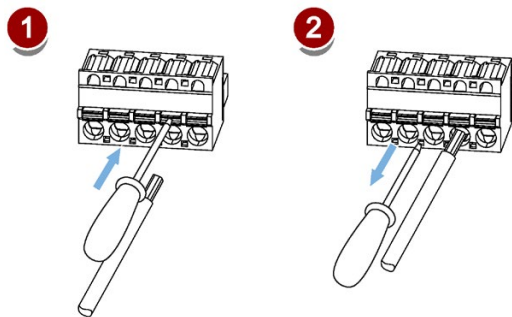

## 4.5 Encoder interface - X9

The SINAMICS V90 200V variant servo drive supports two kinds of encoders:

- Incremental encoder TTL 2500 ppr
- Absolute encoder single-turn 21-bit
- Absolute encoder 20-bit + 12-bit multi-turn

The SINAMICS V90 400V variant servo drive supports two kinds of encoders:

- Incremental encoder TTL 2500 ppr
- Absolute encoder 20-bit + 12-bit multi-turn

**NOTICE****Drive damage caused by short-circuiting between the shielding wire and the unused pin on the encoder connector**

The shielding wire may inadvertently be short-circuited to the unused pin on the to-be-assembled encoder connector. This can cause damage to the drive.

- Exercise caution when connecting the shielding cable to the encoder connector.
- For more information, see Section "Assembly of cable terminals on the drive side (Page 373)".

**Note****Failure to meet the EMC requirements because the cable is not shielded**

If a cable is not shielded, it cannot meet the EMC requirements.

- The encoder cable **must** be shielded to meet the EMC requirements.

**Encoder interface - drive side**

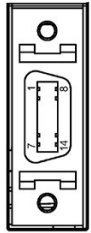
Illustration	Pin	Signal name	Description
	1	Biss_DataP	Absolute encoder data signal, positive
	2	Biss_DataN	Absolute encoder data signal, negative
	3	Biss_ClockN	Absolute encoder clock signal, negative
	4	Biss_ClockP	Absolute encoder clock signal, positive
	5	P5V	Encoder power supply, 5 V
	6	P5V	Encoder power supply, 5 V
	7	M	Encoder power supply, grounding
	8	M	Encoder power supply, grounding
	9	Rp	Encoder R phase positive signal
	10	Rn	Encoder R phase negative signal
	11	Bn	Encoder B phase negative signal
	12	Bp	Encoder B phase positive signal
	13	An	Encoder A phase negative signal
	14	Ap	Encoder A phase positive signal
Screw type: UNC 4-40 (plug-in terminal block)			
Tightening torque: 0.4 Nm			

Encoder connector - motor side

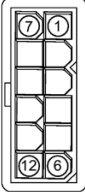
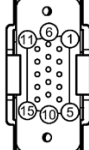
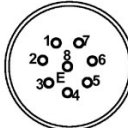

Illustration	Pin	Incremental encoder TTL 2500 ppr		Illustration	Absolute encoder single-turn 21-bit Absolute encoder 20-bit + 12-bit multi-turn		
		Signal	Description		Signal	Description	
<b>Low inertia motor, shaft-height: 20 mm, 30 mm and 40 mm</b>							
	1	P_Supply	Power supply 5 V		P_Supply	Power supply 5 V	
	2	M	Power supply 0 V		M	Power supply 0 V	
	3	A+	Phase A+		Clock_P	Clock	
	4	B+	Phase B+		Data_P	Data	
	5	R+	Phase R+		n. c.	Not connected	
	6	n. c.	Not connected		P_Supply	Power supply 5 V	
	7	P_Supply	Power supply 5 V		M	Power supply 0 V	
	8	M	Power supply 0 V		Clock_N	Inverted clock	
	9	A-	Phase A-		Data_N	Inverted data	
	10	B-	Phase B-		Shielding	Grounding	
	11	R-	Phase R-		<b>Note</b> The pin11 to pin15 of the absolute encoder connector are not connected.		
	12	Shielding	Grounding				

Illustration	Pin	Incremental encoder TTL 2500 ppr		Absolute encoder single-turn 21-bit Absolute encoder 20-bit + 12-bit multi-turn	
		Signal	Description	Signal	Description
<b>Low inertia motor, shaft-height: 50 mm</b>					
<b>High inertia motor, shaft-height: 45 mm, 65 mm, and 90 mm</b>					
Straight connectors:   Angular connectors: 	1	P_Supply	Power supply 5 V	P_Supply	Power supply 5 V
	2	M	Power supply 0 V	M	Power supply 0 V
	3	A+	Phase A+	n. c.	Not connected
	4	A-	Phase A-	Clock_N	Inverted clock
	5	B+	Phase B+	Data_P	Data
	6	B-	Phase B-	Clock_P	Clock
	7	R+	Phase R+	n. c.	Not connected
	8	R-	Phase R-	Data_N	Inverted data

Wiring

Low inertia motor, shaft-height: 20 mm, 30 mm and 40 mm

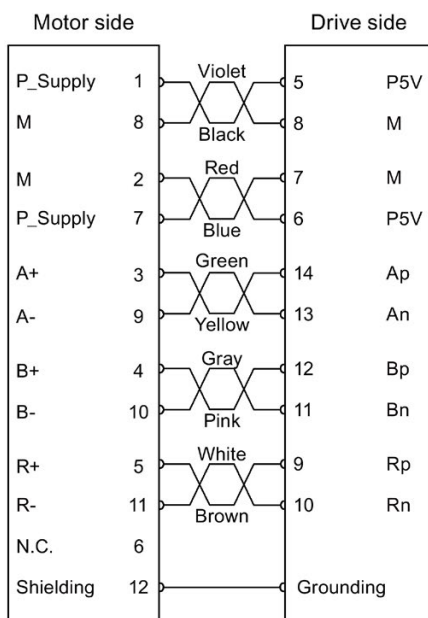

Incremental encoder TTL 2500 ppr

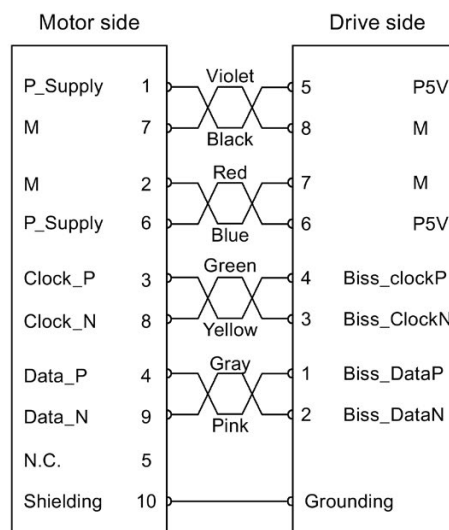

Absolute encoder single-turn 21-bit  
Absolute encoder 20 bit + 12 bit multi-turn

Twisted-pair wires

Low inertia motor, shaft-height: 50 mm

High inertia motor, shaft-height: 45 mm, 65 mm, and 90 mm

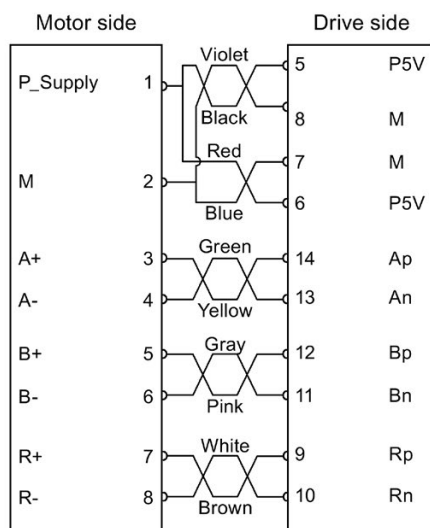

Incremental encoder TTL 2500 ppr

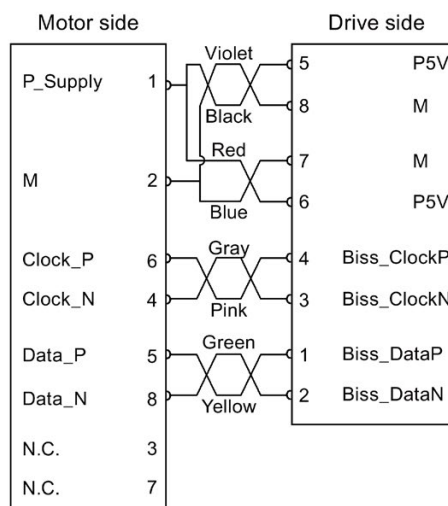

Absolute encoder single-turn 21-bit  
Absolute encoder 20-bit + 12-bit multi-turn

Twisted-pair wires

### Grounding

To ensure better EMC effects, you are recommended to strip the encoder cable and connect the cable shield to earth, as shown in the following figure:

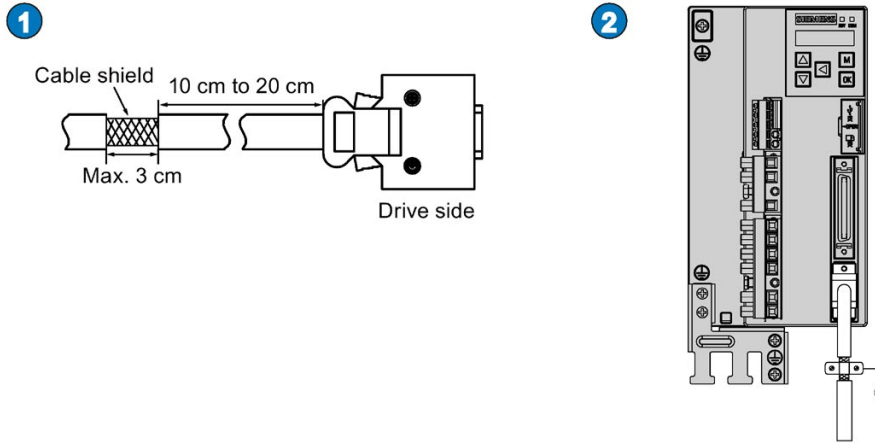

## 4.6 External braking resistor - DCP, R1

The SINAMICS V90 has been designed with an internal braking resistor to absorb regenerative energy from the motor. When the internal braking resistor cannot meet the braking requirements (e.g. the alarm A52901 is generated), you can connect an external braking resistor. For more information about how to select a braking resistor, see Section "Braking resistor (Page 45)".

### Note

The 200 V variant servo drive with rated power of 0.1 kW (FSA) does not have a built-in resistor.

### Connecting an external braking resistor

#### NOTICE

#### Damage to the drive due to not moving the short-circuit stick between terminals DCP and R2

There is a damage to the drive if you do not move the short-circuit stick between terminals DCP and R2 when using an external resistor.

- Before connecting an external resistor to DCP and R1, remove the connection between terminals DCP and R2.

For more information about how to connect the external braking resistor, see Section "System connection (Page 92)".

## 4.7 Motor holding brake

The motor holding brake is used to prevent the moving load from unwanted motions (for example, falling under the influence of gravity) when the servo system is deactivated (for example, the servo power is shut off). The servo motor can move because of its own weight or an external force even the motor power has been cut off.

The holding brake is built in the servo motors with brakes.

For 400 V variant servo drive, a motor holding brake interface (X7) is integrated in the front panel. You can connect it to a servo motor with brake to use the function of motor holding brake directly.

For 200 V variant servo drive, no specific motor holding brake interface is integrated. To use the function, you need to connect the drive to a third-party device via the control/status interface (X8).



### Note

- Use this brake for the "hold" purpose only, that is, to hold the stalling state only. Never use this for the "brake" purpose to stop the load in motion. Use the holding brake only to hold a stopped motor.
- The holding brake is activated at the same time when the motor power is cut off.

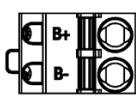
### Motor holding brake interface - drive side (for 400 V variant servo drive only)

Illustration	Signal	Description
	B+	24 V, motor brake voltage positive
	B-	0 V, motor brake voltage negative
Maximum conductor cross-section: 1.5 mm <sup>2</sup> Input voltage tolerance: 24 V ± 10%		

### Motor holding brake connector - motor side

Illustration	Pin No.	Signal	Description
<b>Low inertia motor, shaft-height: 20 mm, 30 mm and 40 mm</b>			
	1	Brake+	Phase Brake+
	2	Brake-	Phase Brake-
<b>Low inertia motor, shaft-height: 50 mm</b> <b>High inertia motor, shaft-height: 45 mm, 65 mm, and 90 mm</b>			
Straight connectors: 	1	Brake+	Phase Brake+
	2	Brake-	Phase Brake-
Angular connectors: 			

**Signal status**

The following table describes the states of various interfaces and components when the brake works.

- 200 V variant

Status	MBR (DO)	Brake control (Brake)	Relay	Motor brake function	Motor shaft
Brake engagement	High level (1)	Brake off	Without current	Opened	Cannot run
Brake release	Low level (0)	Brake on	With current	Closed	Can run

- 400 V variant

Status	MBR (DO)	Brake control (B+, B-)	Motor brake function	Motor shaft
Brake engagement	High level (1)	0 V	Opened	Cannot run
Brake release	Low level (0)	24 V	Closed	Can run

**DO signal**

Signal type	Signal name	Pin assignment	Setting	Description
DO	MBR	X8-35/49 (factory setting)	ON = high level (1)	Motor holding brake is closed.
			OFF = low level (0)	Motor holding brake is released.

You can also change the assignment of the digital output signal MBR and assign it to any DO pin with one of the following parameters:

Parameter	Range	Factory setting	Unit	Description
p29330	1 to 14	1 (RDY)	-	Assignment of digital output 1
p29331	1 to 14	2 (FAULT)	-	Assignment of digital output 2
p29332	1 to 14	3 (INP)	-	Assignment of digital output 3
p29333	1 to 14	5 (SPDR)	-	Assignment of digital output 4
p29334	1 to 14	6 (TLR)	-	Assignment of digital output 5
p29335	1 to 14	8 (MBR)	-	Assignment of digital output 6

**Note**

Refer to Section "Digital inputs/outputs (DIs/DOs) (Page 106)" for detailed information about the digital outputs.



## Wiring for the 200 V variant servo drive

The following shows the example when the brake is controlled through the motor holding brake signal (Brake) of the 200 V variant servo drive.

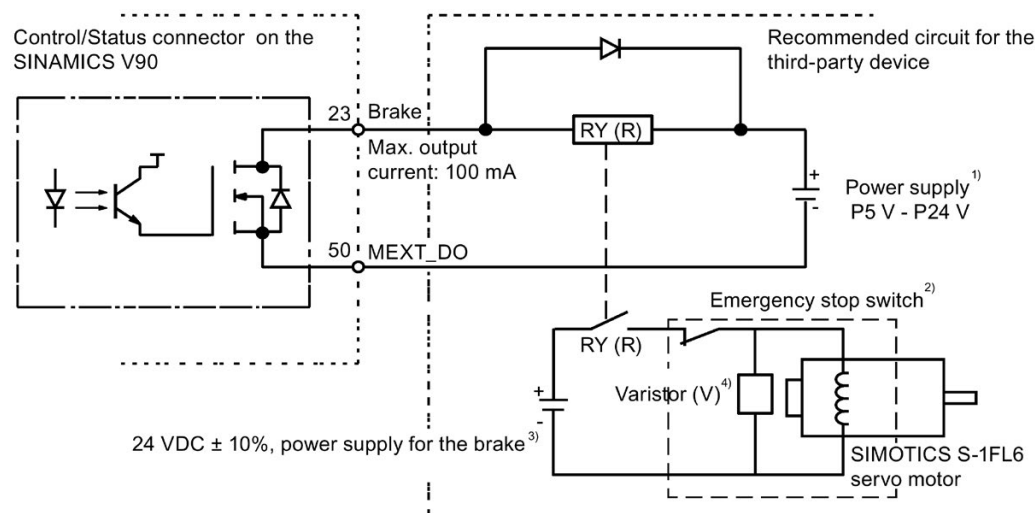

### Note

- 1) It is the isolated digital output power supply. Select a proper power supply based on the relay type (see below for the recommended relay type). When you use the 24 VDC power supply, it can be also the controller power supply.
- 2) The motor brake can be controlled not only by the brake control signal from the SINAMICS V90 servo drive but also by external emergency stop.
- 3) Make sure that you use different power supplies for the brake (24 VDC) and for the brake control signal (P24 V) separately to avoid electro-magnetic interference to electronic components.
- 4) Install a varistor as shown above to suppress the surge voltage or surge current generated by an ON/OFF action of the relay (RY).

### Varistor (V) used for the power supply of the brake

### Note

All the following data on a varistor is provided based on the low inertia motors with a rated power of 2 kW; however the data is also applicable to the low inertia motors of other power ranges.

Consider the following current-time and voltage-time characteristics when using a varistor to suppress the surge voltage or surge current:

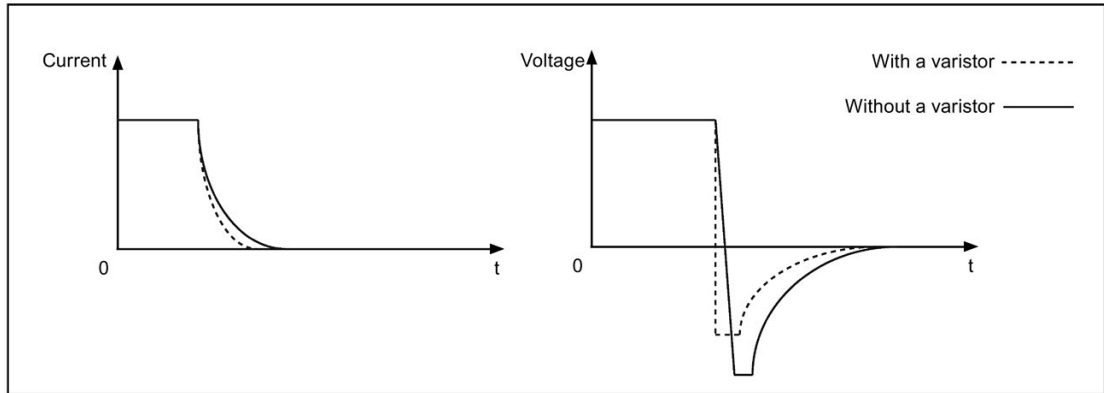

You may select an appropriate varistor with reference to the table below:

Power supply voltage of the brake		24 VDC±10%
Order information	Manufacturer	EPCOS
	Model	S20K20
Specification re-requirements	Operating temperature	-20 °C to 60 °C
	Delay switching frequency	< 10 times/min
	Maximum operating DC voltage	26 V
	Average power dissipation	0.2 W
	Voltage at 1 mA	33 V±10%
	Clamping voltage at 20 A (8/20 μs)	65 V
	Energy absorption (2 ms) at a time	18 J

**Relay (R) used for the power supply of the brake**

Siemens recommends you to select a Siemens relay (article number: 3RQ3018-2AB00).

You can find more information about Siemens relays from Chapter 05 of Catalog IC 10 - SIRIUS 2016 at the following Web site:

Siemens relays

[http://w3app.siemens.com/mcms/infocenter/content/en/Pages/order\\_form.aspx?nodeKey=key\\_517764&infotype=catalogs](http://w3app.siemens.com/mcms/infocenter/content/en/Pages/order_form.aspx?nodeKey=key_517764&infotype=catalogs)

You can also select other high quality relays from manufacturers such as Omron (article number: G2R-1A-E-DC24V) .

**Wiring for the 400 V variant servo drive**

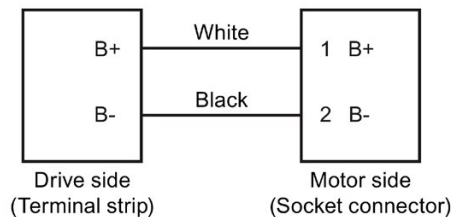

## Relevant parameters

No.	Unit	Range	Default	Description
p1215	-	0 to 3	0	Configuration of the holding brake. <ul style="list-style-type: none"> <li>0: No holding brake available</li> <li>1: Motor holding brake according to sequence control (SON)</li> <li>2: Motor holding brake always open</li> <li>3: SIEMENS internal use</li> </ul>
p1216	ms	0 to 10000	Motor dependent	Motor holding brake opening time.
p1217	ms	0 to 10000	Motor dependent	Motor holding brake closing time.

You can configure the holding brake with the parameter p1215 according to the actual application. When you set p1215=1, the motor holding brake is open once the digital input signal SON has a rising edge and becomes closed once a falling edge comes to SON.

If the servo motor is used to control a vertical axis, the machine movable part can have a slight shift when the holding brake becomes open or closed simultaneously with the action of SON. To eliminate such slight shift, you can configure a delay time for the close or open time of the motor holding brake by setting the parameters p1216 and p1217.

### Note

The default values of p1216 and p1217 depend on the rated power of the motor which connects to the servo drive.

### Note

For SINAMICS V90 200 V variant servo drives, the actual motor holding brake time consists of the time delay of the motor brake and the time delay of the current amplifying component (a relay in the example above); therefore, you can set the values of p1216 and p1217 as follows:

p1216 = motor brake opening time + relay opening time

p1217 = motor brake closing time + relay closing time

### NOTICE

#### Motor brake service life shortened due to the improper use

The motor brake is used for holding purpose only. Frequent emergency stops with the motor brake will shorten its service life.

- Unless absolutely necessary, do not apply the motor brake as an emergency stop or deceleration mechanism.

### Braking sequence

The operating principle of the holding brake is configured during motor selection for motors with incremental encoders and configured automatically for motors with absolute encoders.

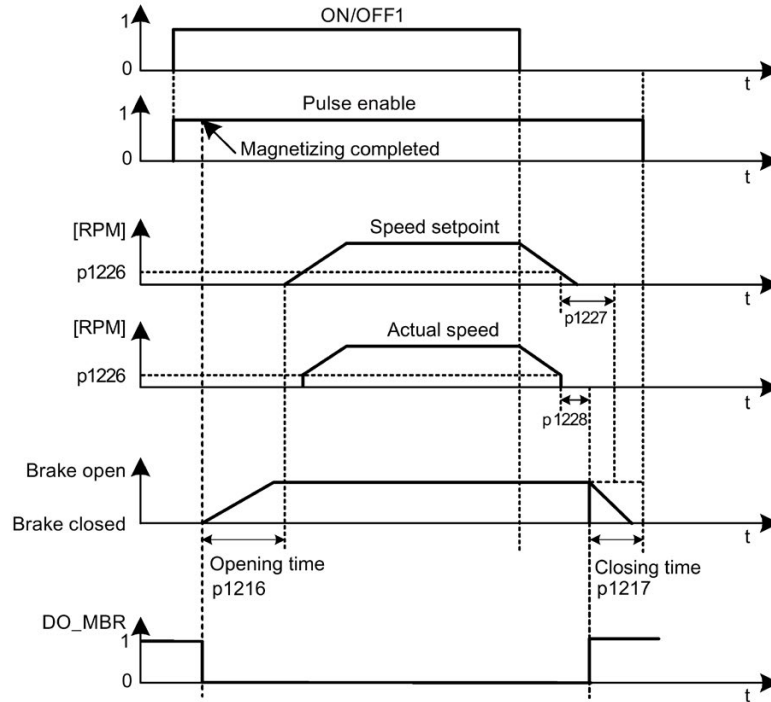

The start of the closing time for the brake depends on the expiration of the shorter of p1227 (zero speed detection monitoring time) and p1228 (pulse suppression delay time).

## 4.8 RS485 interface - X12

The SINAMICS V90 servo drives support communication with the PLCs through the RS485 interface over the USS or Modbus protocol.

### Pin assignment

Illustration	Pin	Signal name	Description
	1	Reserved	Do not use
	2	Reserved	Do not use
	3	RS485+	RS485 differential signal
	4	Reserved	Do not use
	5	M	Ground to internal 3.3 V
	6	3.3 V	3.3 V power supply for internal signal
	7	Reserved	Do not use
	8	RS485-	RS485 differential signal
	9	Reserved	Do not use

Type: 9-pin, Sub-D, female

# Commissioning

## 5.1 General commissioning information

Prior to commissioning, read "Basic operator panel (BOP) (Page 162)" for more information about the BOP operations. In case of any faults or alarms during commissioning, refer to Chapter "Diagnostics (Page 350)" for detailed description.

### CAUTION

#### **Danger to injury resulting from failure to observe the safety instructions**

Failure to observe the instructions can result in serious injuries.

- Before your commissioning or operation, read the safety instructions in Chapter "Fundamental safety instructions (Page 11)" carefully.

### WARNING

#### **Material damages and personal injuries by the drop of a hanging axis**

When the servo system is used as a hanging axis, the axis will drop if the positive and negative poles of the 24 V power supply are connected inversely. Unexpected drop of the hanging axis may cause material damages and personal injuries.

- Before commissioning, you need to make sure that a crosstie is used to hold the hanging axis in prevention of an unexpected drop. In addition, make sure that the 24 V power supply is correctly connected.

### NOTICE

#### **Firmware damage due to drive power-off during data transfer**

Switching off the 24 VDC power supply for the drive during data transfer from the micro SD card/SD card to the drive can cause damage to the drive firmware.

- Do not switch off the drive power supply when the data transfer from the micro SD card/SD card to the drive is in process.

**NOTICE**

**Existing setting data is overwritten by the setting data on the micro SD card/SD card during the drive startup**

Existing setting data is overwritten by the setting data on the micro SD card/SD card during the drive startup. This situation occurs when a drive is switched on with a micro SD card/SD card containing user setting data, the existing setting data on the drive will be overwritten, or when a drive is switched on with a micro SD card/SD card containing no user setting data, the drive will automatically save the existing user setting data onto the micro SD card/SD card.

- Before starting up the drive with a micro SD card/SD card, check whether the micro SD card/SD card contains user setting data. Otherwise, the existing data on the drive may be overwritten.

---

**Note**

**Plugging or unplugging the micro SD card/SD card will cause startup failure.**

Do not plug or unplug the micro SD card/SD card during startup; otherwise, the drive will fail to start up.

---

**Note**

In S control mode, if the motor shaft is blocked, the blocked torque is the current effective torque. Long time shaft blocking can cause damage to the motor.

---

## Engineering tool - SINAMICS V-ASSISTANT

You can use the engineering tool SINAMICS V-ASSISTANT to perform the trial operation.

SINAMICS V-ASSISTANT is a software tool that can be installed on a PC and runs on the Windows operating system. It communicates with the SINAMICS V90 servo drive with a USB cable (To ensure the stability of online commissioning, Siemens recommends you to use a shielded USB cable of no longer than 3 m with ferrite cores on both ends.). With SINAMICS V-ASSISTANT, you can change drive parameters and monitor drive working states in online mode.

For more information, refer to the SINAMICS V-ASSISTANT Online Help. You can search and download SINAMICS V-ASSISTANT from Technical support website (<https://support.industry.siemens.com/cs/ww/en/>).

## 5.2 Initial commissioning in JOG mode

### Commissioning purpose

When the servo drive is powered on for the first time, you can perform a test run with the BOP or the engineering tool SINAMICS V-ASSISTANT to check:

- Whether the line supply has been connected correctly
- Whether the 24 VDC power supply has been connected correctly
- Whether the cables (power cable, encoder cable, and brake cable) between the servo drive and the servo motor have been connected correctly
- Whether the motor speed and direction of rotation are correct.

### Prerequisites

- The servo drive is connected to the servo motor without load.
- No PLC is connected to the drive system.

### Operating sequence

#### Note

The digital signal EMGS **must** be kept at a high level (1) to ensure normal operation.

Step	Description	Remarks
1	Connect necessary units and check wiring.	<p>It is necessary to connect the following cables:</p> <ul style="list-style-type: none"> <li>• Power cable</li> <li>• Encoder cable</li> <li>• Brake cable</li> <li>• Line supply cable</li> <li>• 24 VDC cable</li> </ul> <p>Check:</p> <ul style="list-style-type: none"> <li>• Is the device or cable damaged?</li> <li>• Do the connected cables have excessive pressure, load or tension?</li> <li>• Are the connected cables put on sharp edges?</li> <li>• Is the line supply within the permissible range?</li> <li>• Are all the terminals firmly and correctly connected?</li> <li>• Are all the connected system components well grounded?</li> </ul> <p>Refer to "Connecting (Page 92)".</p>
2	Switch on the 24 VDC power supply.	

Step	Description	Remarks
3	<p>Check the servo motor type.</p> <ul style="list-style-type: none"> <li>If the servo motor has an incremental encoder, input the motor ID (p29000).</li> <li>If the servo motor has an absolute encoder, the servo drive can identify the servo motor automatically.</li> </ul>	<p>Fault <b>F52984</b> occurs when the servo motor is not identified. You can find the motor ID from the motor rating plate. Go to "Motor components (Page 26)" for detailed descriptions about motor rating plate.</p> <p>Refer to "Basic operations (Page 169)" for information about how to change a parameter with the BOP.</p>
4	<p>Check the direction of motor rotation.</p> <p>The default direction of rotation is CW (clockwise). You can change it by setting the parameter p29001 if necessary.</p>	<ul style="list-style-type: none"> <li>p29001 = 0: CW (default)</li> <li>p29001 = 1: CCW</li> </ul>
5	<p>Check the Jog speed.</p> <p>The default Jog speed is 100 rpm. You can change it by setting the parameter p1058.</p>	
6	<p>Save parameters with the BOP.</p>	<p>For detailed information about the parameter saving with the BOP, refer to "Saving parameters (RAM to ROM) (Page 175)".</p>
7	<p>Switch on the line supply.</p>	
8	<p>Clear faults and alarms.</p>	<p>Refer to "Diagnostics (Page 350)".</p>
9	<p>For the BOP, enter the <b>Jog</b> menu function and press the <b>UP</b> or <b>DOWN</b> button to run the servo motor.</p> <p>For the engineering tool, use the Jog function to run the servo motor.</p>	<p>For more information about Jog with the BOP, see Section "JOG (Page 174)".</p> <p>For more information about Jog with SINAMICS V-ASSISTANT, see SINAMICS V-ASSISTANT Online Help.</p>

**Note**

When you run the servo motor with an incremental encoder in JOG mode, the servo motor makes a short buzzing sound indicating that it is identifying the magnetic pole position of the rotor.



## 5.3 Commissioning in pulse train position control mode (PTI)

Step	Description	Comment
1	Switch off the line supply.	
2	Power off the servo drive and connect it to the controller (for example, SIMATIC S7-200 SMART) with the signal cable.	The digital signals CWL, CCWL and EMGS <b>must</b> be kept at high level (1) to ensure normal operation. Refer to "Standard application wiring (factory setting) (Page 119)" and "Connection examples with PLCs (Page 126)".
3	Switch on the 24 VDC power supply.	
4	Check the servo motor type. <ul style="list-style-type: none"> <li>If the servo motor has an incremental encoder, input the motor ID (p29000).</li> <li>If the servo motor has an absolute encoder, the servo drive can identify the servo motor automatically.</li> </ul>	Fault <b>F52984</b> occurs when the servo motor is not identified. You can find the motor ID from the motor rating plate. Go to "Motor components (Page 26)" for detailed descriptions about motor rating plate. Refer to "Basic operations (Page 169)" for information about how to change a parameter with the BOP.
5	Check the current control mode by viewing value of the parameter p29003. Pulse train input position control mode (p29003=0) is the factory setting of SINAMICS V90 servo drives.	Refer to "Compound controls (Page 181)".
6	Save the parameter and restart the servo drive to apply the setting of the pulse train input position control mode.	
7	Select a setpoint pulse train input form by setting parameter p29010.	<ul style="list-style-type: none"> <li>p29010 = 0 (default): pulse + direction, positive logic</li> <li>p29010 = 1: AB track, positive logic</li> <li>p29010 = 2: pulse + direction, negative logic</li> <li>p29010 = 3: AB track, negative logic</li> </ul> Refer to "Selecting a setpoint pulse train input form (Page 193)".
8	Select a pulse input channel by setting parameter p29014.	<ul style="list-style-type: none"> <li>p29014 = 0: high-speed 5 V differential pulse train input (RS485)</li> <li>p29014 = 1 (default): 24 V single end pulse train input</li> </ul> Refer to "Selecting a setpoint pulse train input channel (Page 192)".
9	Set the electronic gear ratio.	<p>You can use one of the following three methods to set the electronic gear ratio:</p> <ul style="list-style-type: none"> <li>Set the electronic gear ratio with parameters p29012 and p29013. <ul style="list-style-type: none"> <li>p29012: numerator of the electronic gear. Four numerators in total (p29012[0] to p29012[3]) are available.</li> <li>p29013: denominator of the electronic gear.</li> </ul> </li> <li>Set the setpoint pluses per revolution. <ul style="list-style-type: none"> <li>p29011: number of setpoint pulses per revolution.</li> </ul> </li> <li>Calculate the electronic gear ratio by selecting mechanical structure. <ul style="list-style-type: none"> <li>For more information, see SINAMICS V90 V-ASSISTANT Online Help.</li> </ul> </li> </ul> Refer to "Electronic gear ratio (Page 195)".

5.4 Commissioning in internal position control mode (IPos)

Step	Description	Comment
10	Set the torque limitation and speed limitation.	Refer to "Torque control (T) (Page 232)" and "Speed control (S) (Page 226)".
11	Configure necessary digital input signals by setting the following parameters: <ul style="list-style-type: none"> <li>• p29301[0]: DI1</li> <li>• p29302[0]: DI2</li> <li>• p29303[0]: DI3</li> <li>• p29304[0]: DI4</li> <li>• p29305[0]: DI5</li> <li>• p29306[0]: DI6</li> <li>• p29307[0]: DI7</li> <li>• p29308[0]: DI8</li> </ul>	The factory settings are: <ul style="list-style-type: none"> <li>• p29301[0]: 1 (SON)</li> <li>• p29302[0]: 2 (RESET)</li> <li>• p29303[0]: 3 (CWL)</li> <li>• p29304[0]: 4 (CCWL)</li> <li>• p29305[0]: 5 (G-CHANGE)</li> <li>• p29306[0]: 6 (P-TRG)</li> <li>• p29307[0]: 7 (CLR)</li> <li>• p29308[0]: 10 (TLIM1)</li> </ul> Refer to "Digital inputs/outputs (DIs/DOs) (Page 106)".
12	Check the encoder type. If it is an absolute encoder, adjust the absolute encoder with the BOP menu function "ABS".	Refer to "Adjusting an absolute encoder (Page 180)".
13	Set the pulse train encoder output.	Refer to "PTO function (Page 204)".
14	Save parameters with the BOP.	
15	Switch on the line supply.	
16	Clear faults and alarms.	Refer to "Diagnostics (Page 350)".
17	Trigger SON to the high level, input the setpoint pulse train from the command device, and then the servo motor starts running.	Use a low pulse frequency at first to check the direction and speed of rotation.
18	The system commissioning in pulse train input position control mode ends.	You can check the system performance. If it is not satisfied, you can adjust it. Refer to "Tuning (Page 284)".

## 5.4 Commissioning in internal position control mode (IPos)

Step	Description	Remarks
1	Switch off the line supply.	
2	Power off the servo drive and connect it to the controller (for example, SIMATIC S7-200 SMART) with the signal cable.	The digital signals CWL, CCWL and EMGS <b>must</b> be kept at high level (1) to ensure normal operation. Refer to "Standard application wiring (factory setting) (Page 119)" and "Connection examples with PLCs (Page 126)".
3	Switch on the 24 VDC power supply.	
4	Check the servo motor type. <ul style="list-style-type: none"> <li>• If the servo motor has an incremental encoder, input the motor ID (p29000).</li> <li>• If the servo motor has an absolute encoder, the servo drive can identify the servo motor automatically.</li> </ul>	Fault <b>F52984</b> occurs when the servo motor is not identified. You can find the motor ID from the motor rating plate. For the detailed information of the motor rating plate, see Section "Motor components (Page 26)". Refer to "Basic operations (Page 169)" for information about how to change a parameter with the BOP.

Step	Description	Remarks
5	Switch to the internal position control mode by setting parameter p29003 = 1.	Refer to "Compound controls (Page 181)".
6	Save the parameter and restart the servo drive to apply the setting of the internal position control mode.	
7	Set the mechanical gear ratio with parameters p29247, p29248 and p29249.	<ul style="list-style-type: none"> <li>• p29247: LU per load revolution</li> <li>• p29248: load revolutions</li> <li>• p29249: motor revolutions</li> </ul> Refer to "Setting mechanical system (Page 206)".
8	Select the axis type by setting parameter p29245. If you use the modular axis, you need to define the modular range by setting parameter p29246.	<ul style="list-style-type: none"> <li>• p29245 = 0: linear axis</li> <li>• p29245 = 1: modular axis</li> </ul> Refer to "Configuring the linear/modular axis (Page 210)".
9	Check and select a positioning mode by setting parameter p29241.	For a linear axis, there are two positioning modes: <ul style="list-style-type: none"> <li>• p29241 = 0: incremental</li> <li>• p29241 = 1: absolute</li> </ul> For modular axis, there are four positioning modes: <ul style="list-style-type: none"> <li>• p29241 = 0: incremental</li> <li>• p29241 = 1: absolute</li> <li>• p29241 = 2: absolute, positive (only for a rotary axis with modulo correction)</li> <li>• p29241 = 3: absolute, negative (only for a rotary axis with modulo correction)</li> </ul> Refer to "Selecting a positioning mode - absolute/incremental (Page 209)".
10	Configure the fixed position setpoint (p2617[0] to p2617[7] and p2618[0] to p2618[7]) according to mechanism.	Refer to "Setting fixed position setpoint (Page 207)".
11	Set the torque limitation and speed limitation.	Refer to "Torque limit (Page 220)" and "Speed limit (Page 220)".
12	Configure necessary digital input signals by setting the following parameters: <ul style="list-style-type: none"> <li>• p29301[1]: DI1</li> <li>• p29302[1]: DI2</li> <li>• p29303[1]: DI3</li> <li>• p29304[1]: DI4</li> <li>• p29305[1]: DI5</li> <li>• p29306[1]: DI6</li> <li>• p29307[1]: DI7</li> <li>• p29308[1]: DI8</li> </ul>	The factory settings are: <ul style="list-style-type: none"> <li>• p29301[1]: 1 (SON)</li> <li>• p29302[1]: 2 (RESET)</li> <li>• p29303[1]: 3 (CWL)</li> <li>• p29304[1]: 4 (CCWL)</li> <li>• p29305[1]: 5 (G-CHANGE)</li> <li>• p29306[1]: 6 (P-TRG)</li> <li>• p29307[1]: 21 (POS1)</li> <li>• p29308[1]: 22 (POS2)</li> </ul> Refer to "Digital inputs/outputs (DIs/DOs) (Page 106)". <b>NOTE</b> You must configure the digital input signal REF or SREF according to your selection of referencing mode. Refer to "Referencing (Page 211)".

5.5 Commissioning in speed control mode (S)

Step	Description	Remarks
13	<p>Check the encoder type and perform referencing:</p> <ul style="list-style-type: none"> <li>For an incremental encoder, choose a referencing mode by setting parameter p29240 and perform referencing.</li> <li>For an absolute encoder, choose a referencing mode and adjust the encoder with the BOP menu function "ABS". Refer to "Adjusting an absolute encoder (Page 180)".</li> </ul>	<p>Five referencing modes are available:</p> <ul style="list-style-type: none"> <li>p29240 = 0: with digital input signal REF</li> <li>p29240 = 1 (default): external referencing cam (REF) and encoder zero mark</li> <li>p29240 = 2: only encoder zero mark</li> <li>p29240 = 3: external referencing cam (CCWL) and encoder zero mark</li> <li>p29240 = 4: external referencing cam (CWL) and encoder zero mark</li> </ul> <p>Refer to "Referencing (Page 211)".</p>
14	Set the pulse train encoder output.	Refer to "PTO function (Page 204)".
15	Save parameters with the BOP.	
16	Switch on the line supply.	
17	Clear faults and alarms.	Refer to "Diagnostics (Page 350)".
18	Trigger the digital signal SON to be high level.	
19	Select a fixed position setpoint by configuring the digital inputs POS1, POS2 and POS3, then start positioning with the triggering signal P-TRG.	<p>POS3 : POS2 : POS1</p> <p>0 : 0 : 0: fixed position setpoint 1 (p2617[0])</p> <p>0 : 0 : 1: fixed position setpoint 2 (p2617[1])</p> <p>0 : 1 : 0: fixed position setpoint 3 (p2617[2])</p> <p>0 : 1 : 1: fixed position setpoint 4 (p2617[3])</p> <p>1 : 0 : 0: fixed position setpoint 5 (p2617[4])</p> <p>1 : 0 : 1: fixed position setpoint 6 (p2617[5])</p> <p>1 : 1 : 0: fixed position setpoint 7 (p2617[6])</p> <p>1 : 1 : 1: fixed position setpoint 8 (p2617[7])</p> <p>Refer to "Selecting a fixed position setpoint and starting positioning (Page 220)".</p>
20	The system commissioning in internal position control mode ends.	You can check the system performance. If it is not satisfied, you can adjust it. Refer to "Tuning (Page 284)".

5.5 Commissioning in speed control mode (S)

Step	Description	Remarks
1	Switch off the line supply.	
2	Power off the servo drive and connect it to the controller (for example, SIMATIC S7-200 SMART) with the signal cable.	<p>The digital signals CWL, CCWL and EMGS <b>must</b> be kept at high level (1) to ensure normal operation.</p> <p>Refer to "Standard application wiring (factory setting) (Page 119)" and "Connection examples with PLCs (Page 126)".</p>
3	Switch on the 24 VDC power supply.	

Step	Description	Remarks
4	<p>Check the servo motor type.</p> <ul style="list-style-type: none"> <li>If the servo motor has an incremental encoder, input the motor ID (p29000).</li> <li>If the servo motor has an absolute encoder, the servo drive can identify the servo motor automatically.</li> </ul>	<p>Fault <b>F52984</b> occurs when the servo motor is not identified.</p> <p>You can find the motor ID from the motor rating plate. Go to "Motor components (Page 26)" for detailed descriptions about motor rating plate.</p> <p>Refer to "Basic operations (Page 169)" for information about how to change a parameter with the BOP.</p>
5	Switch to the speed control mode by setting p29003 = 2.	Refer to "Compound controls (Page 181)".
6	Save the parameter and restart the servo drive to apply the setting of the speed control mode.	
7	Configure speed setpoint.	<p>You can select the external analog speed setpoint or one of seven fixed speed setpoints by configuring the digital signals SPD3, SPD2 and SPD1.</p> <p>SPD3 : SPD2 : SPD1</p> <p>0 : 0 : 0: external analog speed setpoint (analog input 1)</p> <p>0 : 0 : 1: fixed speed setpoint 1 (p1001)</p> <p>0 : 1 : 0: fixed speed setpoint 2 (p1002)</p> <p>0 : 1 : 1: fixed speed setpoint 3 (p1003)</p> <p>1 : 0 : 0: fixed speed setpoint 4 (p1004)</p> <p>1 : 0 : 1: fixed speed setpoint 5 (p1005)</p> <p>1 : 1 : 0: fixed speed setpoint 6 (p1006)</p> <p>1 : 1 : 1: fixed speed setpoint 7 (p1007)</p> <p>Refer to "Configuring speed setpoint (Page 226)".</p>
8	If the external analog speed setpoint is used, configure the maximum analog speed setpoint corresponding to 10 V by setting parameter p29060.	
9	Set the torque limitation and speed limitation.	Refer to "Torque limit (Page 229)" and "Speed limit (Page 229)".
10	<p>Configure necessary digital input signals by setting the following parameters:</p> <ul style="list-style-type: none"> <li>p29301[2]: DI1</li> <li>p29302[2]: DI2</li> <li>p29303[2]: DI3</li> <li>p29304[2]: DI4</li> <li>p29305[2]: DI5</li> <li>p29306[2]: DI6</li> <li>p29307[2]: DI7</li> <li>p29308[2]: DI8</li> </ul>	<p>The factory settings are:</p> <ul style="list-style-type: none"> <li>p29301[2]: 1 (SON)</li> <li>p29302[2]: 2 (RESET)</li> <li>p29303[2]: 3 (CWL)</li> <li>p29304[2]: 4 (CCWL)</li> <li>p29305[2]: 12 (CWE)</li> <li>p29306[2]: 13 (CCWE)</li> <li>p29307[2]: 15 (SPD1)</li> <li>p29308[2]: 16 (SPD2)</li> </ul> <p>Refer to "Digital inputs/outputs (DIs/DOs) (Page 106)".</p>
11	Save parameters with the BOP.	
12	Switch on the line supply.	
13	Clear faults and alarms.	Refer to "Diagnostics (Page 350)".

5.6 Commissioning in torque control mode (T)

Step	Description	Remarks
14	Enable the CWE or CCWE and change SON status to be high level (1) then the servo motor starts running according to configured speed setpoint.	The actual speed of the servo motor can be viewed from the BOP operating display. The default display is the actual speed. You can change the display by setting the parameter p29002. Refer to "Actual status display (Page 168)".
15	The system commissioning in speed control mode ends.	You can check the system performance. If it is not satisfied, you can adjust it. Refer to "Tuning (Page 284)".

## 5.6 Commissioning in torque control mode (T)

Step	Description	Remarks
1	Switch off the line supply.	
2	Power off the servo drive and connect it to the controller (for example, SIMATIC S7-200 SMART) with the signal cable.	The digital signals CWL, CCWL and EMGS <b>must</b> be kept at high level (1) to ensure normal operation. Refer to "Standard application wiring (factory setting) (Page 119)" and "Connection examples with PLCs (Page 126)".
3	Switch on the 24 VDC power supply.	
4	Check the servo motor type. <ul style="list-style-type: none"> <li>If the servo motor has an incremental encoder, input the motor ID (p29000).</li> <li>If the servo motor has an absolute encoder, the servo drive can identify the servo motor automatically.</li> </ul>	Fault <b>F52984</b> occurs when the servo motor is not identified. You can find the motor ID from the motor rating plate. Go to "Motor components (Page 26)" for detailed descriptions about motor rating plate. Refer to "Basic operations (Page 169)" for information about how to change a parameter with the BOP.
5	Switch to the torque control mode by setting p29003 = 3.	Refer to "Compound controls (Page 181)".
6	Save the parameter and restart the servo drive to apply the setting of the torque control mode.	
7	Select torque setpoint by configuring the digital input signal TSET.	<ul style="list-style-type: none"> <li>TSET = low level (0): external analog torque setpoint (analog input 2)</li> <li>TSET = high level (1): fixed torque setpoint</li> </ul>
8	If the fixed torque setpoint is used, input your desired torque setpoint value and offset value into parameter p29043 and p29042.	Refer to "Torque control with fixed torque setpoint (Page 234)".
9	If the external analog torque setpoint is used, configure the scaling (percentage of the rated torque) for analog torque setpoint corresponding to 10 V by setting parameter p29041[0].	Refer to "Torque control with external analog torque setpoint (Page 233)".
10	Set the speed limitation.	Refer to "Speed limit (Page 234)".

Step	Description	Remarks
11	Configure necessary digital input signals by setting the following parameters: <ul style="list-style-type: none"> <li>• p29301[3]: DI1</li> <li>• p29302[3]: DI2</li> <li>• p29303[3]: DI3</li> <li>• p29304[3]: DI4</li> <li>• p29305[3]: DI5</li> <li>• p29306[3]: DI6</li> <li>• p29307[3]: DI7</li> <li>• p29308[3]: DI8</li> </ul>	The factory settings are: <ul style="list-style-type: none"> <li>• p29301[3]: 1 (SON)</li> <li>• p29302[3]: 2 (RESET)</li> <li>• p29303[3]: 3 (CWL)</li> <li>• p29304[3]: 4 (CCWL)</li> <li>• p29305[3]: 12 (CWE)</li> <li>• p29306[3]: 13 (CCWE)</li> <li>• p29307[3]: 18 (TSET)</li> <li>• p29308[3]: 19 (SLIM1)</li> </ul> Refer to "Digital inputs/outputs (DIs/DOs) (Page 106)".
12	Save parameters with the BOP.	
13	Switch on the line supply.	
14	Clear faults and alarms.	Refer to "Diagnostics (Page 350)".
15	Enable the CWE or CCWE and Change SON status to be high level (1) then the servo motor starts running according to configured torque setpoint.	The actual torque of the servo motor can be viewed from the BOP operating display. The default display is actual speed. You can change it by setting p29002 = 2. Refer to "Actual status display (Page 168)".
16	The system commissioning in torque control mode ends.	You can check the system performance. If it is not satisfied, you can adjust it. Refer to "Tuning (Page 284)".

## Basic operator panel (BOP)

### 6.1 BOP overview

The SINAMICS V90 servo drive is designed with a Basic Operator Panel (BOP) on the front panel of the servo drive.

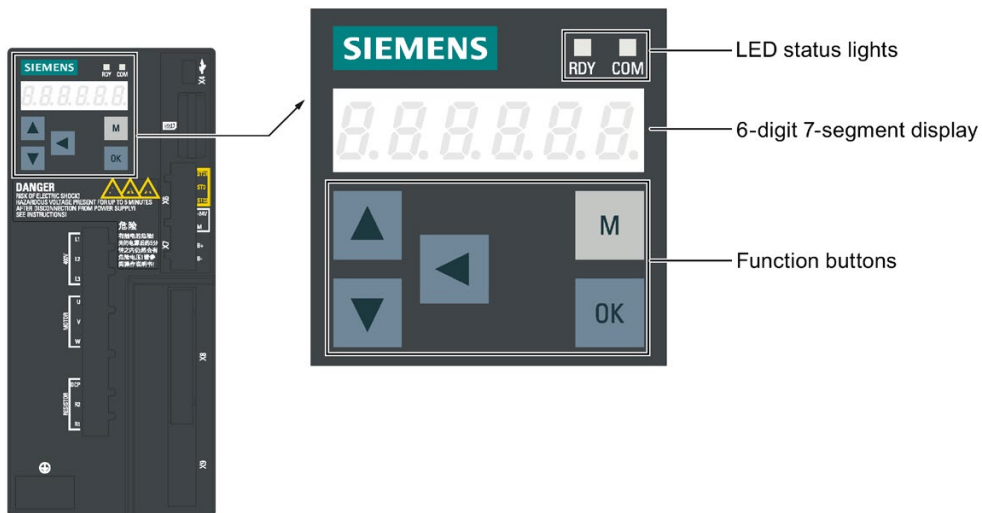

You can use the BOP for the following operations:

- Standalone commissioning
- Diagnosis
- Parameter access
- Parameter settings
- Micro SD card/SD card operations
- Drive restart



### 6.1.1 LED status indicators

Two LED status indicators (RDY and COM) are available to indicate drive status. Both LEDs are dual color (green/red).

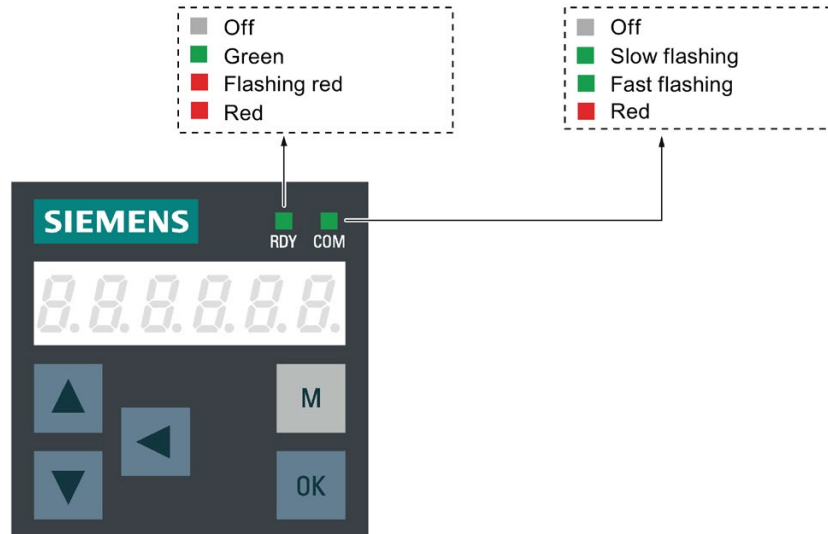











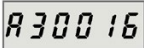
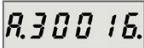





You can find detailed information about the status indications in the table below:











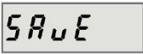





Status indicator	Color	Status	Description
RDY	-	Off	24 V control board power supply is missing
	Green	Continuously lit	The drive is in "S ON" state
	Red	Continuously lit	The drive is in "S OFF" state or in startup state
		Flash at 1 Hz	Alarms or faults occurs
COM	-	Off	Communication with PC is not active
	Green	Flash at 0.5 Hz	Communication with PC is active
		Flash at 2 Hz	Micro SD card/SD card operating (read or write)
	Red	Continuously lit	Communication with PC is in error

### 6.1.2 BOP display

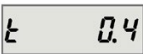
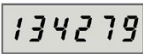

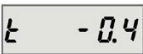
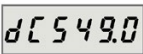





Display	Example	Description	Remarks
8.8.8.8.8.8.		Drive is in startup state	
-----		Drive is busy	
Fxxxxx		Fault code	In the case of a single fault
F.xxxxx.		Fault code of the first fault	In the case of multiple faults

## 6.1 BOP overview

Display	Example	Description	Remarks
Fxxxx.		Fault code	In the case of multiple faults
Axxxxx		Alarm code	In the case of a single alarm
A.xxxxx.		Alarm code of the first alarm	In the case of multiple alarms
Axxxxx.		Alarm code	In the case of multiple alarms
Rxxxxx		Parameter number	Read-only parameter
Pxxxxx		Parameter number	Editable parameter
P.xxxxx		Parameter number	Editable parameter; the dot means that at least one parameter has been changed
In xx		Indexed parameter	Figure after "In" indicates the number of indices. For example, "In 01" means that this indexed parameter is 1.
xxx.xxx		Negative parameter value	
xxx.xx<>		Current display can be moved to left or right	
xxxx.xx>		Current display can be moved to right	
xxxx.xx<		Current display can be moved to left	
S Off		Operating display: servo off	
Para		Editable parameter group	Refer to the section "Editing parameters (Page 170)".
P xxx		Parameter group	Six groups are available: 1. P 0A: basic 2. P 0B: gain adjustment 3. P 0C: speed control 4. P 0D: torque control 5. P 0E: position control 6. P 0F: I/O 7. P ALL: all parameters
Data		Read-only parameter group	Refer to "Viewing parameters (Page 172)".
Func		Function group	Refer to "Auxiliary functions (Page 173)".
Jog		Jog function	Refer to "JOG (Page 174)".

Display	Example	Description	Remarks
Save		Save data in drive	Refer to "Saving parameters (RAM to ROM) (Page 175)".
defu		Restore drive to default settings	Refer to "Setting parameters to default (Page 176)".
dr--sd		Save data from drive to micro SD card/SD card	Refer to "Transferring data (drive to SD) (Page 176)".
sd--dr		Upload data from micro SD card/SD card to drive	Refer to "Transferring data (SD to drive) (Page 177)".
Update		Update firmware	Refer to "Updating firmware (Page 178)".
A OFF1		Adjust AI1 offset	Refer to "Adjusting AI offsets (Page 179)".
A OFF2		Adjust AI2 offset	Refer to "Adjusting AI offsets (Page 179)".
ABS		The zero position has not been set	Refer to "Adjusting an absolute encoder (Page 180)".
A.B.S.		The zero position has been set	Refer to "Adjusting an absolute encoder (Page 180)".
r xxx		Actual speed (positive direction)	
r -xxx		Actual speed (negative direction)	
T x.x		Actual torque (positive direction)	
xxxxxx		Actual position (positive direction)	Only the last six digits displays due to a limited display length.
xxxxxx.		Actual position (negative direction)	Only the last six digits displays due to a limited display length.
T -x.x		Actual torque (negative direction)	
DCxxx.x		Actual DC link voltage	
Exxxxx		Position following error	
run		The motor is running	
Con		The communication between the SINAMICS V-ASSISTANT and the servo drive is established.	In this case, the BOP is protected from any operations except clearing alarms and acknowledging faults.

### 6.1.3 Control buttons

Button	Description	Functions
	M button	<ul style="list-style-type: none"> <li>Exits from the current menu</li> <li>Switches between operating modes in the top level menu</li> </ul>
	OK button	<p>Short-pressing:</p> <ul style="list-style-type: none"> <li>Confirms selection or input</li> <li>Enters sub menu</li> <li>Acknowledges faults</li> </ul> <p>Long-pressing:</p> <p>Activates auxiliary functions</p> <ul style="list-style-type: none"> <li>JOG</li> <li>Saves parameter set in drive (RAM to ROM)</li> <li>Sets parameter set to default</li> <li>Transfers data (drive to micro SD card/SD card)</li> <li>Transfers data (micro SD card/SD card to drive)</li> <li>Updates firmware</li> </ul>
	UP button	<ul style="list-style-type: none"> <li>Navigates to the next item</li> <li>Increases a value</li> <li>JOG in CW (clockwise)</li> </ul>
	DOWN button	<ul style="list-style-type: none"> <li>Navigates to the previous item</li> <li>Decreases a value</li> <li>JOG in CCW (counter-clockwise)</li> </ul>
	SHIFT button	<p>Moves the cursor from digit to digit for single digit editing, including the digit of positive/negative sign</p> <p><b>Note:</b> When the sign is edited, "_" indicates positive and "-" indicates negative.</p>
	Press the key combination for four seconds to restart the drive	
	Moves current display to the left page when $\text{r}$ is displayed at the upper right corner, for example $00.000\text{r}$ .	
	Moves current display to the right page when $\text{J}$ is displayed at the lower right corner, for example $00\ 10\text{J}$ .	

## 6.2 Parameter structure

The overall parameter structure of the BOP is designed as follows.

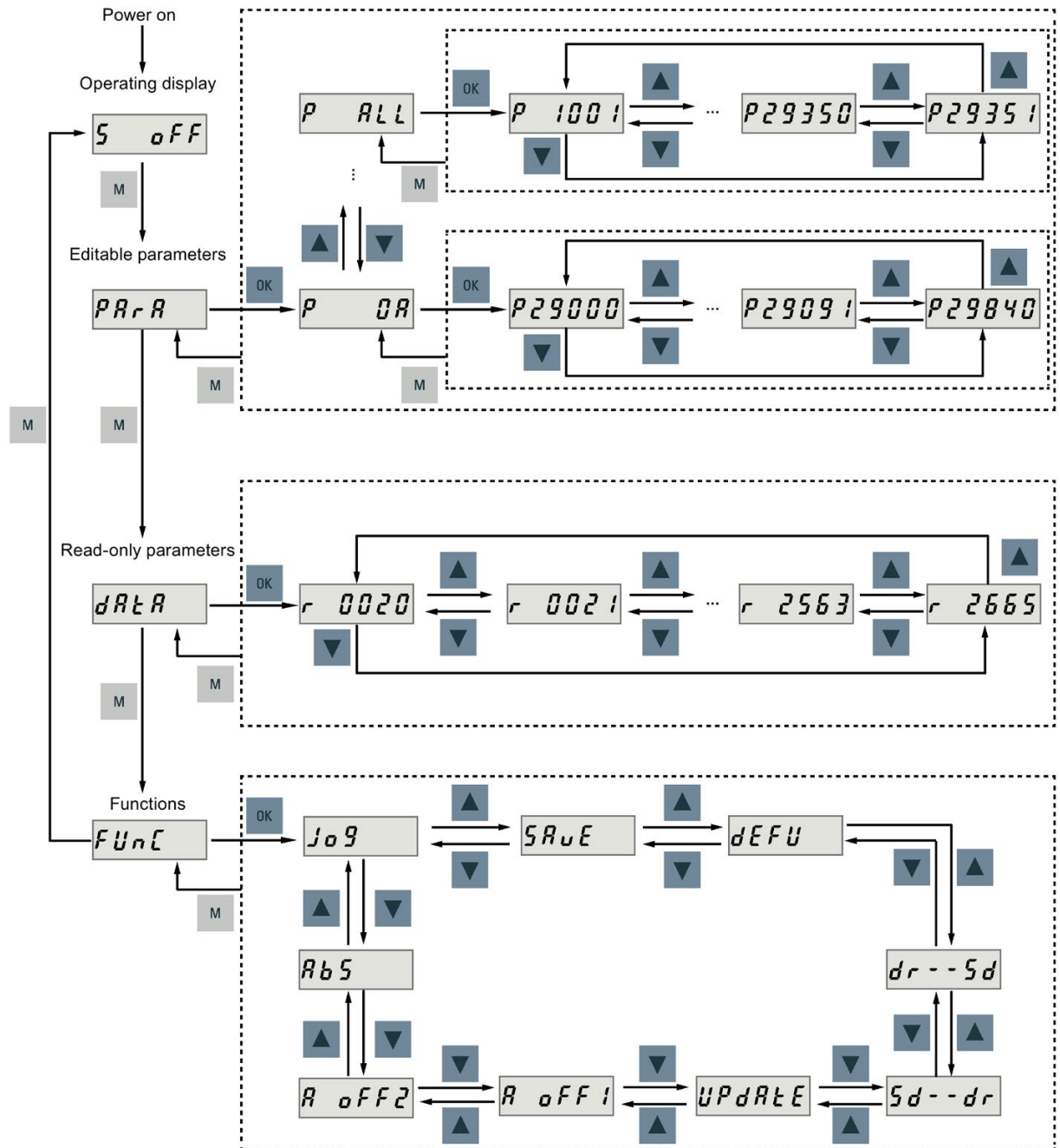

### Note

There is no ABS menu function for a servo motor with an incremental encoder.

The ABS menu function is **only** available for a servo motor with an absolute encoder.

## 6.3 Actual status display

The following drive states can be monitored using the operating panel after power-on:

- Servo off
- Actual speed
- Actual torque
- DC voltage
- Actual position
- Position following error

If servo enable signal is available, actual drive speed is displayed by default; otherwise, "S OFF" (servo off) is displayed.

With p29002, you define which of the following drive operating status data is to be displayed on the BOP.

Parameter	Range	Default	Unit	Description
p29002	0 to 4	0	-	<ul style="list-style-type: none"><li>• 0: Actual speed</li><li>• 1: DC voltage</li><li>• 2: Actual torque</li><li>• 3: Actual position</li><li>• 4: Position following error</li></ul>

---

### Note

Make sure you save p29002 after modification.

---

## 6.4 Basic operations

### Overview

- Editable parameters: all **P** parameters under the "**Para**" menu are settable parameters. Seven groups in total are available:
  - **P 0A**: basic
  - **P 0B**: gain adjustment
  - **P 0C**: speed control
  - **P 0D**: torque control
  - **P 0E**: position control
  - **P 0F**: I/O
  - **P All**: all parameters
- Read-only parameters: All **r** parameters under the "**Data**" menu are read-only parameters. You can only read values of these parameters.

### Parameters with index

Some parameters have several indices. Each index has its own meaning and corresponding value.

### Parameters without index

All parameters that do not have indices are parameters without index.

### 6.4.1 Editing parameters

You can edit a parameter value in two methods:

- Method 1: change the value directly with the UP or DOWN button

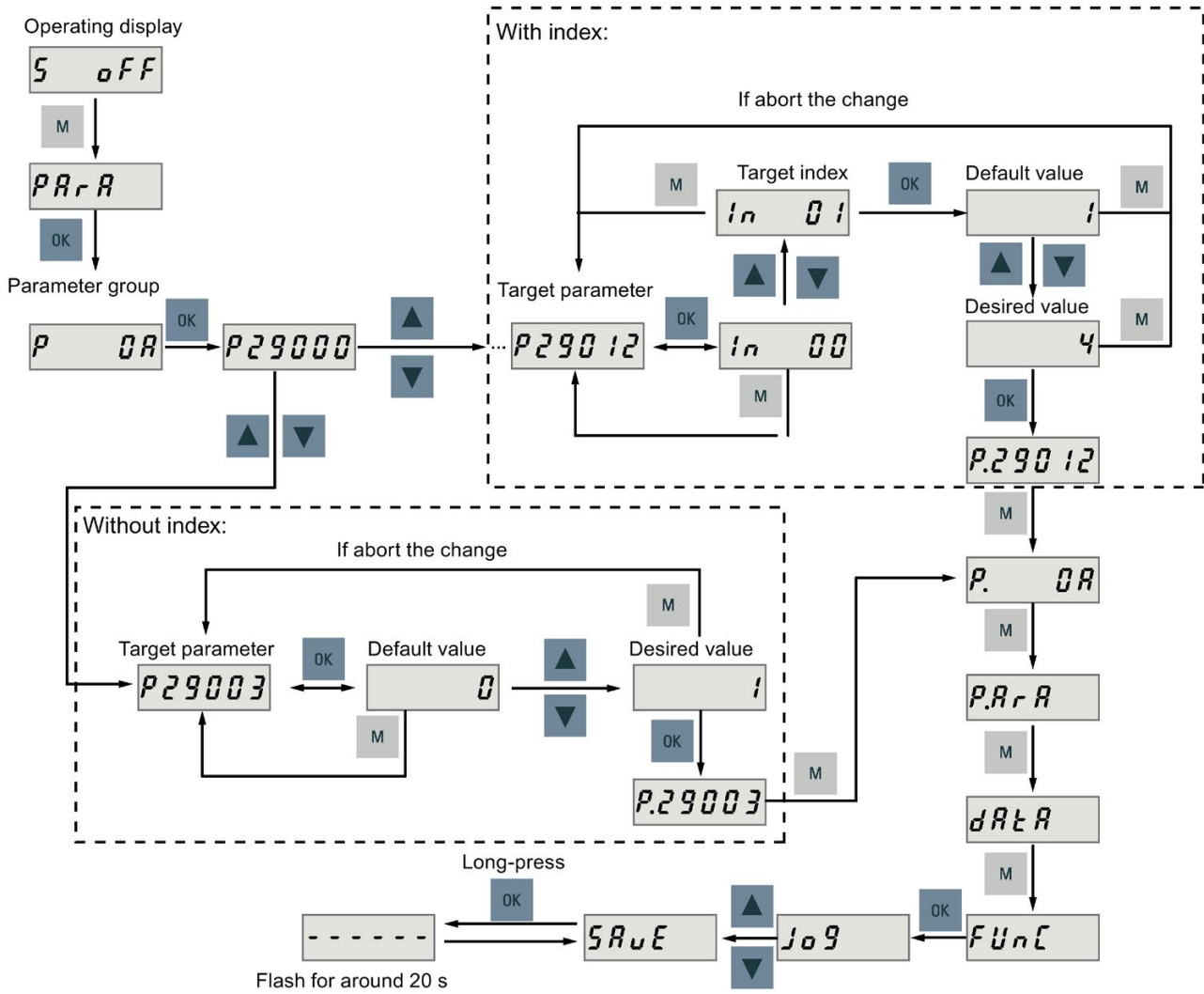



- Method 2: move the cursor to a digit with the **SHIFT** button, then change the digit value with the **UP** or **DOWN** button

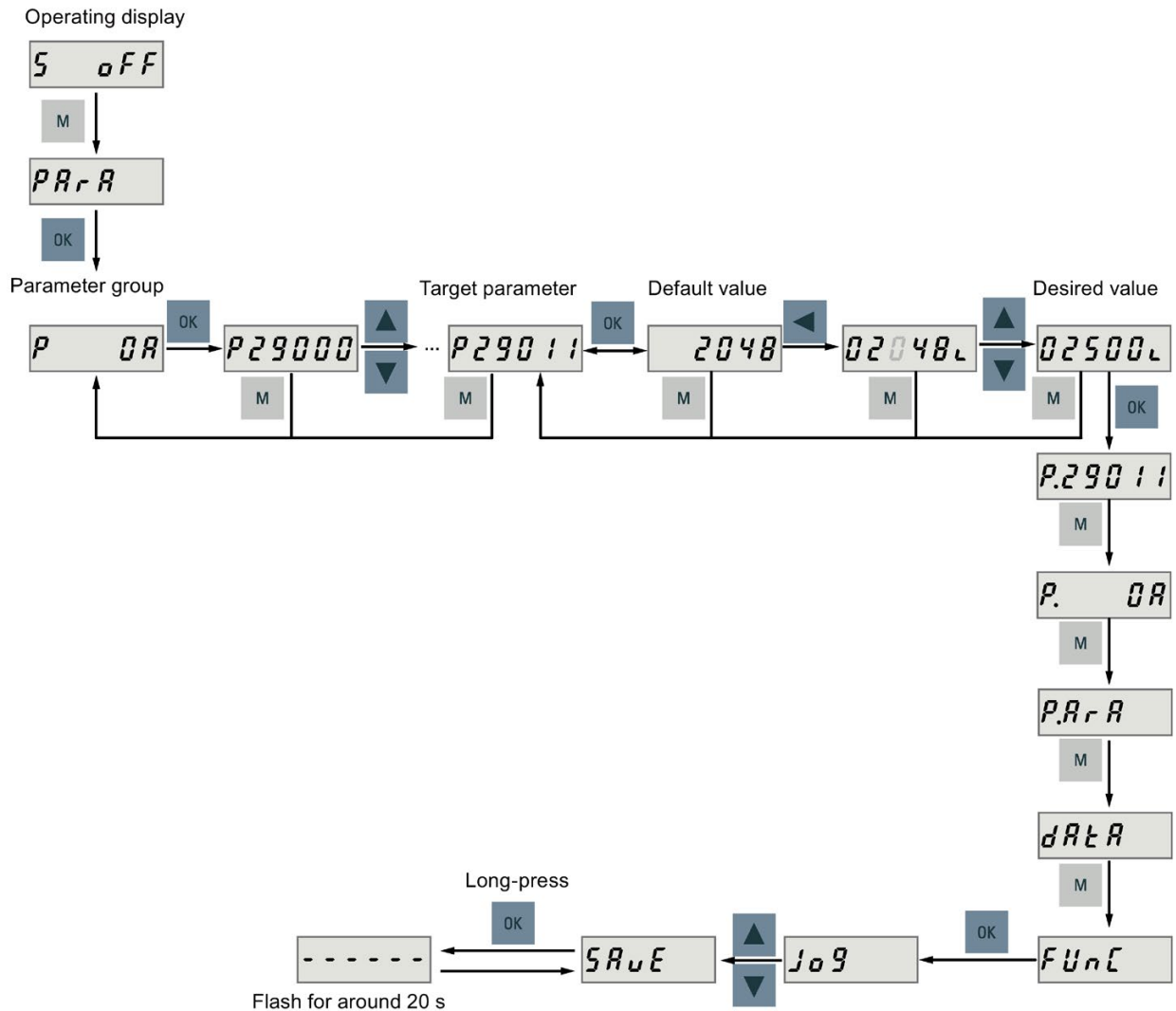

### Note

The parameters p1414 and p1656 cannot be changed using the **SHIFT** button.

### 6.4.2 Viewing parameters

To view a parameter, proceed as follows.

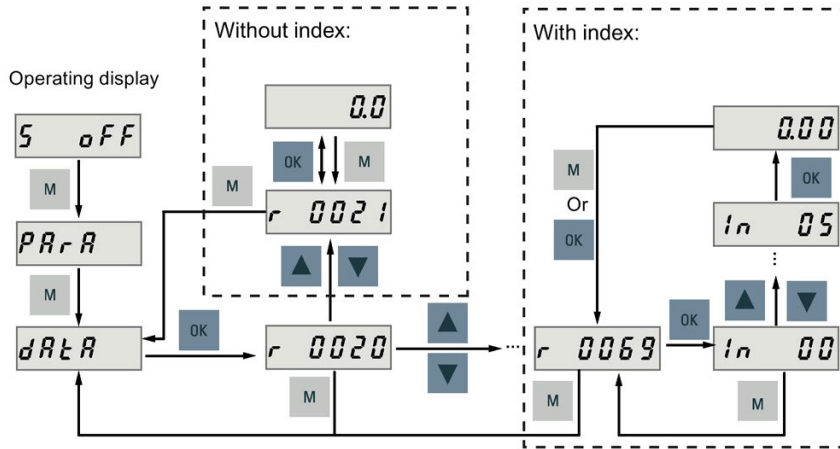

### 6.4.3 Searching parameters in "P ALL" menu

If you do not know which group that a parameter belongs to, you can search for in the "P ALL" menu.

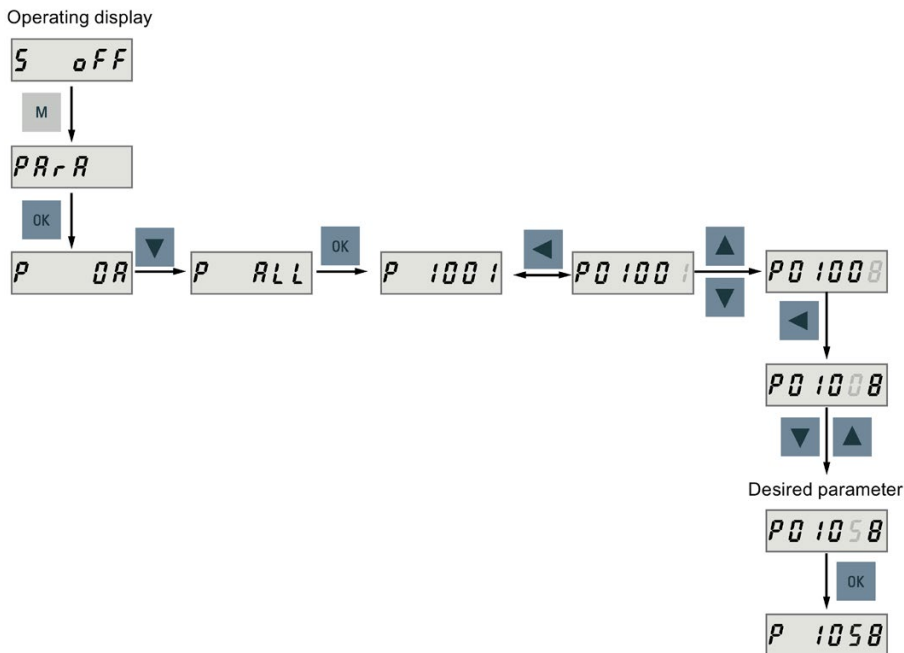

#### Note

##### Invalid parameter number

If the input parameter number is unavailable, the nearest parameter number to the input value is displayed.

## 6.5 Auxiliary functions

Totally, there are nine BOP functions available.

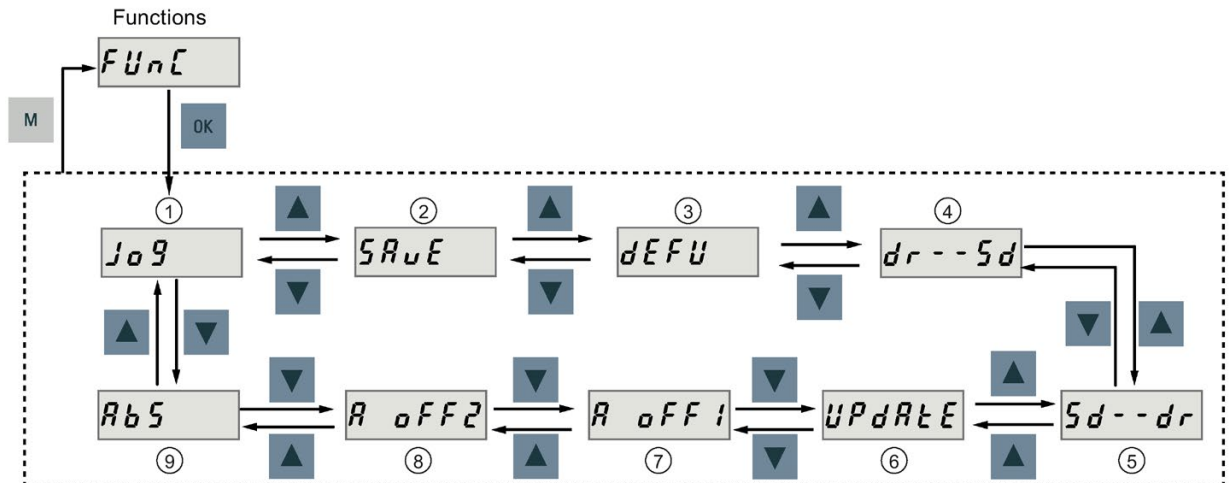

- |  |                           |
|--|---------------------------|
| ① Jog  | ⑥ Update firmware         |
| ② Save parameter set in drive                              | ⑦ Adjust AI1 offset       |
| ③ Restore parameter values to default                      | ⑧ Adjust AI2 offset       |
| ④ Copy parameter set from drive to a micro SD card/SD card | ⑨ Adjust absolute encoder |

**NOTE:**

This function is available only when the servo motor with an absolute encoder is connected.

- ⑤ Copy parameter set from a micro SD card/SD card to drive

### 6.5.1 JOG

**Note**

The digital signal EMGS **must** be kept at high level (1) to ensure normal operation.

With the Jog function, you can run the connected motor and view Jog speed or Jog torque.

**Jog in speed (example)**

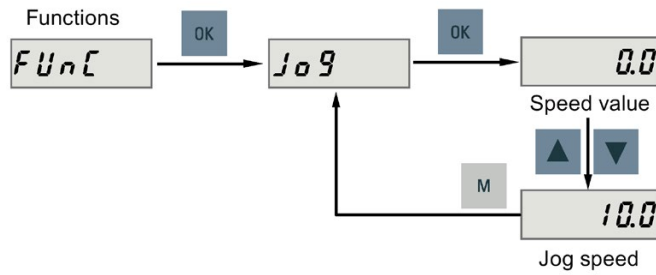

**Jog in torque (example)**

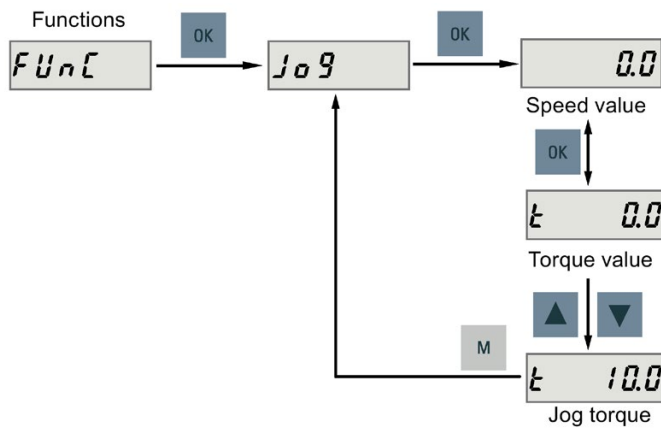

**NOTICE**

**Exit the Jog mode after completing Jog run.**

The servo motor cannot run if the servo drive is in the Jog mode.

## 6.5.2 Saving parameters (RAM to ROM)

This function is used for saving a parameter set from the drive RAM to drive ROM. To use this function, proceed as follows.

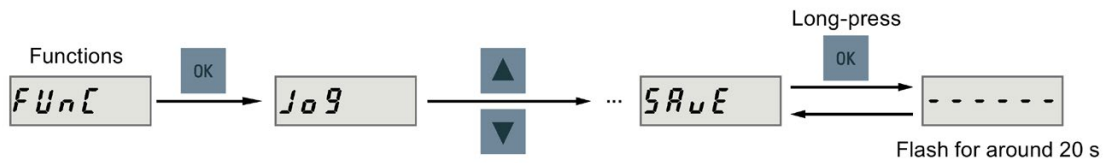

### Note

**Plugging or unplugging the micro SD card/SD card will cause saving failure.**

Do not plug or unplug the micro SD card/SD card during saving; otherwise, the saving operation will fail.

### Note

- If a micro SD card/SD card has been inserted, the parameter set will be saved onto the micro SD card/SD card simultaneously.
- All signal functions become inactive during the saving process. Use the signal functions afterwards.

## Reference

Editing parameters (Page 170)

### 6.5.3 Setting parameters to default

This function is used to reset all parameters to their default values. To use this function, proceed as follows.

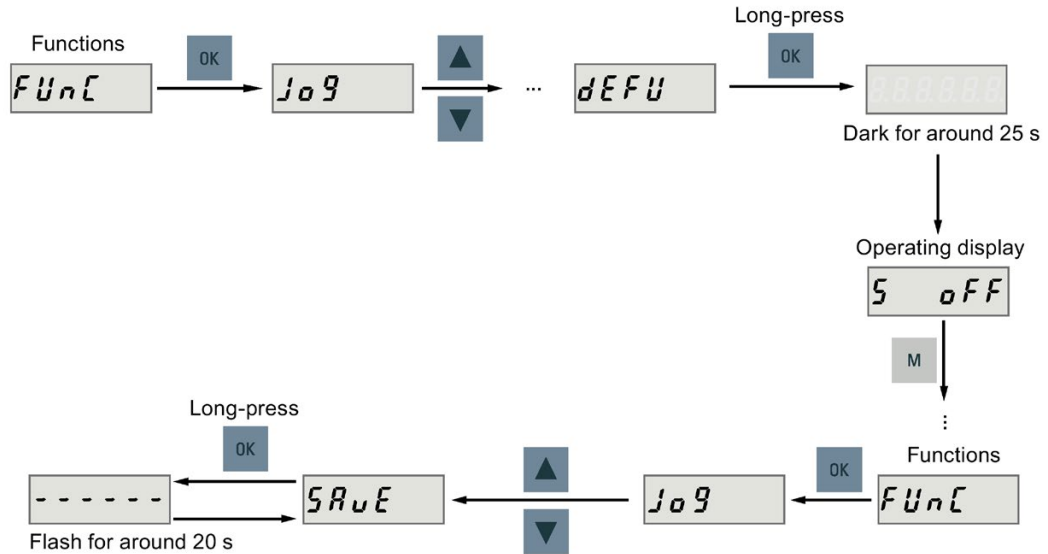

**Note**

You **must** save the parameter set after setting the parameter set to the default values; otherwise, the default values will not be saved to drive ROM.

**Reference**

Saving parameters (RAM to ROM) (Page 175)

### 6.5.4 Transferring data (drive to SD)

You can save the parameter set from the drive ROM to a micro SD card/SD card with the BOP. To do this, proceed as follows.

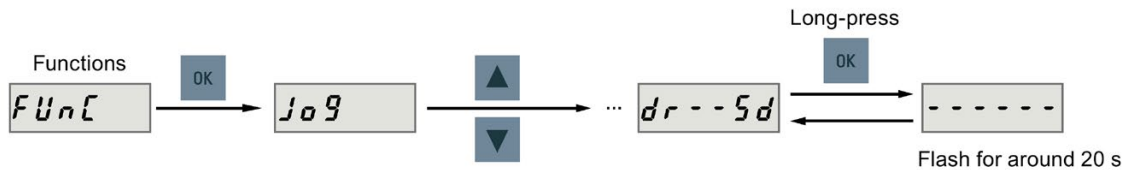

**Note**

Data transfer between the drive and the SD card is possible only when the drive is in "S OFF" state.

**Note**

**Plugging or unplugging the micro SD card/SD card will cause transferring failure.**

Do not plug or unplug the micro SD card/SD card during transferring; otherwise, the transferring operation will fail.

**Note**

Write protection function is not supported by SINAMICS V90. Data in the micro SD card/SD card will be overwritten even if the write protection function of the micro SD card/SD card is enabled.

### 6.5.5 Transferring data (SD to drive)

You can also upload the parameters from a micro SD card/SD card to the drive ROM. To do this, proceed as follows.

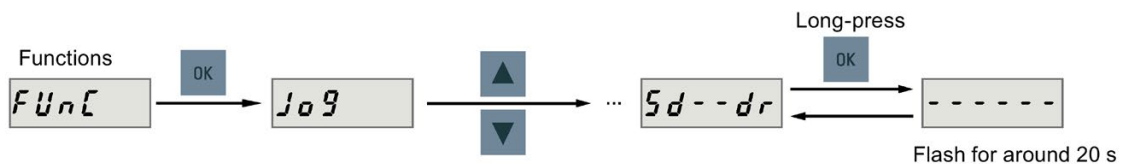
**Note**

Data transfer between the drive and the SD card is possible only when the drive is in "S OFF" state.

**Note**

**Plugging or unplugging the micro SD card/SD card will cause transferring failure.**

Do not plug or unplug the micro SD card/SD card during transferring; otherwise, the transferring operation will fail.

**Note****Parameter inconsistency**

If the parameters on the micro SD card/SD card are inconsistent with existing parameters in the drive memory, you **must** restart the servo drive to apply the changes.

### 6.5.6 Updating firmware

With the firmware update function of the BOP, you can update the drive firmware. To do this, you have to store proper firmware files on a micro SD card/SD card and insert it into the micro SD card/SD card slot. After that, proceed as follows.

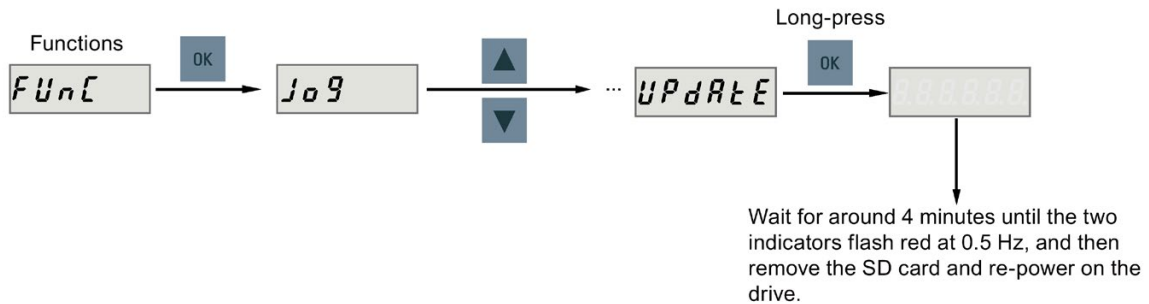

After you have updated the firmware, you need to set parameters to their default values. Refer to "Setting parameters to default (Page 176)" about the default process.

#### Note

Before updating the firmware, you can back up the drive data on a micro SD card/SD card. If you want to use them after the update, you can copy the data from the micro SD card/SD card to the drive (Page 177).

#### CAUTION

##### Update failure due to improper firmware files

An update failure can be caused by improper firmware files or files missing. When the update fails, the RDY indicator flashes red at 2 Hz and the COM indicator becomes red on. If the firmware files on the micro SD card/SD card are corrupt, the servo drive **cannot** start up after power-on. If the firmware on the micro SD card/SD card is the same with the current firmware of the servo drive, **only** a restart is performed.

- Try to update the firmware again using proper firmware files. If the failure persists, contact your local distributor.

#### Note

##### Update the firmware by restarting the drive.

After inserting the micro SD card/SD card with proper firmware files, you can also update the firmware by restarting the drive.



## 6.5.7 Adjusting AI offsets

### NOTICE

#### Connect to ground

You must firstly connect the AI1 or AI2 to ground and then adjust AI offset.

Refer to section "Analog inputs (Page 117)".

With the BOP function menu "A OFF1" or "A OFF2", AI offset can be adjusted automatically. To use this, function proceed as follows.

- Adjust AI1 offset

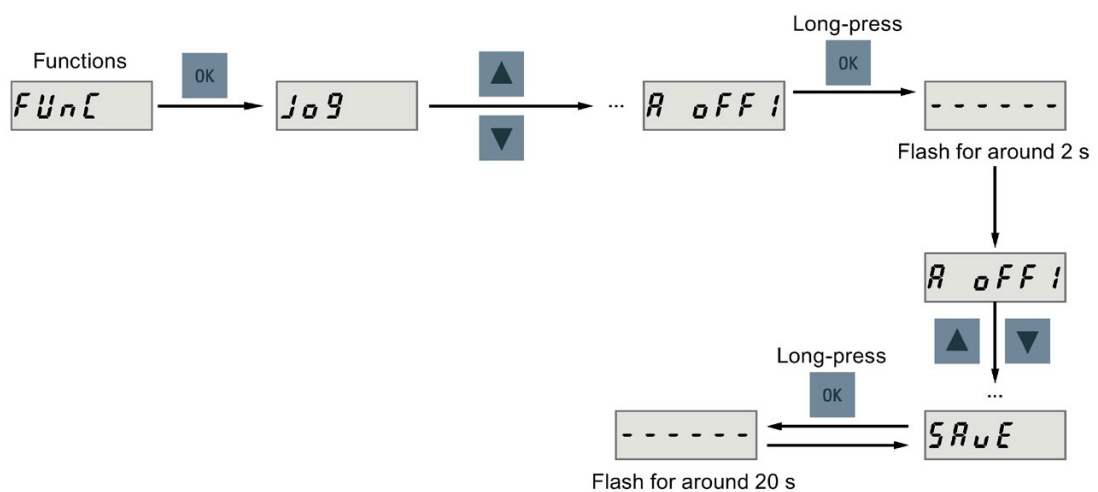

- Adjust AI2 offset

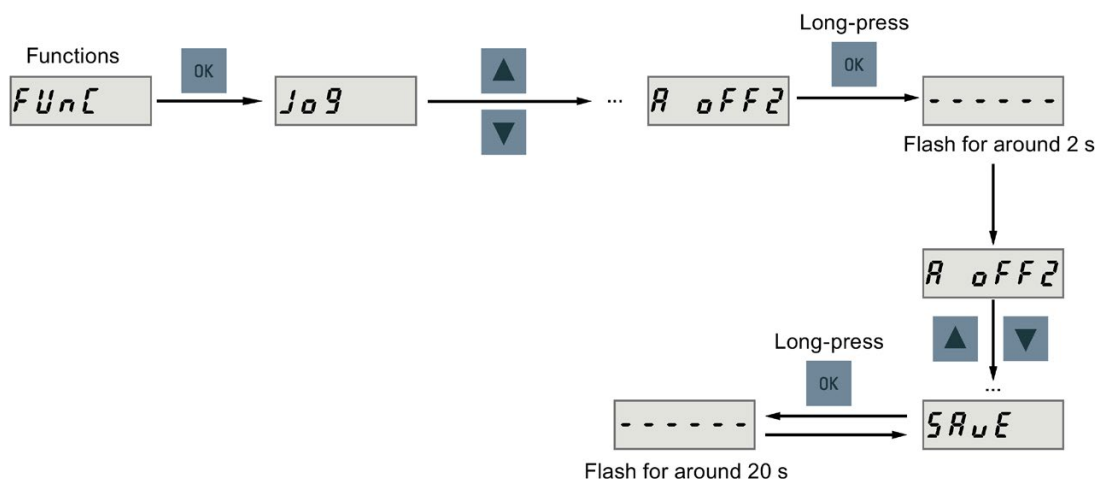

---

**Note**

**Save parameter**

Offset value is set into parameter p29042 (for AI2) or parameter p29061 (for AI1). You **must** perform parameter saving after the automatic adjustment of AI offset.

**Parameter range**

p29042 and p29061 range from -0.5 V to +0.5 V. A value that is out of this range causes an alarm.

Refer to chapter "Parameter list (Page 311)".

---

### 6.5.8 Adjusting an absolute encoder

---

**Note**

**Motor type**

This function is **only** available when you are using a servo motor with the absolute encoder.

**Stop the servo motor**

You must stop the servo motor before adjusting the absolute encoder.

---

With the BOP function menu "**ABS**", you can set the current position of an absolute encoder to the zero position. To do this, proceed as follows.

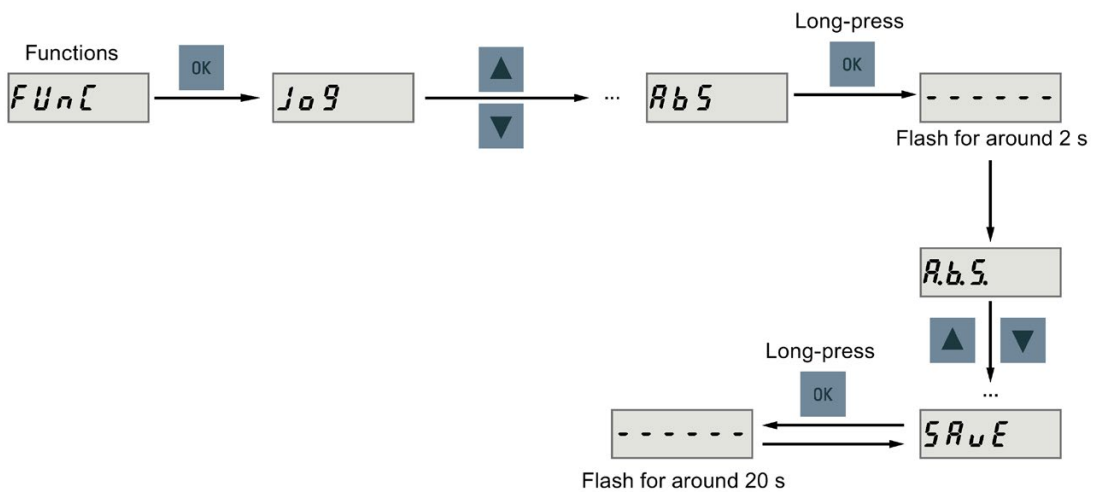

---

**Note**

**Save parameter**

The position value is set in parameter p2525. You **must** save the parameters after setting the zero position.

---

## Control functions

### 7.1 Compound controls

#### Control modes

Nine control modes are available for the SINAMICS V90 servo drive:

Basic control modes	Pulse train input position control mode (PTI) <sup>1)</sup>
	Internal position control mode (IPos)
	Speed control mode (S)
	Torque control mode (T)
Compound control modes	Control change mode: PTI/S
	Control change mode: IPos/S
	Control change mode: PTI/T
	Control change mode: IPos/T
	Control change mode: S/T

<sup>1)</sup> Default control mode

#### Selecting a control mode

You can select a control mode by directly setting parameter p29003.

Parameter	Range	Default	Unit	Description
p29003	0 to 8	0	-	Basic control modes: <ul style="list-style-type: none"> <li>• 0: Pulse train input position control mode</li> <li>• 1: Internal position control mode</li> <li>• 2: Speed control mode</li> <li>• 3: Torque control mode</li> </ul> Compound control modes: <ul style="list-style-type: none"> <li>• 4: Control change mode: PTI/S</li> <li>• 5: Control change mode: IPos/S</li> <li>• 6: Control change mode: PTI/T</li> <li>• 7: Control change mode: IPos/T</li> <li>• 8: Control change mode: S/T</li> </ul>

### Control mode change for a compound control mode

For a compound control mode, you can change between two basic control modes by setting the parameter p29003 and configuring the level sensitive signal C-MODE on DI10.

p29003	C-MODE	
	0 (the first control mode)	1 (the second control mode)
4	PTI	S
5	IPos	S
6	PTI	T
7	IPos	T
8	S	T

Refer to Section "DIs (Page 107)" for detailed information about DIs.

---

#### Note

Note that if p29003 = 5 and the motor has been working in speed control mode for a certain period of time; or p29003 = 7 and the motor has been working in torque control mode for a certain period of time, the fault code F7493 might appear on the drive BOP. This, however, will not cause the motor to stop. The motor remains operative under this circumstance and you can clear the fault code manually.

---

#### Note

Fault F52904 occurs when the control mode is changed via p29003. You must save the parameter and then re-power on the servo drive to apply relevant configurations. For more information about the remedy and acknowledgement of this fault, refer to Section "List of faults and alarms (Page 353)".

---

#### Note

##### Switching conditions

For the switching from PTI or IPos to S or T, you are recommended to perform control mode switching after the INP (in position) signal is at high level.

For the switching from S or T to PTI or IPos, you can perform control mode switching only after the motor speed is lower than 30 rpm.

---

## 7.2 General functions

### 7.2.1 Travel to fixed stop

The function can be used to move the motor to a fixed stop at a specified torque without a fault being signaled. The specified torque is built up and remains applied after the motor reaches the fixed stop.

The desired torque derating is brought about by scaling the upper torque limit and the lower torque limit.

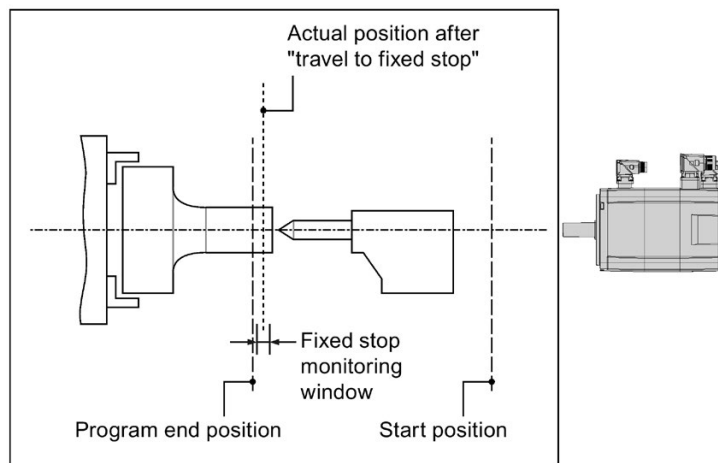

#### Function behavior in PTI control mode

You can configure the function of travelling to fixed stop by setting the following parameter. When the fixed stop is reached, the drive sets the digital output torque limit reached (TLR).

Parameter	Range	Default	Unit	Description
p29045	0 to 1	0	-	<ul style="list-style-type: none"> <li>0: Travel to fixed stop is inactive</li> <li>1: Travel to fixed stop is active.</li> </ul>

Signal type	Signal name	Setting	Description
DO	TLR	0	The generated torque has not reached any torque limit.
		1	The generated torque has nearly (internal hysteresis) reached the value of the positive torque limit, negative torque limit or analog torque limit.

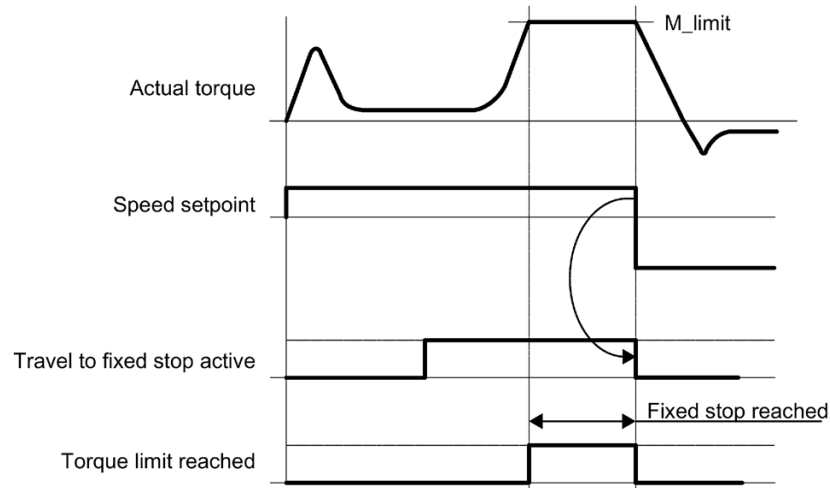

### Example

This example shows the operating procedures when you use the "Travel to fixed stop" function in PTI control mode.

#### Prerequisites:

Use a 0.4 kW low inertia motor (rated torque = 1.27 Nm)

#### Procedures:

1. Set the p29045 = 1 to enable the "Travel to fixed stop" function.
2. Set the required torque limit. The smaller value of the following two torque limits will be the active one.

#### Example

Internal torque limit TLM1:

- p29050[0] = 300 → Positive torque limit
- p29051[0] = -300 → Negative torque limit

Overall torque limit:

- p1520 = 100 Nm → Positive overall torque limit
- p1521 = -150 Nm → Negative overall torque limit

Actual torque limit = 300% × 1.27 Nm = 3.81 Nm

3. Servo on the motor and it traverses to the fixed stop.

The motor runs at the set speed until it reaches the stop and continues to work against the stop until the torque limit has been reached.

## Function behavior in IPos control mode

When the drive is working in IPos traversing block mode, if a traversing block is processed with the FIXED STOP command (p2621[0...7] = 2), the function starts. You can set a torque limit for the FIXED STOP function. An adjustable monitoring window for travel to fixed stop prevents the drive from traveling beyond the window if the fixed stop should break away.

Parameter	Range	Value	Description
p2621[0...7]	1 to 2	1 (default)	POSITIONING
		2	FIXED STOP

From the start position onwards, the target position is approached with the parameterized speed (p2618). The fixed stop (the workpiece) must be between the start position and the braking point of the axis; that is, the target position is placed inside the workpiece. The preset torque limit is effective from the start, i.e. travel to fixed stop also occurs with a reduced torque. The preset acceleration and deceleration overrides and the current speed override are also effective. When the fixed stop is reached, the drive sets the digital output torque limit reached (TLR).

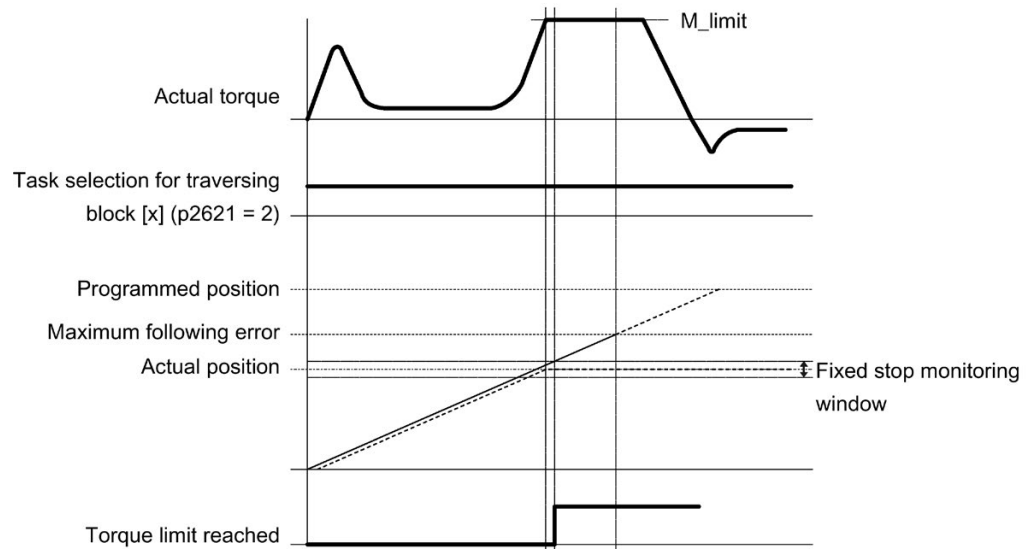

### Note

F7452 is disabled when the function of travelling to fixed stop is activated.

### Fixed stop is reached

As soon as the axis comes into contact with the mechanical fixed stop, the closed-loop control in the drive raises the torque so that the axis can move on. The torque increases up to the value specified in the task and then remains constant. If the actual position following error exceeds the value set in parameter p2634 (fixed stop: maximum following error), fixed stop is reached.

Once the "Fixed stop reached" status has been detected, the traversing task "Travel to fixed stop" is ended.

As long as the drive remains in fixed stop, the position setpoint is adjusted to the actual position value (position setpoint = actual position value). Fixed stop monitoring and controller enable are active.

---

**Note**

If the drive is in fixed stop, it can be referenced using the control signal "Set reference point".

---

If the axis leaves the position that it had at detection of the fixed stop by more than the selected monitoring window for the fixed stop p2635, the speed setpoint is set to 0, and fault F7484 "Fixed stop outside of the monitoring window" is triggered with the reaction OFF3 (quick stop). The monitoring window can be set using the parameter p2635 ("Fixed stop monitoring window"). It applies to both positive and negative traversing directions and must be selected such that it will only be triggered if the axis breaks away from the fixed stop.

**Fixed stop is not reached**

If the brake application point is reached without the "fixed stop reached" status being detected, then the fault F07485 "Fixed stop is not reached" is output with fault reaction OFF1, the torque limit is canceled and the drive cancels the traversing block.

**Overview of important parameters**

- p2617[0...7] Traversing block position
- p2618[0...7] Traversing block velocity
- p2621[0...7] Internal positioning task
- p2634 Fixed stop maximum following error
- p2635 Fixed stop monitoring window

For more information about the parameters above, see Section "Parameter list (Page 313)".

**Example**

This example shows the operating procedures when you use the "Travel to fixed stop" function in IPos control mode.

**Prerequisites:**

Use a 0.4 kW low inertia motor (rated torque = 1.27 Nm)

**Procedures:**

1. Set the target position of traversing block 0.  
p2617[0] = 10000
2. Configure the traversing task to be "FIXED STOP".  
p2621[0] = 2
3. Set the required torque limit. The smaller value of the internal torque limit TLM and the overall torque limit will be the active one.
4. Set the maximum following error by p2634 and the monitoring window by p2635.



5. Perform referencing.

**Note:**

When the SINAMICS V90 is working in IPos traversing block mode, referencing must be performed before moving the axis.

6. After the drive performs referencing successfully, trigger traversing block 0 by the DI signal P-TRG.
7. Observe the drive status to check whether the fixed stop is reached.

**Fixed stop is reached:**

- If the actual position following error exceeds the value set in parameter p2634, fixed stop is reached.

**Fixed stop is not reached:**

- After the fixed stop is reached, if the axis leaves the fixed stop and exceeds the monitoring window (p2635), the speed setpoint is set to 0, and fault F7484 occurs
- If the brake application point is reached without the "fixed stop reached" status being detected, then the fault F7485 occurs

8. Once the "Fixed stop reached" status has been detected, the traversing task "Travel to fixed stop" is ended.

## 7.2.2 Servo ON

### Servo ON signal (SON)

Signal type	Signal name	Pin assignment	Setting	Description
DI	SON	X8-5 (factory setting)	ON = rising edge	Servo motor circuit is connected (the motor is in "S ON" state). Servo motor is ready to run.
			OFF = falling edge	Servo motor circuit is shut off (the motor is in "S OFF" state). Servo motor is not ready to run.

### Relevant parameter settings

Parameter	Value setting	Description
p29301	1	Signal SON (signal number: 1) is assigned to digital input 1 (DI1).
p29300	bit 0 = 1	Set signal SON at a high level forcibly.

**Note**

Refer to Section "Digital inputs/outputs (DIs/DOs) (Page 106)" for detailed information about DI parameterization.

Refer to Chapter "Parameters (Page 311)" for detailed information about parameters.



**Note**

When you set bit 0 of p29300 to 1, the following apply:

- After the drive is powered on, it will be set to "S ON" state automatically.
- After a fault is acknowledged, the drive will be set to "S ON" state automatically.

**7.2.3 Motor direction of rotation**

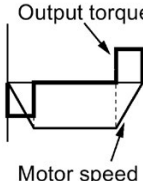
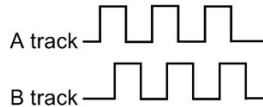
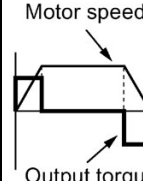
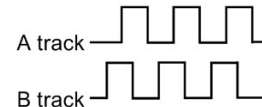
With parameter p29001, you can reverse the direction of rotation of the motor without changing the polarity of pulse train input setpoint and analog input setpoint. The polarity of output signals like pulse train encoder output (PTO) and analog monitoring remains unchanged at a reversal of direction.

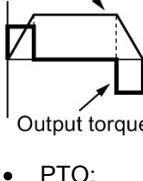
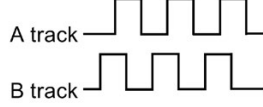
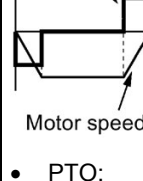
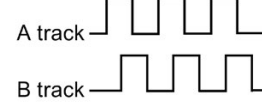
Parameter	Value	Description	Setpoint	
			Positive	Negative
p29001	0	CW is forward direction (factory setting) 	<ul style="list-style-type: none"> <li>• Analog monitoring:   </li> <li>• PTO:   </li> </ul>	<ul style="list-style-type: none"> <li>• Analog monitoring:   </li> <li>• PTO:   </li> </ul>
	1	CCW is forward direction 	<ul style="list-style-type: none"> <li>• Analog monitoring:   </li> <li>• PTO:   </li> </ul>	<ul style="list-style-type: none"> <li>• Analog monitoring:   </li> <li>• PTO:   </li> </ul>

**Note**

After modifying parameter p29001, the reference point will be lost. When the drive is working in IPos control mode, you must perform referencing again.

## 7.2.4 Over-travel

When the servo motor travels over the distance limit, the limit switch is turned on and then the servo motor has a quick stop.

### Travel limit signal (CWL/CCWL)

In S, T, PTI, or IPos control mode, the motor rotates properly after you do as follows:

- When F7492 is triggered after the STOP cam plus is reached in a positive traversing direction, acknowledge the fault using the RESET signal, and then move the axis away from the STOP cam plus in a negative traversing direction to return it to a position within the valid traversing range.
- When F7491 is triggered after the STOP cam minus is reached in a negative traversing direction, acknowledge the fault using the RESET signal, and then move the axis away from the STOP cam minus in a positive traversing direction to return it to a position within the valid traversing range.

 <b>WARNING</b>
<b>Danger to life or malfunctions of the machine due to the motor travelling over the distance limit</b>
In T control mode, the motor travels over the distance limit if you only acknowledge the fault without returning the axis to a position within the valid traversing range.
In S control mode, the motor travels over the distance limit if you only acknowledge the fault without returning the axis to a position within the valid traversing range while signal CWL or CCWL becomes from a low level (logic 0) to a high level (logic 1).
<ul style="list-style-type: none"><li>• Acknowledge the fault, and then return the axis to a position within the valid traversing range to prevent the motor from travelling over the distance limit.</li></ul>

### Note

- Make sure both signals CWL and CCWL are at a high level when the servo drive is powered on.
- In S control mode, the motor cannot rotate with no fault if you only acknowledge the fault without returning the axis to a position within the valid traversing range while signal CWL or CCWL keeps at a low level.
- In PTI or IPos control mode, the motor cannot rotate with F7491/F7492 being triggered again, if you only acknowledge the fault without returning the axis to a position within the valid traversing range.

Signal **CWL** functions as the clockwise travel limit while signal **CCWL** functions as the counter-clockwise travel limit. Both of them are level and edge sensitive signals.

Signal type	Signal name	Pin assignment	Setting	Description
DI	CWL	X8-7 (factory setting)	Falling edge (1→0)	The servo motor has travelled to the clockwise travel limit and has a quick stop after that.
DI	CCWL	X8-8 (factory setting)	Falling edge (1→0)	The servo motor has travelled to the counter-clockwise travel limit and has a quick stop after that.

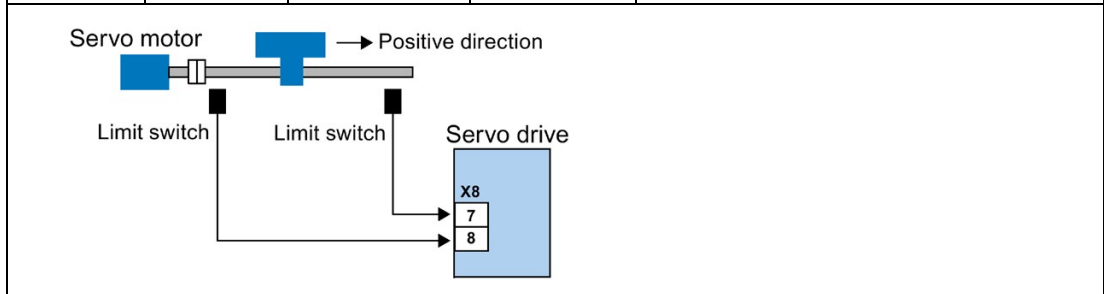

Relevant parameter settings

Parameter	Value setting	Description
p29303	3	Signal <b>CWL</b> (signal number: 3) is assigned to DI3.
p29304	4	Signal <b>CCWL</b> (signal number: 4) is assigned to DI4.
p29300	bit 1 = 1	Set signal <b>CWL</b> at a high level or rising edge forcedly.
	bit 2 = 1	Set signal <b>CCWL</b> at a high level or rising edge forcedly.

Note

DI parameterization

Refer to Section "Digital inputs/outputs (DIs/DOs) (Page 106)" for detailed information about DI parameterization.

Refer to Chapter "Parameters (Page 311)" for detailed information about parameters.

## 7.2.5 Stopping method at servo OFF

You can select a stopping method when the drive is in "S OFF" state. The following stopping methods are available:

- Ramp-down (OFF1)
- Coast-down (OFF2)
- Quick stop (OFF3)

### Ramp-down (OFF1) and coast-down (OFF2)

The ramp-down and coast-down can be configured with the digital input signal SON.

#### SON in PTI, IPos or S mode

Signal type	Signal name	Pin assignment	Setting	Description
DI	SON	X8-5 (factory setting)	Rising edge (0→1)	Power circuit is powered on and the servo drive is ready to run.
			Falling edge (1→0)	Motor ramps down.

#### SON in T mode

Signal type	Signal name	Pin assignment	Setting	Description
DI	SON	X8-5 (factory setting)	Rising edge (0→1)	Power circuit is powered on and the servo drive is ready to run.
			Falling edge (1→0)	Motor coasts down.

### Quick stop (OFF3)

The quick stop can be configured with the digital input signal EMGS.

Signal type	Signal name	Pin assignment	Setting	Description
DI	EMGS	X8-13 (fixed)	1	Servo drive is ready to run.
			0	Quick stop.

For detailed information about the digital input signals SON and EMGS, refer to Section "Digital inputs/outputs (DIs/DOs) (Page 106)".

## 7.3 Pulse train input position control (PTI)

### 7.3.1 Sequence of SON

When the SINAMICS V90 servo drive operates in pulse train input position control mode (PTI), the pulse train setpoint must be send out after the RDY signal is ok.

#### Timing diagram

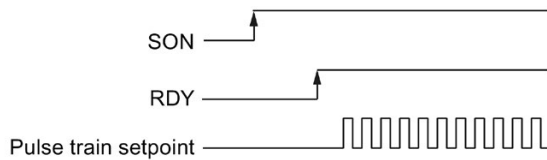

### 7.3.2 Selecting a setpoint pulse train input channel

As mentioned before, the SINAMICS V90 servo drive supports two channels for the setpoint pulse train input:

- 24 V single end pulse train input
- High-speed 5 V differential pulse train input (RS485)

You can select one of these two channels by setting the parameter p29014.

Parameter	Range	Default	Unit	Description
p29014	0 to 1	1	-	<ul style="list-style-type: none"> <li>• 0: High-speed 5 V differential pulse train input (RS485)</li> <li>• 1: 24 V single end pulse train input</li> </ul>

The position pulse train inputs come from either of the following two terminal groups.

Group 1		Group 2	
Signal name	Pin assignment	Signal name	Pin assignment
PTIA_D+	X8-1	PTIA_24P	X8-36
PTIA_D-	X8-2	PTIA_24M	X8-37
PTIB_D+	X8-26	PTIB_24P	X8-38
PTIB_D-	X8-27	PTIB_24M	X8-39

For more information about wiring, see Section "Control/status interface - X8 (Page 103)" and "PTIs (Page 115)".

### 7.3.3 Selecting a setpoint pulse train input form

The SINAMICS V90 servo drive supports two kinds of setpoint pulse train input forms:

- AB track pulse
- Pulse + Direction

For both forms, positive logic and negative logic are supported.

Pulse train input form	Positive logic = 0		Negative logic = 1	
	Forward (CW)	Reverse (CCW)	Forward (CW)	Reverse (CCW)
AB track pulse				
Pulse + Direction				

You can select one of the setpoint pulse train input forms by setting the parameter p29010.

Parameter	Range	Default	Unit	Description
p29010	0 to 3	0	-	<ul style="list-style-type: none"> <li>• 0: Pulse + Direction, positive logic</li> <li>• 1: AB track, positive logic</li> <li>• 2: Pulse + Direction, negative logic</li> <li>• 3: AB track, negative logic</li> </ul>

#### Note

After modifying parameter p29010, you must perform referencing again because the reference point will be lost after p29010 changes.

### 7.3.4 In position (INP)

When the deviation between the position setpoint and the actual position is within the preset in-position range specified in p2544, the signal INP (in position) is output.

#### Parameter settings

Parameter	Value range	Setting value	Unit	Description
p2544	0 to 2147483647	40 (default)	LU	Position window (in-position range)
p29332	1 to 13	3	-	Digital output 3 assignment

#### DO configuration

Signal type	Signal name	Pin assignment	Setting	Description
DO	INP	X8-32 (factory setting)	1	Number of droop pulses is in the preset in-position range (parameter p2544)
			0	Droop pulses are beyond the in-position range

### 7.3.5 Smoothing function

With the smoothing function, the position characteristics curve from the pulse train input setpoint can be transformed into an S-curve profile with a time constant specified in p2533.

#### Parameter setting

Parameter	Range	Default	Unit	Description
p2533	0 to 1000	0	ms	Smooths the parameter in response to a sudden position setpoint

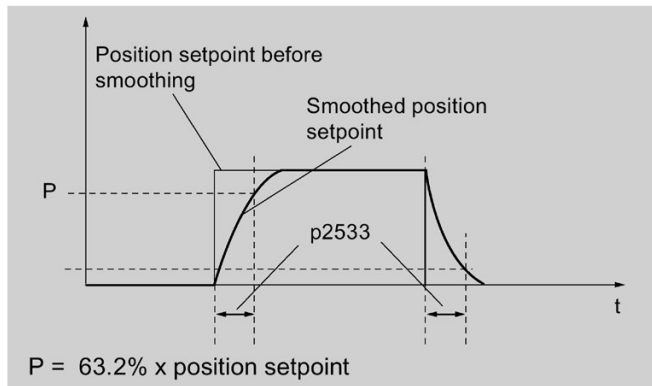



## 7.3.6 Electronic gear ratio

### Encoder specifications

The encoder specifications are shown as follows:

1FL6     -1A  61-0   1  
↓

Type		Resolution	Output pulses per revolution
A	Incremental encoder	2500 ppr	10000
M	Absolute encoder	21-bit single-turn	2097152
L	Absolute encoder	20-bit + 12-bit multi-turn	1048576

### Electronic gear

With the function of electronic gear, you can define the motor revolutions according to the number of setpoint pulses, and sequentially define the distance of mechanical movement. The minimum traveling distance of load shaft according to one setpoint pulse is called a length unit (LU); for example, one pulse results in 1 μm movement.

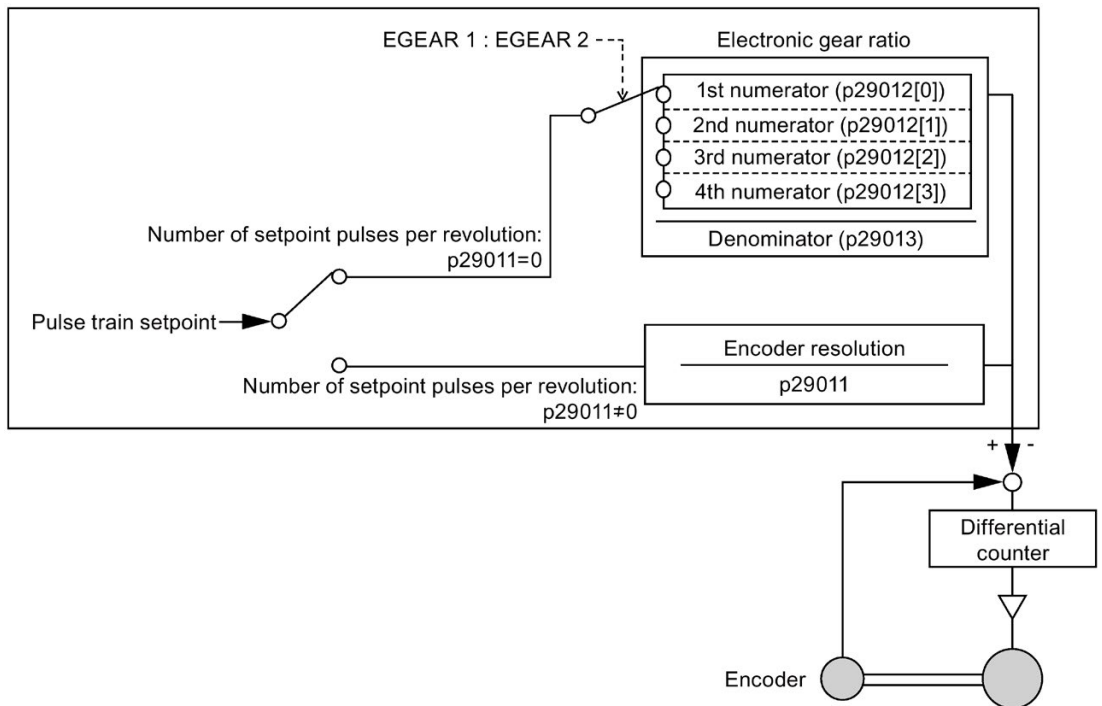

**Benefits of electronic gear (example)**

Move the workpiece for 10 mm 	
<b>Without electronic gear</b>	<b>With electronic gear</b>
Required number of setpoint pulses: $2500 \text{ ppr} \times 4 \times (10 \text{ mm}/6 \text{ mm}) = 16666$	Required number of setpoint pulses: $(10 \text{ mm} \times 1000)/1 \text{ LU} = 10000$

The electronic gear ratio is a multiplier factor to pulse train setpoint. It is realized with a numerator and a denominator. Four numerators (p29012[0], p29012[1], p29012[2], p29012[3]) and one denominator (p29013) are used for the four electronic gear ratios.

Parameter	Range	Default	Unit	Description
p29012[0]	1 to 10000	1	-	The first numerator of electronic gear
p29012[1]	1 to 10000	1	-	The second numerator of electronic gear
p29012[2]	1 to 10000	1	-	The third numerator of electronic gear
p29012[3]	1 to 10000	1	-	The fourth numerator of electronic gear
p29013	1 to 10000	1	-	The denominator of electronic gear

These four electronic gear ratios can be selected with the combination of the digital input signals EGEAR1 and EGEAR2 (refer to Section "DIs (Page 107)").

EGEAR2 : EGEAR1	Electronic gear ratio	Ratio value
0 : 0	Electronic gear ratio 1	p29012[0] : p29013
0 : 1	Electronic gear ratio 2	p29012[1] : p29013
1 : 0	Electronic gear ratio 3	p29012[2] : p29013
1 : 1	Electronic gear ratio 4	p29012[3] : p29013

**Note**

After a gear ratio is switched to another one via digital inputs, you need to wait 10 seconds and then perform **SERVO ON**.

**Note**

The range of electronic gear ratio is from 0.02 to 200.

The electronic gear ratio can be set only at **SERVO OFF** state. After the setting, you need to reference the drive again.

### Calculation formula for the electronic gear ratio

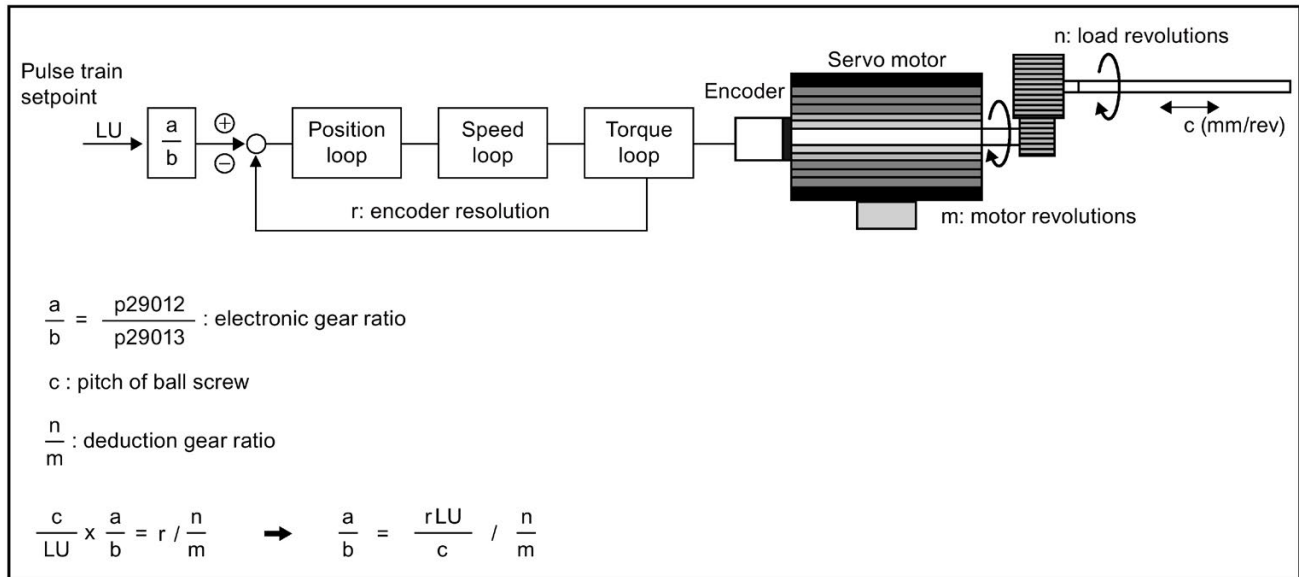

### Examples for calculating the electronic gear ratio

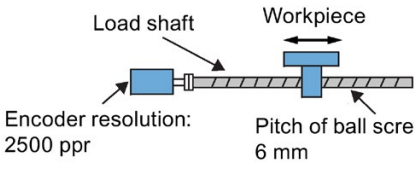
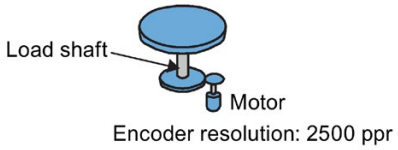
Step	Description	Mechanism	
		Ball screw	Disc table
		LU: 1 $\mu\text{m}$  Encoder resolution: 2500 ppr Pitch of ball screw: 6 mm	LU: 0.01°  Encoder resolution: 2500 ppr
1	Identify mechanism	<ul style="list-style-type: none"> <li>Pitch of ball screw: 6 mm</li> <li>Deduction gear ratio: 1:1</li> </ul>	<ul style="list-style-type: none"> <li>Rotary angle: 360°</li> <li>Deduction gear ratio: 1:3</li> </ul>
2	Identify the encoder resolution	10000	10000
3	Define LU	1 LU = 1 $\mu\text{m}$	1 LU = 0.01°
4	Calculate the travel distance per load shaft revolution	6/0.001 = 6000 LU	360°/0.01° = 36000 LU
5	Calculate the electronic gear ratio	$(1/6000)/(1/1) \times 10000 = 10000/6000$	$(1/36000)/(1/3) \times 10000 = 10000/12000$
6	Set parameters p29012/p29013	10000/6000 = 5/3	10000/12000 = 5/6

### 7.3.7 Inhibiting pulse train input setpoint (P-TRG)

**Note**

**P-TRG in PTI mode**

Note that the function "inhibiting pulse train by P-TRG in PTI mode" as described in this section and the rest of the manual is reserved for future use.

The digital input signal P-TRG is the default connection of DI6 in the position control mode. In the pulse train input position control mode (PTI), P-TRG is level sensitive and can be used to allow or inhibit positioning operation according to pulse train input setpoint:

- 0: positioning according to pulse train input setpoint
- 1: inhibit pulse train input setpoint

**Timing diagram**

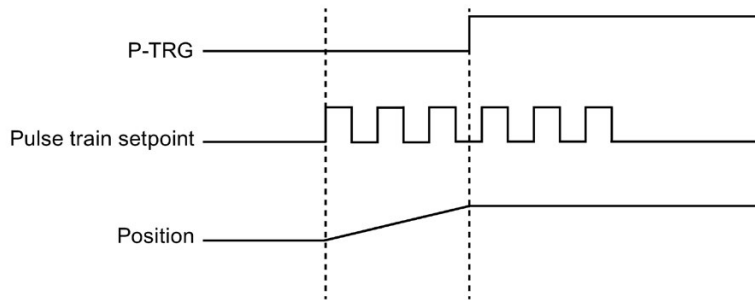

**DI configuration**

The signal P-TRG is the factory setting of DI6.

Signal type	Signal name	Pin assignment	Setting	Description
DI	P-TRG	X8-10 (factory setting)	High level (1)	Inhibit pulse train input setpoint
			Low level (0)	Positioning according to pulse train input setpoint

**Note**

Refer to Section "Digital inputs/outputs (DIs/DOs) (Page 106)" for detailed information about DI parameterization.

- The signal P-TRG is active only when the digital input signal SON is in OFF state.
- When the signal P-TRG is active in the PTI mode or a compound mode with PTI, the alarm A7585 occurs.

### 7.3.8 Speed limit

Four sources in total are available for the speed limit. You can select one of them via a combination of digital input signals SLIM1 and SLIM2.

Digital input		Speed limit
SLIM2	SLIM1	
0	0	Internal speed limit 1
0	1	External speed limit (analog input 1)
1	0	Internal speed limit 2
1	1	Internal speed limit 3

#### Note

##### Control mode

The above four sources are valid in all control modes. You can switch among them when the servo drive is running.

#### Note

Fault F7901 occurs when the actual speed exceeds the positive speed limit + hysteresis speed (p2162) or the negative speed limit - hysteresis speed (p2162). Go to "List of faults and alarms (Page 353)" for information about the acknowledgment of this fault.

#### Note

If the drive is working with external speed limit, the system continues to work automatically after you repower on the 24 VDC power supply which is shut off unexpectedly for the drive. In this case, do not touch the equipment.

Refer to "DIs (Page 107)" for more information about the digital input signals SLIM1 and SLIM2.

### Overall speed limit

Besides the above four channels, an overall speed limit is also available for all control modes.

The overall speed limit can be configured by setting the following parameters.

Parameter	Range	Default	Unit	Description
p1083	0 to 210000	210000	rpm	Overall speed limit (positive)
p1086	-210000 to 0	-210000	rpm	Overall speed limit (negative)

### Internal speed limit

Select an internal speed limit by setting the following parameters.

Parameter	Range	Default	Unit	Description	Digital input	
					SLIM2	SLIM1
p29070[0]	0 to 210000	210000	rpm	Internal speed limit 1 (positive)	0	0
p29070[1]	0 to 210000	210000	rpm	Internal speed limit 2 (positive)	1	0
p29070[2]	0 to 210000	210000	rpm	Internal speed limit 3 (positive)	1	1
p29071[0]	-210000 to 0	-210000	rpm	Internal speed limit 1 (negative)	0	0
p29071[1]	-210000 to 0	-210000	rpm	Internal speed limit 2 (negative)	1	0
p29071[2]	-210000 to 0	-210000	rpm	Internal speed limit 3 (negative)	1	1

#### Note

After the motor is commissioned, p1082, p1083, p1086, p29070 and p29071 set to the maximum speed of the motor automatically.

### External speed limit

Select an external speed limit by setting the following parameters.

Parameter	Value range	Default	Unit	Description
p29060	6 to 210000	3000	rpm	Scaling for analog speed setpoint (maximum speed setpoint corresponding to 10 V)
p29061	-0.5000 to 0.5000	0.0000	V	Offset adjustment for analog input 1 (speed setpoint)

### 7.3.9 Torque limit

Four sources in total are available for the torque limit. You can select one of them via a combination of digital input signals TLIM1 and TLIM2.

Digital input		Torque limit
TLIM2	TLIM1	
0	0	Internal torque limit 1
0	1	External torque limit (analog input 2)
1	0	Internal torque limit 2
1	1	Internal torque limit 3

When the torque setpoint reaches torque limit, the torque is limited to the value selected by TLIM1/TLIM2.

---

#### Note

##### Control mode

The above four sources are valid in the PTI mode, the IPos mode and the S mode. You can switch among them when the servo drive is running.

---

#### Note

When the motor torque exceeds the torque limit, fault F52911/F52912 appears. The fault indicates the motor torque exceeds the torque limitation of the selected group which is determined by TLM1 and TLM2.

---

Refer to "DIs (Page 107)" for more information about the digital input signals TLIM1 and TLIM2.

### Overall torque limit

Besides the above four sources, an overall torque limit is also available for **all** control modes. The overall torque limit takes effect when an quick stop (OFF3) happens. In this case, the servo drive brakes with a maximum torque.

Parameter	Range	Default	Unit	Description
p1520	-1000000.00 to 20000000.00	0	Nm	Overall torque limit (positive)
p1521	-20000000.00 to 1000000.00	0	Nm	Overall torque limit (negative)

### Internal torque limit

Select an internal torque limit by setting the following parameters.

Parameter	Range	Default	Unit	Description	Digital input	
					TLIM2	TLIM1
p29043	-100 to 100	0	%	Fixed torque setpoint	-	-
p29050[0]	-150 to 300	300	%	Internal torque limit 1 (positive)	0	0
p29050[1]	-150 to 300	300	%	Internal torque limit 2 (positive)	1	0
p29050[2]	-150 to 300	300	%	Internal torque limit 3 (positive)	1	1
p29051[0]	-300 to 150	-300	%	Internal torque limit 1 (negative)	0	0
p29051[1]	-300 to 150	-300	%	Internal torque limit 2 (negative)	1	0
p29051[2]	-300 to 150	-300	%	Internal torque limit 3 (negative)	1	1

The following diagram shows how the internal torque limit functions.

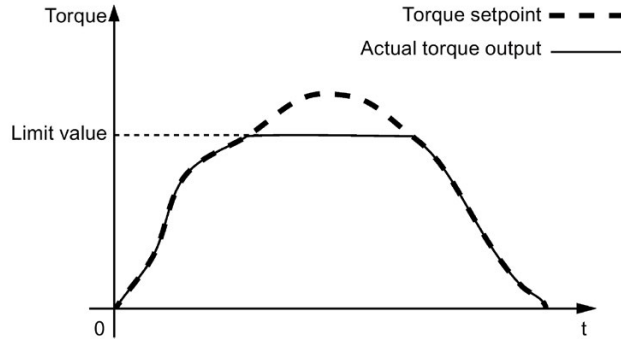

**External torque limit**

Parameter	Range	Default	Unit	Description	Digital input	
					TLIM2	TLIM1
p29041[1]	0 to 300	300	%	Analog torque limit scaling (value corresponding to 10 V)	0	1

p29041[1] is the scaling of analog input 2.

For example, if p29041[1] is 100%, the relationship between torque limit value and analog input is shown as follows:

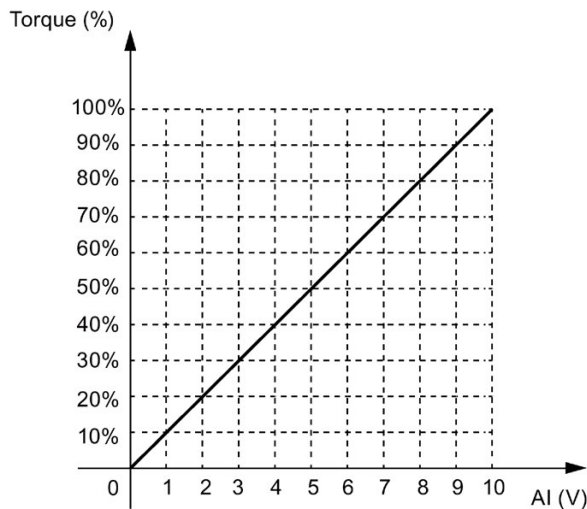

In this case, analog input of 5 V corresponds to 50% of rated torque and 10 V corresponds to 100% of rated torque.

**Torque limit reached (TLR)**

When the generated torque has nearly (internal hysteresis) reached the value of the positive torque limit, negative torque limit or analog torque limit, the signal TLR is output.



### 7.3.10 Clearing droop pulses (CLR)

The droop pulses can be cleared with the parameter p29242 and the digital input signal CLR.

#### Selecting a clear mode by setting p29242

You can select a clear mode by setting the parameter p29242.

Parameter	Range	Default	Unit	Description
p29242	0 to 2	0	-	<ul style="list-style-type: none"> <li>0: do not clear droop pulses</li> <li>1: clear droop pulses with the high level</li> <li>2: clear droop pulses with the rising edge</li> </ul>

#### Clearing droop pulses with DI signal CLR

You can clear the droop pulses with the DI signal CLR after p29242 is set. The signal CLR is the factory setting of pin 11 (DI7) on the control/status interface (X8).

##### p29242 = 0

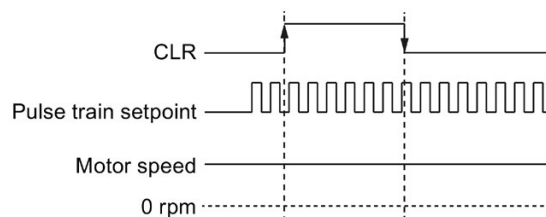

##### p29242 = 1

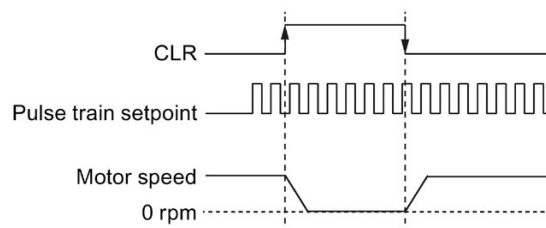

##### p29242 = 2

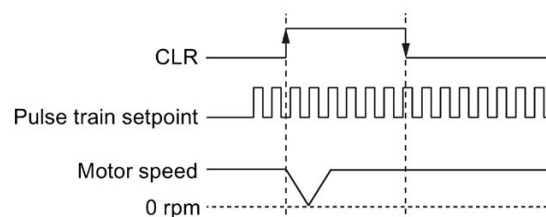

**Note**

When you use the CLR high level to clear the pulses ( $p29242 = 1$ ), the high level need to be kept for more than 8 ms.

When the signal CLR is active in the PTI mode or a compound mode with PTI, the alarm A7585 occurs.

If there are overshoot when you use the CLR function, you need to increase the integral time ( $p29121$ ).

**7.3.11 Referencing (only for absolute encoder)**

If an absolute encoder is used, you must adjust the absolute encoder with the BOP menu function "ABS". For more information about the "ABS" menu function, see Section "Adjusting an absolute encoder (Page 180)".

**7.3.12 PTO function**

**Function**

A pulse train encoder output (PTO) which provides pulse signals can transmit the signals to the controller to realize a closed-loop control system inside the controller, or transmit them to another drive as pulse train setpoint for a synchronous axis.

**Electronic gear**

The electronic gear ratio is a multiplier factor to the PTO to a controller. It is realized with a numerator and a denominator. One numerator ( $p29031$ ) and one denominator ( $p29032$ ) are used for the PTO electronic gear ratio:

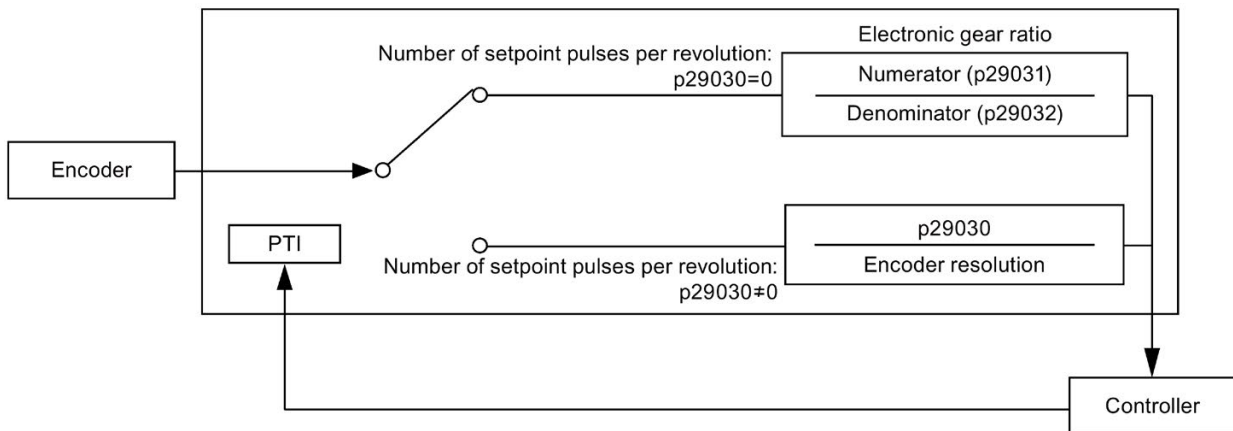

Parameter	Range	Default	Unit	Description
p29031	1 to 2147000000	1	-	Numerator of output pulse
p29032	1 to 2147000000	1	-	Denominator of output pulse

**Note**

When you use the PTO electronic gear function, for the absolute encoder, the electronic gear is based on the resolution of 8192 ppr.

The range of electronic gear ratio is from 0.02 to 200.

The electronic gear ratio can be set at **SERVO OFF** state only.

**Note****PTO direction**

For an application of fully closed-loop position control using PTI and PTO, you can set the PTO direction with parameter p29033.

**Note**

When using the PTO function, the drive will output some pulses before the motor servo on if you executing the following operations.

- Default the drive with the BOP instruction.
- Configure the motor ID on the drive.

**Note**

When you use the PTO electronic gear ratio function, zero mark will not be generated.

**PTO zero mark**

Make the servo motor rotate for more than one revolution before using PTO's zero mark for referencing.

## 7.4 Internal position control (IPos)

### 7.4.1 Setting mechanical system

By parameterizing the mechanical system, the link between the physical moving part and the length unit (LU) is established.

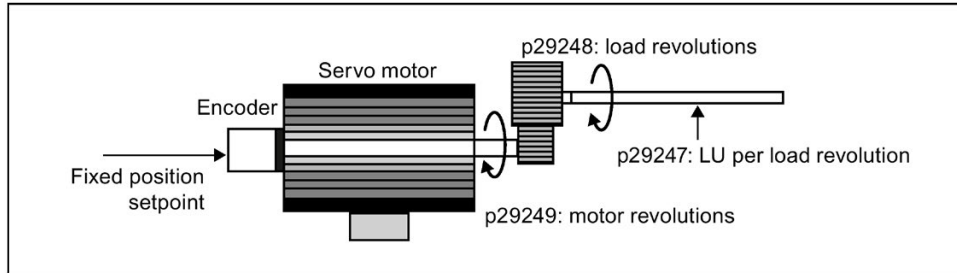

The unit of the fixed position setpoint is the Length Unit (LU). All subsequent position setpoint, related speed value, and acceleration value will maintain the LU as the unit in internal position control mode.

Taking a ball screw system for example, if the system has a pitch of 10 mm/revolution (10000  $\mu\text{m}$ /revolution) and the resolution of the length unit is 1  $\mu\text{m}$  (1 LU = 1  $\mu\text{m}$ ), one load revolution corresponds to 10000 LU (p29247 = 10000).

#### Note

If the value of p29247 increases by N times, the values of p2542, p2544 and p2546 should increase by N times accordingly. Otherwise, the fault F7450 or F7452 occurs.

### Relevant parameters

Parameter	Range	Default	Unit	Description
p29247	1 to 2147483647	10000	-	LU per load revolution
p29248	1 to 1048576	1	-	Load revolutions
p29249	1 to 1048576	1	-	Motor revolutions

### Examples for configuring mechanical system

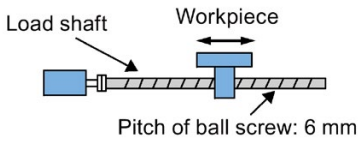
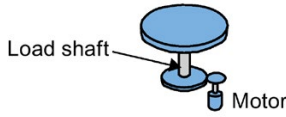
Step	Description	Mechanical system		
		Ball screw	Disc table	
		 <p>Pitch of ball screw: 6 mm</p>	 <p>Motor</p>	
1	Identify the mechanical system	<ul style="list-style-type: none"> <li>Pitch of ball screw: 6 mm</li> <li>Reduction gear ratio: 1:1</li> </ul>	<ul style="list-style-type: none"> <li>Rotary angle: 360°</li> <li>Reduction gear ratio: 3:1</li> </ul>	
2	Define LU	1 LU = 1 μm	1 LU = 0.01°	
3	Calculate the LU per load shaft revolution	6/0.001 = 6000 LU	360/0.01 = 36000 LU	
4	Set parameters	p29247	6000	36000
		p29248	1	1
		p29249	1	3

### 7.4.2 Setting fixed position setpoint

Eight position setpoints in total are available. Each position setpoint comes from one group of position data.

Fixed position setpoint	Corresponding parameters	
	Parameter	Description
Fixed position setpoint 1	p2617[0]	Fixed position setpoint 1 (P_pos1)
	p2618[0]	Speed of fixed position setpoint 1 (P_pos_spd1)
	p2572	IPos maximum acceleration
	p2573	IPos maximum deceleration
Fixed position setpoint 2	p2617[1]	Fixed position setpoint 2 (P_pos2)
	p2618[1]	Speed of fixed position setpoint 2 (P_pos_spd2)
	p2572	IPos maximum acceleration
	p2573	IPos maximum deceleration
Fixed position setpoint 3	p2617[2]	Fixed position setpoint 3 (P_pos3)
	p2618[2]	Speed of fixed position setpoint 3 (P_pos_spd3)
	p2572	IPos maximum acceleration
	p2573	IPos maximum deceleration
Fixed position setpoint 4	p2617[3]	Fixed position setpoint 4 (P_pos4)
	p2618[3]	Speed of fixed position setpoint 4 (P_pos_spd4)
	p2572	IPos maximum acceleration
	p2573	IPos maximum deceleration

Fixed position setpoint	Corresponding parameters	
	Parameter	Description
Fixed position setpoint 5	p2617[4]	Fixed position setpoint 5 (P_pos5)
	p2618[4]	Speed of fixed position setpoint 5 (P_pos_spd5)
	p2572	IPos maximum acceleration
	p2573	IPos maximum deceleration
Fixed position setpoint 6	p2617[5]	Fixed position setpoint 6 (P_pos6)
	p2618[5]	Speed of fixed position setpoint 6 (P_pos_spd6)
	p2572	IPos maximum acceleration
	p2573	IPos maximum deceleration
Fixed position setpoint 7	p2617[6]	Fixed position setpoint 7 (P_pos7)
	p2618[6]	Speed of fixed position setpoint 7 (P_pos_spd7)
	p2572	IPos maximum acceleration
	p2573	IPos maximum deceleration
Fixed position setpoint 8	p2617[7]	Fixed position setpoint 8 (P_pos8)
	p2618[7]	Speed of fixed position setpoint 8 (P_pos_spd8)
	p2572	IPos maximum acceleration
	p2573	IPos maximum deceleration

### Parameter settings

Parameter	Range	Default	Unit	Description
p2617[0]...[7]	- 2147482648 to 2147482647	0	LU	Fixed position setpoint 1 to 8
p2618[0]...[7]	1 to 40000000	600	1000 LU/min	Speed of fixed position setpoint 1 to 8
p2572	1 to 2000000	Motor de- pendent	1000 LU/s <sup>2</sup>	IPos maximum acceleration
p2573	1 to 2000000	Motor de- pendent	1000 LU/s <sup>2</sup>	IPos maximum deceleration

#### Note

When the motor is working in the IPos control mode, you need to check that whether the values of the parameters p2542, p2544, p2546, p2573, and p2574 are your desired values. The values are set automatically by the drive based on the encoder resolution.

### 7.4.3 Selecting a positioning mode - absolute/incremental

In the internal position control mode, you can select between absolute positioning mode and incremental positioning mode with the parameter p29241.

Parameter	Range	Default	Unit	Description
p29241	0 to 3	0	-	Absolute or incremental positioning mode: <ul style="list-style-type: none"> <li>• 0: incremental</li> <li>• 1: absolute</li> <li>• 2: absolute, positive (only for a rotary axis with modulo correction)</li> <li>• 3: absolute, negative (only for a rotary axis with modulo correction)</li> </ul>

#### NOTICE

##### Pre-conditions for using the absolute mode

The absolute mode can be used only after:

- the axis has been referenced for incremental measuring system. Refer to Section "Referencing (Page 211)" for detailed information about referencing.
- the axis has been adjusted for absolute measuring system. Refer to Section "Adjusting an absolute encoder (Page 180)" for reference.

#### Example

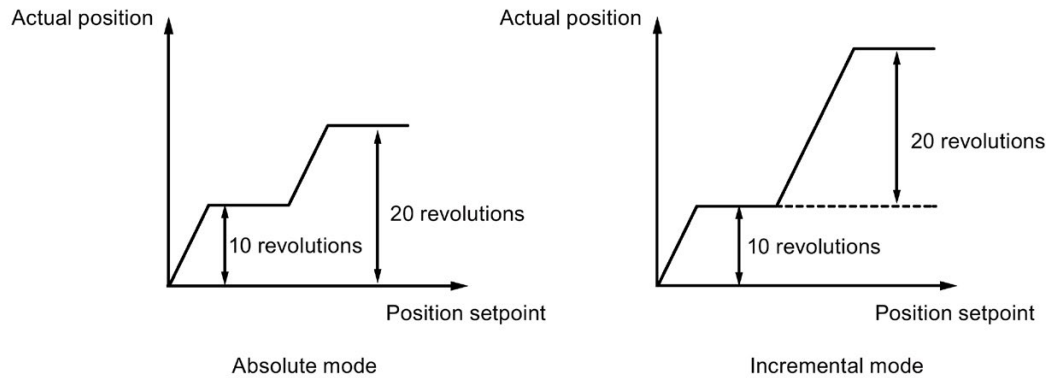

### 7.4.4 Configuring the linear/modular axis

You can choose to use a linear axis or a modular axis depending on your actual application. The linear axis has a restricted traversing range, which is the factory setting of the SINAMICS V90 servo drive.

The modular axis has an unrestricted traversing range. The value range of the position repeats itself after a value is specified in p29245. You can use the modular axis by setting the following parameters additionally.

Parameter	Range	Default	Unit	Description
p29245	0 to 1	0	-	<ul style="list-style-type: none"> <li>0: linear axis</li> <li>1: modular axis</li> </ul>
p29246	1 to 2147482647	360000	LU	Modular range

#### Note

After modifying parameter p29245, you must perform the referencing operation again.

### 7.4.5 Backlash compensation

Generally, backlash occurs when the mechanical force is transferred between a machine part and its drive:

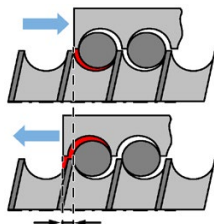

Backlash: p2583

If the mechanical system was to be adjusted/designed so that there was absolutely no backlash, this would result in high wear. Thus, backlash can occur between the machine component and the encoder. For axes with indirect position sensing, mechanical backlash results in a false traversing distance because the axis, at direction reversal, travels either too far or not far enough corresponding to the absolute value of the backlash.

#### Note

##### Pre-conditions for backlash compensation

The backlash compensation is active after

- the axis has been referenced for incremental measuring system. Refer to Section "Referencing (Page 211)" for detailed information about referencing.
- the axis has been adjusted for absolute measuring system. Refer to Section "Adjusting an absolute encoder (Page 180)" for reference.



In order to compensate the backlash, the determined backlash must be specified in p2583 with correct polarity. At each direction of rotation reversal, the axis actual value is corrected dependent on the actual traversing direction.

If the axis has been referenced or adjusted, the setting of parameter p2604 (reference point approach, starting direction) is used to activate the compensation value.

p2604	Traversing direction	Activate compensation value
0	Negative	Immediately
1	Positive	Immediately

## Parameter settings

Parameter	Range	Default	Unit	Description
p2583	-200000 to 200000	0	LU	Backlash compensation
p2604	0 to 1	0	-	Set signal source for start direction of searching cam: <ul style="list-style-type: none"> <li>0: start in positive direction</li> <li>1: start in negative direction</li> </ul>

## 7.4.6 Referencing

### Referencing modes

If the servo motor has an incremental encoder, totally five referencing modes are available:

- Setting reference point with the digital input signal REF
- External reference cam (signal REF) and encoder zero mark
- Encoder zero mark only
- External reference cam (signal CWL) and encoder zero mark
- External reference cam (signal CCWL) and encoder zero mark

If the servo motor has an absolute encoder, the five referencing modes are available. You can also adjust the absolute encoder (by setting current position as the zero position) with the BOP function "ABS". Refer to Section "Adjusting an absolute encoder (Page 180)" for details.

You can select one of these referencing modes by setting the parameter p29240.

Parameter	Range	Default	Unit	Description
p29240	0 to 4	1	-	<ul style="list-style-type: none"> <li>0: Setting reference point with the digital input signal REF</li> <li>1: External reference cam (signal REF) and encoder zero mark</li> <li>2: Encoder zero mark only</li> <li>3: External reference cam (signal CCWL) and encoder zero mark</li> <li>4: External reference cam (signal CWL) and encoder zero mark</li> </ul>

**Note**

**Referencing mode for absolute encoder**

If an absolute encoder is connected, the five referencing modes are available. You can select the different referencing modes with parameter p29240. When p29240 = 1 to 4, the referencing process can only be implemented before you use the "ABS" function. Once the "ABS" function is implemented, the four referencing modes are not available any more.

**Note**

p29240 can be modified only when the drive is in IPos mode.

**Setting reference point with the digital input signal REF (p29240=0)**

**Note**

**Preconditions for this referencing mode**

- The servo motor must be in "S ON" state and keep standstill.
- The signal REF must be OFF under the following conditions:
  - before power-on
  - when switching from another referencing mode to this referencing mode
  - when switching from another control mode to internal position control mode

The current position is set to zero at a rising edge of the signal REF and the servo drive is referenced:

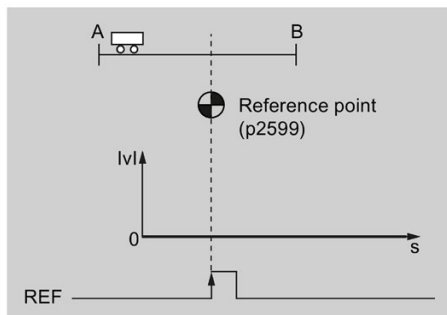

**CAUTION**

The referencing point may not be fixed during referencing.

The servo motor must be in "S ON" state so that the referencing point is fixed during referencing.

**External reference cam (signal REF) and encoder zero mark (p29240=1)**

The referencing is triggered by signal SREF. After that, the servo motor accelerates to the speed specified in p2605 to find the reference cam. The direction (CW or CCW) for searching the reference cam is defined by p2604. When the reference cam is reached (signal REF: 0→1), the servo motor decelerates to standstill. After that, the servo motor accelerates again to the speed specified in p2608 and the running direction is opposite to the direction defined by p2604. Then the signal REF should be switched off (1→0). When the servo motor reaches the first zero mark, it starts to travel towards the reference point defined in p2600 with the speed specified in p2611. When the servo motor reaches the reference point (p2599), the signal REFOK is output. Switch off the signal SREF (1→0) and the referencing finishes successfully.

The whole process is shown in the diagram below:

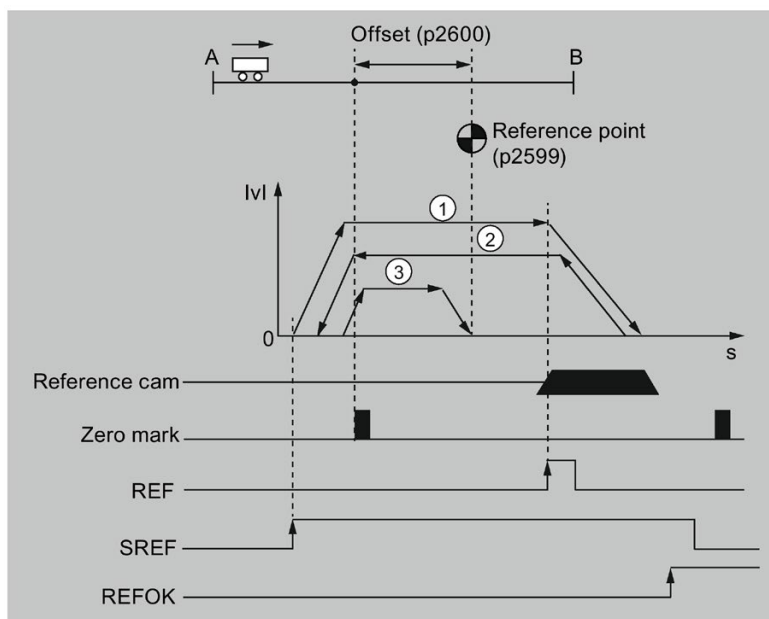

- ① Speed for searching the cam (p2605)
- ↓
- ② Speed for searching zero mark (p2608)
- ↓
- ③ Speed for searching reference point (p2611)

Follow the steps below to perform referencing with this mode:

1. Set relevant parameters.

Parameter	Range	Default	Unit	Description
p2599	-2147482648 to 2147482647	0	LU	Sets the position value for the reference point coordinate.
p2600	-2147482648 to 2147482647	0	LU	Reference point offset
p2604	0 to 1	0	-	Sets signal source for start direction of searching: <ul style="list-style-type: none"> <li>• 0: start in positive direction</li> <li>• 1: start in negative direction</li> </ul>
p2605	1 to 40000000	5000	1000 LU/min	Speed for searching the cam
p2606	0 to 2147482647	2147482647	LU	Maximum distance for searching the cam
p2608	1 to 40000000	300	1000 LU/min	Speed for searching zero mark
p2609	0 to 2147482647	20000	LU	Maximum distance for searching the zero mark
p2611	1 to 40000000	300	1000 LU/min	Speed for searching reference point

2. Configure signals SREF and REF.

Refer to Chapter "Digital inputs/outputs (DIs/DOs) (Page 106)" for reference.

3. Trigger SREF to a rising edge to start referencing.

---

#### Note

During the referencing, if SREF is OFF, the referencing stops.

---

4. If the servo motor reaches the reference point, the signal REFOK (if configured) is output.
5. Switch off the signal SREF, and the referencing finishes successfully.

### Encoder zero mark only (p29240=2)

In this mode, there is no cam available. The referencing is triggered by signal SREF. After that, the servo motor accelerates to the speed specified in p2608 and the direction (CW or CCW) is defined by p2604. When the servo motor reaches the first zero mark, it starts to travel towards the reference point defined in p2600 with the speed specified by p2611. When the servo motor reaches the reference point (p2599), the signal REFOK is output. Switch off the signal SREF (1→0) and the referencing finishes successfully.

The whole process is shown in the diagram below:

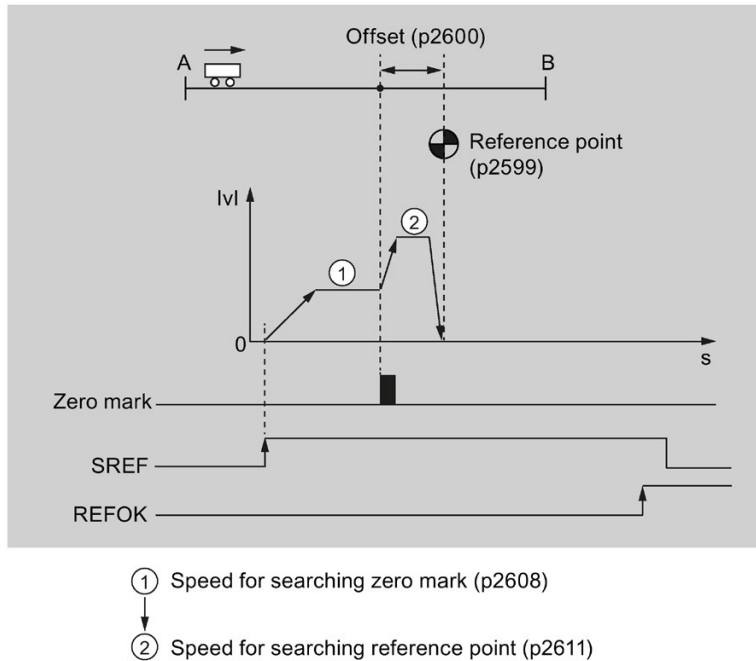

Follow the steps below to perform referencing with this mode:

1. Set relevant parameters.

Parameter	Range	Default	Unit	Description
p2599	-2147482648 to 2147482647	0	LU	Sets the position value for the reference point coordinate.
p2600	-2147482648 to 2147482647	0	LU	Reference point offset
p2604	0 to 1	0	-	Sets signal source for start direction of searching: <ul style="list-style-type: none"> <li>0: start in positive direction</li> <li>1: start in negative direction</li> </ul>
p2608	1 to 40000000	300	1000 LU/min	Speed for searching zero mark
p2609	0 to 2147482647	20000	LU	Maximum distance for searching the zero mark
p2611	1 to 40000000	300	1000 LU/min	Speed for searching reference point

2. Configure the signal SREF.

3. Trigger SREF to a rising edge to start referencing.

**Note**

During the referencing, if SREF is OFF, the referencing stops.

4. If the servo motor reaches the reference point, the signal REFOK (if configured) is output.
5. Switch off the signal SREF, and the referencing finishes successfully.

**External reference cam (signal CCWL) and encoder zero mark (p29240=3)**

The referencing is triggered by signal SREF. After that, the servo motor accelerates to the speed specified in p2605 to find the reference cam. The direction (CCW) for searching the reference cam is defined by p2604. When the signal CCWL is detected (1→0), the servo motor decelerates to standstill with maximum deceleration. After that, the servo motor accelerates again to the speed specified in p2608 and the running direction (CW) is opposite to the direction defined by p2604. The signal CCWL switches to high level (0→1). When the servo motor finds the first zero mark, it starts to travel towards the reference point defined in p2600 with the speed specified in p2611. When the servo motor reaches the reference point (p2599), the signal REFOK is output. Switch off the signal SREF (1→0) and the referencing finishes successfully.

The whole process is shown in the diagram below:

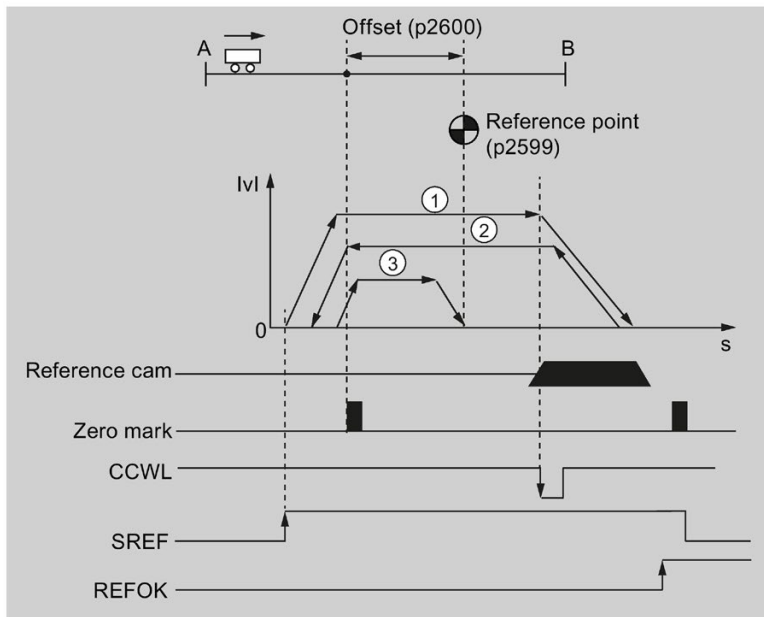

- ① Speed for searching the cam (p2605)
- ② Speed for searching zero mark (p2608)
- ③ Speed for searching reference point (p2611)

**Note**

- During the referencing process, the signals CWL and CCWL are unavailable. Once the process is complete, the signals will act as limits signal again.
- For the safety purpose, the maximum distance for searching the cam (p2606) and the maximum distance for searching the zero mark (p2609) **must** be set.

Follow the steps below to perform referencing with this mode:

1. Set relevant parameters.

Parameter	Range	Default	Unit	Description
p2599	-2147482648 to 2147482647	0	LU	Sets the position value for the reference point coordinate.
p2600	-2147482648 to 2147482647	0	LU	Reference point offset
p2604 <sup>1)</sup>	0 to 1	0	-	Sets signal source for start direction of searching: <ul style="list-style-type: none"> <li>• 0: start in positive direction (CW)</li> <li>• 1: start in negative direction (CCW)</li> </ul>
p2605	1 to 40000000	5000	1000 LU/min	Speed for searching the cam
p2606	0 to 2147482647	2147482647	LU	Maximum distance for searching the cam
p2608	1 to 40000000	300	1000 LU/min	Speed for searching zero mark
p2609	0 to 2147482647	20000	LU	Maximum distance for searching the zero mark
p2611	1 to 40000000	300	1000 LU/min	Speed for searching reference point

<sup>1)</sup> When p29240= 3, the direction for searching the reference cam must be CCW, that is p2604=1.

2. Configure the signal SREF and CCWL.
3. Trigger SREF to a rising edge to start referencing.

**Note**

During the referencing, if SREF is OFF, the referencing stops.

4. If the servo motor reaches the reference point, the signal REFOK (if configured) is output.
5. Switch off the signal SREF, and the referencing finishes successfully.

**External reference cam (signal CWL) and encoder zero mark (p29240=4)**

The referencing is triggered by signal SREF. After that, the servo motor accelerates to the speed specified in p2605 to find the reference cam. The direction (CW) for searching the reference cam is defined by p2604. When the signal CWL is detected (1→0), the servo motor decelerates to standstill with maximum deceleration. After that, the servo motor accelerates again to the speed specified in p2608 and the running direction (CCW) is opposite to the direction defined by p2604. The signal CWL switches to high level (0→1). When the servo motor finds the first zero mark, it starts to travel towards the reference point defined in p2600 with the speed specified in p2611. When the servo motor reaches the reference point (p2599), the signal REFOK is output. Switch off the signal SREF (1→0) and the referencing finishes successfully.

The whole process is shown in the diagram below:

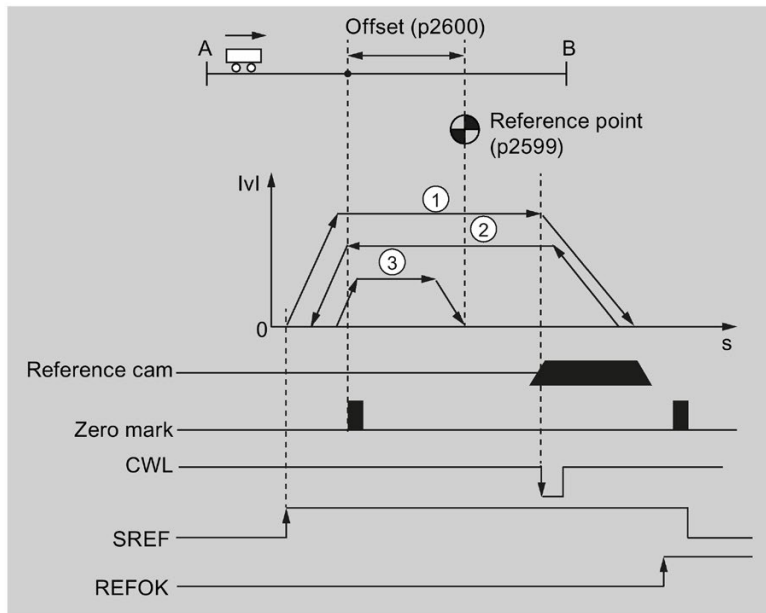

- ① Speed for searching the cam (p2605)
- ↓
- ② Speed for searching zero mark (p2608)
- ↓
- ③ Speed for searching reference point (p2611)

**Note**

- During the referencing process, the signals CWL and CCWL are unavailable. Once the process is complete, the signals will act as limits signal again.
- For the safety purpose, the maximum distance for searching the cam (p2606) and the maximum distance for searching the zero mark (p2609) **must** be set.



Follow the steps below to perform referencing with this mode:

1. Set relevant parameters.

Parameter	Range	Default	Unit	Description
p2599	-2147482648 to 2147482647	0	LU	Sets the position value for the reference point coordinate.
p2600	-2147482648 to 2147482647	0	LU	Reference point offset
p2604 <sup>1)</sup>	0 to 1	0	-	Sets signal source for start direction of searching: <ul style="list-style-type: none"> <li>• 0: start in positive direction</li> <li>• 1: start in negative direction</li> </ul>
p2605	1 to 40000000	5000	1000 LU/min	Speed for searching the cam
p2606	0 to 2147482647	2147482647	LU	Maximum distance for searching the cam
p2608	1 to 40000000	300	1000 LU/min	Speed for searching zero mark
p2609	0 to 2147482647	20000	LU	Maximum distance for searching the zero mark
p2611	1 to 40000000	300	1000 LU/min	Speed for searching reference point

<sup>1)</sup> When p29240= 4, the direction for searching the reference cam must be CW, that is p2604=0.

2. Configure the signal SREF and CWL.
3. Trigger SREF to a rising edge to start referencing.

---

**Note**

During the referencing, if SREF is OFF, the referencing stops.

---

4. If the servo motor reaches the reference point, the signal REFOK (if configured) is output.
5. Switch off the signal SREF, and the referencing finishes successfully.

### 7.4.7 Software position limit

The following two software position limits are available in the internal position control mode:

- Positive position limit
- Negative position limit

The function of software position limit only becomes active after going to reference. When the actual position reaches one of the above-mentioned software position limits, motor speed decelerates to 0.

#### Parameter settings

Parameter	Range	Default	Unit	Description
p2580	-2147482648 to 2147482647	-2147482648	LU	Negative software position limit switch
p2581	-2147482648 to 2147482647	2147482648	LU	Positive software position limit switch
p2582	0 to 1	0	-	Activation of software limit switch: <ul style="list-style-type: none"> <li>• 0: deactivate</li> <li>• 1: activate</li> </ul>

### 7.4.8 Speed limit

Refer to "Speed limit (Page 199)" for details.

### 7.4.9 Torque limit

Refer to "Torque limit (Page 200)" for details.

### 7.4.10 Selecting a fixed position setpoint and starting positioning

In the IPos mode, two methods are available to select a fixed position setpoint and then start motor running according to selected fixed position setpoint:

- select a fixed position setpoint with the co-settings of signals POS1, POS2 and POS3 and then use the trigger signal P-TRG to start positioning
- use the rising edge of the signal STEPF, STEPB or STEPH

Refer to Chapter "Digital inputs/outputs (DIs/DOs) (Page 106)" for detailed information about the signals POS1, POS2, POS3, P-TRG, STEPF, STEPB, STEPH.

### Selecting the target position with the signals POS1, POS2 and POS3, and starting the positioning with the trigger signal P-TRG

Select one of the eight fixed position setpoints with the co-settings of signals POS1, POS2 and POS3:

Fixed position setpoint	Signal		
	POS3	POS2	POS1
Fixed position setpoint 1	0	0	0
Fixed position setpoint 2	0	0	1
Fixed position setpoint 3	0	1	0
Fixed position setpoint 4	0	1	1
Fixed position setpoint 5	1	0	0
Fixed position setpoint 6	1	0	1
Fixed position setpoint 7	1	1	0
Fixed position setpoint 8	1	1	1

In the fixed position control mode, the signals POS1 and POS2 are default assignments of DI7 and DI8 while the signal POS3 is not assigned:

Signal type	Signal name	Pin assignment	Description
DI	POS1	X8-11	Select a fixed position setpoint.
DI	POS2	X8-12	
DI	POS3	To be assigned	

#### Note

##### Configuration of POS3

If the POS3 is not assigned to any DI, its status is assumed to be 0, which means only the following fixed position setpoints can be used:

- Fixed position setpoint 1
- Fixed position setpoint 2
- Fixed position setpoint 3
- Fixed position setpoint 4

After selecting a fixed position setpoint, the servo motor can start positioning at a rising edge of the signal P-TRG.

The digital input signal P-TRG is the default assignment of DI6 in the internal position control mode:

Signal type	Signal name	Pin assignment	Setting	Description
DI	P-TRG	X8-10 (factory setting)	0→1	Starts positioning according to selected fixed position setpoint

The timing diagram for starting positioning with the trigger signal P-TRG is shown as follows:

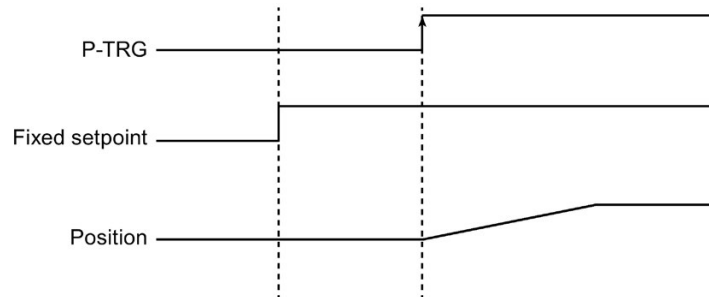

### Selecting the target position and starting the positioning with the rising edge of the signal STEPF, STEPB or STEPH

If the signal STEPF is enabled, the servo motor, at a rising edge of STEPF, traverses to next fixed position setpoint. For example, if the servo motor currently locates at the fixed position setpoint 3, the servo motor traverses to the fixed position setpoint 4 at a rising edge of STEPF.

If the signal STEPB is enabled, the servo motor, at a rising edge of STEPB, traverses to previous fixed position setpoint.

If the signal STEPH is enabled, the servo motor, at a rising edge of STEPH, traverses to the fixed position setpoint 1.

---

#### Note

The servo drive can respond to the rising edge of the signal STEPF, STEPB or STEPH **only** when the servo motor is at a standstill.

If the servo motor is at fixed position 8, a rising edge of STEPF is not responded.

If motor is at fixed position 1, a rising edge of STEPH is responded, but a rising edge of STEPB is not responded.

During positioning, if the motor stops unexpectedly, the drive assumes that the target position has been reached; for example, if the motor stops between POS2 and POS3 because of a fault after the signal STEPB (traversing to POS2) is given, the drive assumes that POS2 has been reached.

---

### 7.4.11 Position tracking

The position tracking function can be used to realize the following features:

- Setting up a virtual multi-turn for a single-turn absolute encoder
- Extending the position area
- Enabling the load position to be reproduced when using gearboxes

If the position tracking function is enabled, the actual position value can be saved in a power-off retentive memory when you power off the drive. When you power on the drive again, the saved position value can be read by the drive.

## Virtual multi-turn encoder

For a single-turn absolute encoder with position tracking activated ( $p29243 = 1$ ),  $p29244$  can be used to enter a virtual multi-turn resolution. This enables you to generate a virtual multi-turn encoder value from a single-turn encoder. The actual position value in  $r2521$  is limited to  $2^{32}$  places.

- When position tracking is deactivated ( $p29243 = 0$ ):  
Encoder actual position value range = actual single-turn resolution
- When position tracking is activated ( $p29243 = 1$ ):  
Encoder actual position value range = actual single-turn resolution  $\times$  virtual multi-turn resolution ( $p29244$ )

## Tolerance window

The tolerance window is preset to a quarter of one encoder revolution. After switching on the drive, the difference between the saved position and the actual position is determined. Based on the difference, the following situations apply:

- Difference being within the tolerance window:  
The position is reproduced based on the actual encoder value.
- Difference exceeding the tolerance window:  
The fault F7449 (for EPOS control mode) is output.

NOTICE
<p><b>Multi-turn position loss resulting from the axis movement when the drive is power-off</b></p> <p>When the drive is power-off, if the axis moves, the drive does not store the multi-turn position (when using the virtual multi-turn encoder). The actual position loses.</p> <ul style="list-style-type: none"><li>• Make sure that the motor holding brake function is enabled when you use the position tracking function.</li></ul>



## Position area extension

After the position tracking function is activated, the position area can be extended.

### Example

An absolute encoder that can represent eight encoder revolutions is used here.

- If the position tracking function is deactivated ( $p29243 = 0$ ), the position for  $\pm 4$  encoder revolutions can be reproduced.
- If you activate the position tracking function ( $p29243 = 1$ ), and set the virtual multi-turn  $p29244 = 24$ , and the gear ratio  $p29248/p29249 = 1$ , the position for  $\pm 12$  encoder revolutions ( $\pm 12$  load revolutions with load gear) can be reproduced.

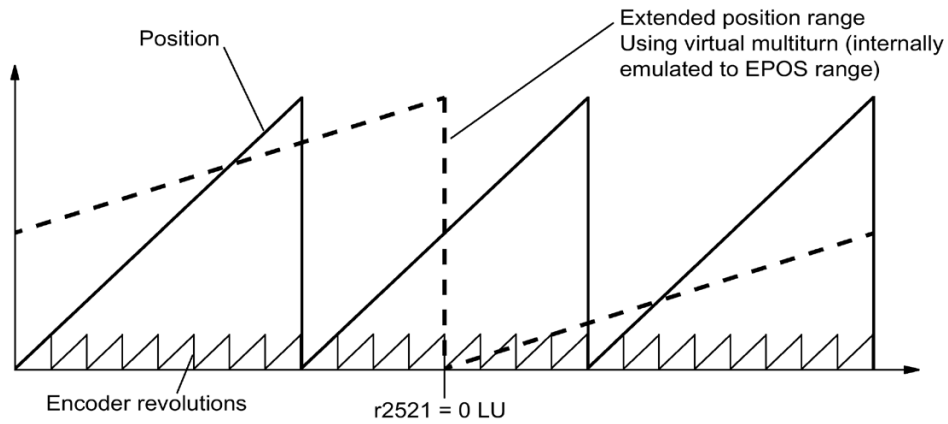

### Mechanical gear configuration

If you are using a mechanical gear between the motor and the load, and using an absolute encoder to process the position control, an offset occurs (depending on the gear ratio) between the zero position of the encoder and the load whenever encoder overflow occurs.

#### Note

If the ratio between the multi-turn resolution and the modulo range (p29246) is not an integer number, fault F7442 is output.

To make the ratio between the multi-turn resolution and the modulo range an integer number, observe the following formulas. The ratio  $v$  is calculated as follows:

- Motor encoder without position tracking (p29243 = 0):
  - For multi-turn encoders:
 
$$v = (4096 \times p29247 \times p29248) / (p29249 \times p29246)$$
  - For single-turn encoders:
 
$$v = (p29247 \times p29248) / (p29249 \times p29246)$$
- Motor encoder with position tracking (p29243 = 1):
 
$$v = (p29244 \times 29247) / p29246$$

#### Example

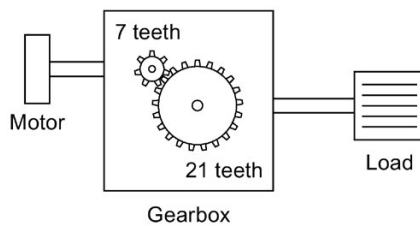

- Gear ratio = p29248 : p29249 = 1 : 3
- The absolute encoder can count eight encoder revolutions
- Position tracking function is deactivated (p29243 = 0)

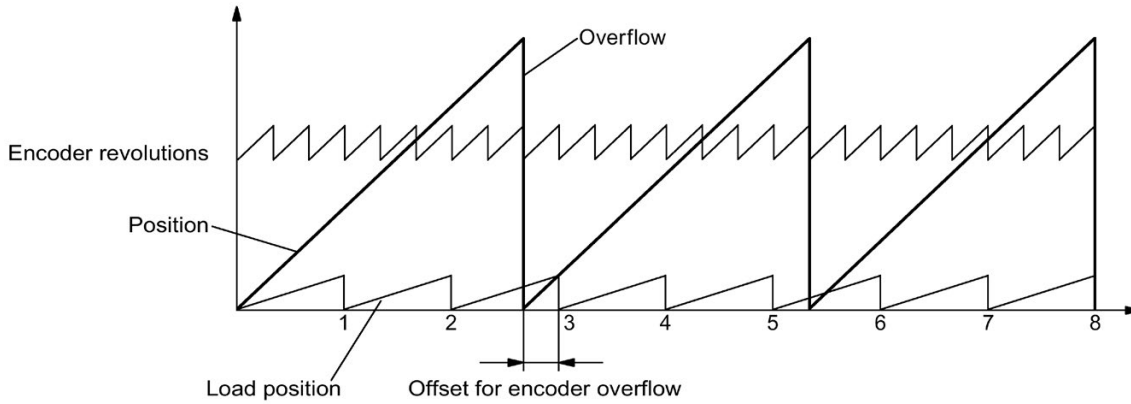

For each encoder overflow, there is a load-side offset of 1/3 load revolution, after three encoder overflows, the motor and load zero position coincide again. The position of the load can no longer be clearly reproduced after one overflow.

In this case, if you activate the position tracking function (set p29243 = 1), and set the virtual multi-turn p29244 = 24, the gear ratio is calculated with the encoder actual position value.

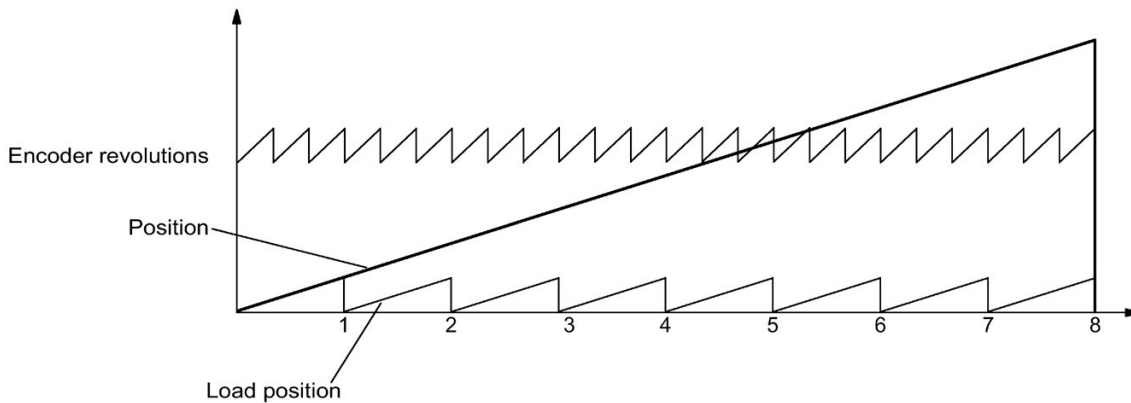

---

**Note**

Be sure to perform the "ABS" function again after you set p29243 to 1.

---

**Overview of important parameters**

- p29243            Position tracking activate
- p29244            Absolute encoder virtual rotary revolutions
- p29248            Mechanical gear: Numerator

7.5 Speed control (S)

- p29249 Mechanical gear: Denominator
- r2521[0] LR position actual value

## 7.5 Speed control (S)

### 7.5.1 Configuring speed setpoint

Eight sources in total are available for speed setpoint. You can select one of them with the combination of digital input signals SPD1, SPD2 and SPD3:

Digital signal			Torque limit
SPD3	SPD2	SPD1	
0	0	0	External analog speed setpoint (analog input 1)
0	0	1	Fixed speed setpoint 1 (p1001)
0	1	0	Fixed speed setpoint 2 (p1002)
0	1	1	Fixed speed setpoint 3 (p1003)
1	0	0	Fixed speed setpoint 4 (p1004)
1	0	1	Fixed speed setpoint 5 (p1005)
1	1	0	Fixed speed setpoint 6 (p1006)
1	1	1	Fixed speed setpoint 7 (p1007)

Refer to "DIs (Page 107)" for more information about the digital signals SPD1, SPD2 and SPD3.

#### 7.5.1.1 Speed control with external analog speed setpoint

In the S mode, when the digital input signals SPD1, SPD2 and SPD3 are all at low level (0), analog voltage from the analog input 1 is used as the speed setpoint.

The analog voltage from the analog input 1 corresponds to a parameterized speed value. Default speed value is rated motor speed. The analog voltage of 10 V corresponds to the maximum speed setpoint (V\_max) and this maximum speed setpoint can be specified by parameter p29060.

Parameter	Range	Default	Unit	Description
p29060	6 to 210000	3000	rpm	Maximum analog speed setpoint corresponding to 10 V



The relationship between the analog voltage and the speed setpoint is shown as follows:

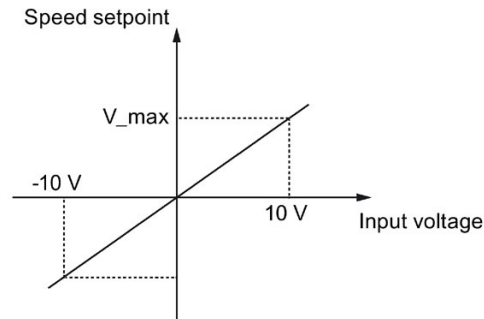

### Note

If the drive is working with external analog speed setpoint, the system continues to work automatically after you repower on the 24 VDC power supply which is shut off unexpectedly for the drive. In this case, do not touch the equipment.

## Offset adjustment for analog input 1

Offset exists for the input voltage from the analog input 1. You have two methods to adjust such offset:

- Automatic adjustment with BOP function: refer to "Adjusting AI offsets (Page 179)" for details.
- Manual input of an offset value (p29061)

Parameter	Range	Default	Unit	Description
p29061	-0.5000 to 0.5000	0.0000	V	Offset adjustment for analog input 1 (speed setpoint)

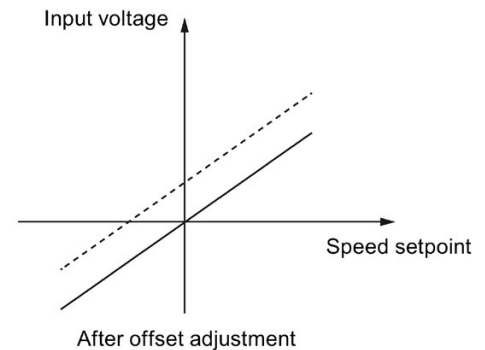
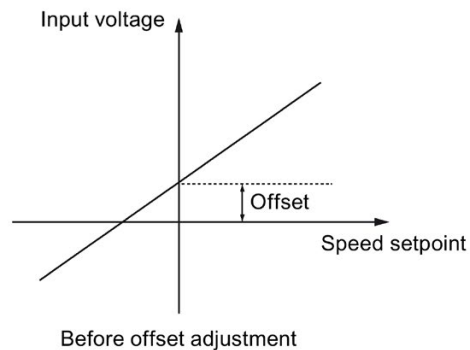

### 7.5.1.2 Speed control with fixed speed setpoint

#### Parameter settings

In the S mode, when at least one of the three digital input signals SPD1, SPD2 and SPD3 is at high level, one of the following parameter values is used as speed setpoint.

Parameter	Range	Default	Unit	Description	Digital input		
					SPD3	SPD2	SPD2
p1001	-210000 to 210000	0	rpm	Fixed speed setpoint 1	0	0	1
p1002	-210000 to 210000	0	rpm	Fixed speed setpoint 2	0	1	0
p1003	-210000 to 210000	0	rpm	Fixed speed setpoint 3	0	1	1
p1004	-210000 to 210000	0	rpm	Fixed speed setpoint 4	1	0	0
p1005	-210000 to 210000	0	rpm	Fixed speed setpoint 5	1	0	1
p1006	-210000 to 210000	0	rpm	Fixed speed setpoint 6	1	1	0
p1007	-210000 to 210000	0	rpm	Fixed speed setpoint 7	1	1	1

### 7.5.2 Direction and stop

Two digital input signals are used to control motor direction and run/stop.

- CWE: clockwise enable
- CCWE: counter-clockwise enable

The following table shows you in details:

Signal		Fixed torque setpoint	Analog torque setpoint		
CCWE	CWE		+ polarity	- polarity	0 V
0	0	0	0	0	0
0	1	CW	CW	CCW	0
1	0	CCW	CCW	CW	0
1	1	0	0	0	0

#### Note

In S mode or T mode, when the servo motor is ready to run, signal CWE or CCWE is a must to start running the motor.

For more information about signals CWE and CCWE, refer to "DIs (Page 107)".

### 7.5.3 Speed limit

Refer to "Speed limit (Page 199)" for details.

### 7.5.4 Torque limit

Refer to "Torque limit (Page 200)" for details.

### 7.5.5 Zero speed clamp

The function of zero speed clamp is used to stop motor and lock motor axis when motor speed setpoint is below a parameterized threshold level (p29075).

This function is available only when the analog input 1 is used as the source of speed setpoint. The digital input signal ZSCLAMP is used to activate this function. When both motor speed setpoint and motor actual speed are below the parameterized threshold level and signal ZSCLAMP is logic "1", the motor is locked. Drive exits from clamping state either when the motor speed setpoint is above the threshold level or when the signal ZSCLAMP is logic "0".

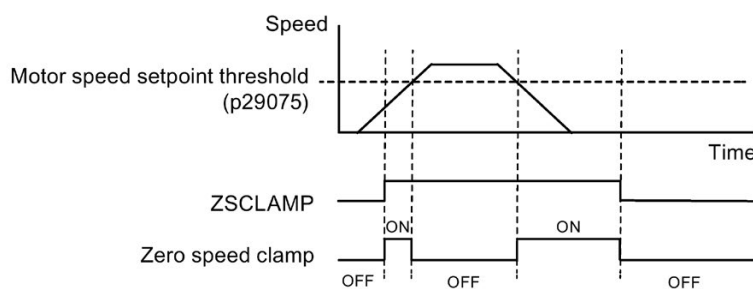

#### Parameter settings

Parameter	Range	Default	Unit	Description
p29075	0 to 200	200	rpm	Zero speed clamp threshold
p29060	6 to 210000	3000	%	Maximum analog speed setpoint corresponding to 10 V

#### DI configuration

Signal type	Signal name	Pin assignment	Setting	Description
DI	ZSCLAMP	To be assigned	1	When the motor speed setpoint is below zero speed clamp threshold, the motor is locked.
			0	No action

**Note**

When p29003=4 and CMODE is "1", the drive is working in speed control mode. In this case if ZSCLAMP is activated, the drive will switch to PTI control mode and PTI pulse input will lead motor running under PTI control mode.

**Note**

For more information about the signal ZSCLAMP, refer to "DIs (Page 107)".

### 7.5.6 Ramp-function generator

The ramp-function generator is used to limit acceleration in the event of abrupt setpoint changes and thus helps prevent load surges during drive operation.

The ramp-up time p1120 and ramp-down time p1121 can be used to set acceleration and deceleration ramps separately. This allows a smoothed transition in the event of setpoint changes.

The maximum speed p1082 is used as the reference value for calculating the ramp-up and ramp-down times.

You can see the properties of the ramp-function generator from the diagram below:

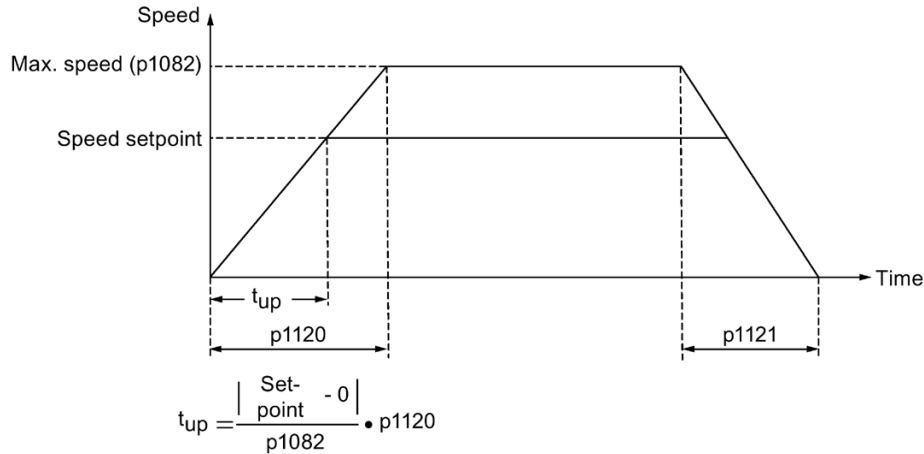

### S-curve ramp-function generator

You can also use the S-curve ramp-function generator by setting p1115 to 1. The S-curve ramp-function generator is realized with the following parameters:

- the acceleration (p1120) and deceleration (p1121) ramps
- the initial (p1130) and final (p1131) rounding-off times

You can see the properties of the S-curve ramp-function generator from the diagram below:

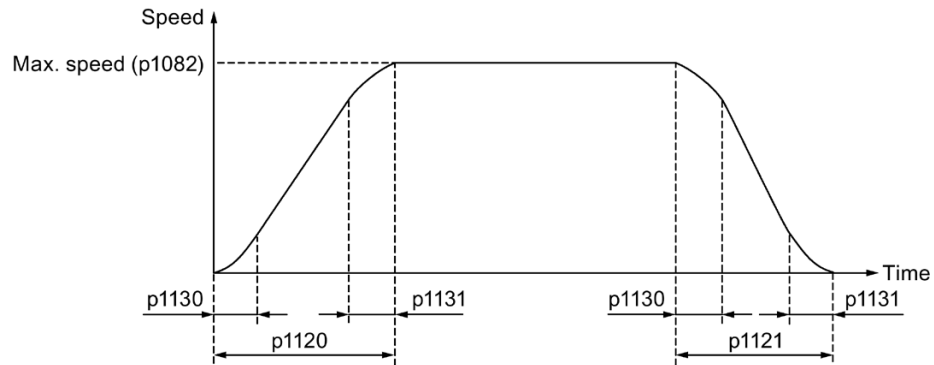

### Parameter settings

Parameter	Range	Default	Unit	Description
p1082	0 to 210000	1500	rpm	Maximum motor speed
p1115	0 to 1	0	-	Ramp-function generator selection
p1120	0 to 999999	1	s	Ramp-function generator ramp-up time
p1121	0 to 999999	1	s	Ramp-function generator ramp-down time
p1130	0 to 30	0	s	Ramp-function generator initial rounding-off time
p1131	0 to 30	0	s	Ramp-function generator final rounding-off time

## 7.6 Torque control (T)

### 7.6.1 300% overload capacity

SINAMICS V90 servo drives can work with 300% overload capacity for a specific time period. The following diagrams show in details:

#### SINAMICS V90 200 V servo drive

Without load

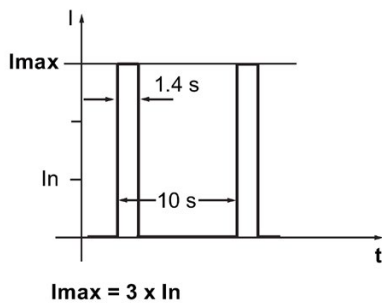

With load

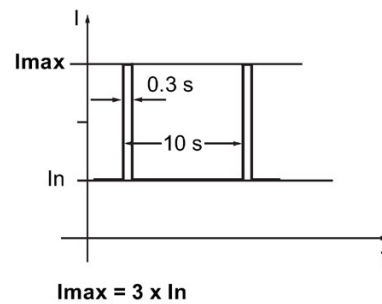

#### SINAMICS V90 400 V servo drive

Without load

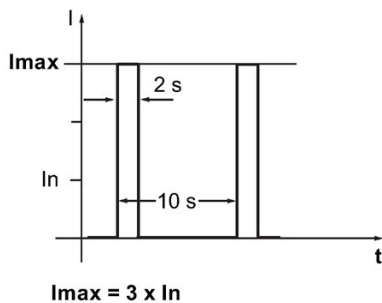

With load

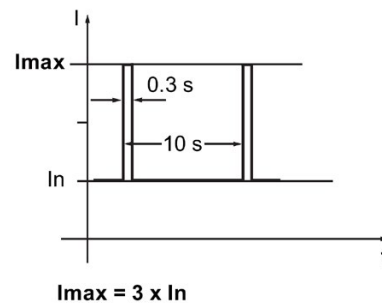

### 7.6.2 Torque setpoint

Two sources are available for torque setpoint:

- External setpoint: analog input 2
- Fixed setpoint: p29043

These two resources can be selected with the digital input signal TSET.

Signal	Level	Source of torque setpoint
TSET	0 (default)	Analog torque setpoint (analog input 2)
	1	Fixed torque setpoint (p29043)

Refer to "DIs (Page 107)" for detailed information about the signal TSET.

### 7.6.2.1 Torque control with external analog torque setpoint

In the T mode, when the digital input signal TSET is at low level, analog voltage from the analog input 2 is used as the torque setpoint.

The analog voltage from the analog input 2 corresponds to a parameterized torque value scaling (p29041[0]). If p29041[0] = 100%, analog input voltage of 10 V corresponds to rated torque; if p29041[0] = 50%, the analog input value of 10 V corresponds to 50% of the rated torque.

Parameter	Range	Default	Unit	Description
p29041[0]	0 to 100	100	%	Scaling for analog torque setpoint (corresponding to 10 V)

#### Note

The value of analog input 2 can be monitored through parameter p29351.

### Offset adjustment for analog input 2

Offset exists for the input voltage from the analog input 2. The motor can run at a very low speed even the current input voltage is 0 V. You have 2 methods to adjust such offset:

- Automatic adjustment with BOP function: refer to "Adjusting AI offsets (Page 179)" for details.
- Manual input of an offset value (p29042)

Parameter	Range	Default	Unit	Description
p29042	- 0.50 to 0.50	0	V	Offset adjustment for analog input 2 (torque setpoint)

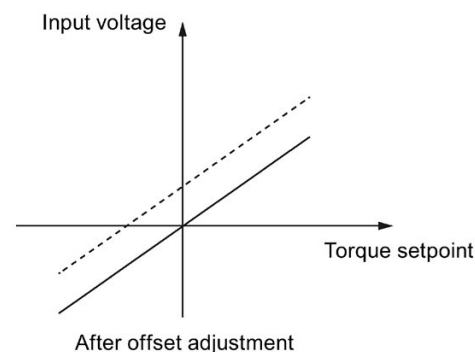
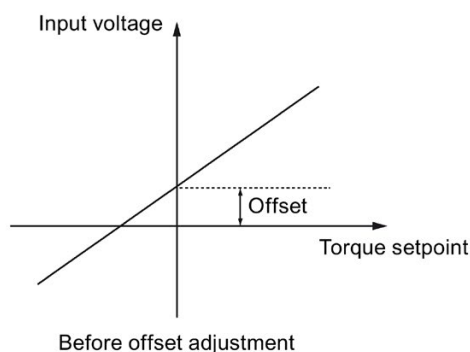

### 7.6.2.2 Torque control with fixed torque setpoint

#### Parameter settings

Parameter	Range	Default	Unit	Description
p29043	-100 to 100	0	%	Fixed torque setpoint

### 7.6.3 Direction and stop

Two digital input signals are used to control motor direction and run/stop:

- CWE: clockwise enable
- CCWE: counter-clockwise enable

The following table shows you in details:

Signal		Fixed torque setpoint	Analog torque setpoint		
CCWE	CWE		+ polarity	- polarity	0 V
0	0	0	0	0	0
0	1	CW	CW	CCW	0
1	0	CCW	CCW	CW	0
1	1	0	0	0	0

#### Note

In S mode or T mode, when the servo motor is ready to run, signal CWE or CCWE is a must to start running the motor.

For more information about the signals CWE and CCWE, refer to "DIs (Page 107)".

### 7.6.4 Speed limit

Refer to "Speed limit (Page 199)" for details.



## 7.7 Communicating with the PLC

The SINAMICS V90 supports communication with the PLC on the RS485 interface. You can parameterize whether the RS485 interface applies USS or Modbus RTU protocol. USS is the default bus setting. A shielded twisted pair cable is recommended for RS485 communication.

### 7.7.1 USS communication

The SINAMICS V90 can communicate with the PLC through an RS485 cable with the standard USS communication protocol. After the communication is established, you can change the position setpoint and speed setpoint through the USS communication protocol. The servo drive can also transmit the actual speed, torque, and alarm to the PLC through the USS communication protocol.

#### Telegram format

The telegram format is shown as follows:

STX	LGE	ADR	PKE	IND	PWE	PWE	BCC
-----	-----	-----	-----	-----	-----	-----	-----

**STX:** start of text

**LGE:** length

**ADR:** slave address

**PKE:** parameter ID

**IND:** sub-index

**PWE:** parameter value

**BCC:** block check character

#### Relevant parameters

You can access the following parameters by USS.

Parameter	Description	Parameter	Description
p1001	Fixed speed setpoint 1	r0020	Speed setpoint smoothed
p1002	Fixed speed setpoint 2	r0021	Actual speed smoothed
p1003	Fixed speed setpoint 3	r0026	DC link voltage smoothed
p1004	Fixed speed setpoint 4	r0027	Absolute actual current smoothed
p1005	Fixed speed setpoint 5	r0031	Actual torque smoothed
p1006	Fixed speed setpoint 6	r0032	Active power actual value smoothed
p1007	Fixed speed setpoint 7	r0034	Motor utilization thermal
p2617[0...7]	Fixed position setpoint	r0807	Master control active
p2618[0...7]	Speed of fixed position setpoint	r2521	LR position actual value
p2572	IPos maximum acceleration	r2556	LR position setpoint after setpoint smoothing
p2573	IPos maximum deceleration		

**Note**

There is no priority when BOP, V-ASSISTANT, and USS access the same parameter at the same time, the value of the parameter depends on the last access operation.

**Operating steps**

Main step		Sub step/comment
①	Configure the setup and program the PLC.	
②	Configure the RS485 bus address by parameter p29004.	The RS485 bus is used to transfer current absolute position of the servo drive to the upper controller/PLC. You can configure the slaver address from 1 to 31.
③	Select the USS communication protocol by parameter p29007.	<ul style="list-style-type: none"> <li>• p29007 = 0: no protocol</li> <li>• p29007 = 1: USS protocol</li> <li>• p29007 = 2: Modbus protocol</li> </ul>
④	Set the transmission baud rate by parameter p29009.	<ul style="list-style-type: none"> <li>• 5: 4800 baud</li> <li>• 6: 9600 baud</li> <li>• 7: 19200 baud</li> <li>• 8: 38400 baud</li> <li>• 9: 57600 baud</li> <li>• 10: 76800 baud</li> <li>• 11: 93750 baud</li> <li>• 12: 115200 baud</li> <li>• 13: 187500 baud</li> </ul>
⑤	Set control mode for the drive.	
⑥	Save the parameters and restart the drive.	
⑦	Access the parameters via USS.	<p>For IPos control mode, you can change the following parameters via USS:</p> <ul style="list-style-type: none"> <li>• p2617[0...7], p2618[0...7], p2572, p2573</li> </ul> <p>For S control mode, you can change the following parameter via USS:</p> <ul style="list-style-type: none"> <li>• p1001 to p1007</li> </ul> <p>Ten monitor parameters can be read by USS:</p> <ul style="list-style-type: none"> <li>• r0020, r0021, r0026, r0027, r0031, r0032, r0034, r0807, r2556, and r2521</li> </ul>

**Note**

The USS protocol communication libraries of S7-200, S7-200 SMART V1.0, and S7-1200 do not support the communication with the SINAMICS V90 servo drive.

## 7.7.2 Modbus communication

### 7.7.2.1 Overview

The SINAMICS V90 servo drive can communicate with the PLC through an RS485 cable by using the standard Modbus communication protocol. There are two ways of sending a message to a slave.

- Unicast mode (addresses 1 to 31): The master sends a message to a specific slave directly.
- Broadcast mode (address 0): The master sends a message to all slaves at the same time.

The broadcast mode cannot be used for an error request because all slaves cannot respond at once.

For the Modbus data format, V90 supports Modbus RTU while Modbus ASCII is not supported. Registers of the servo drive can be read by Modbus function code FC3 and written via Modbus function code FC6 (single register) or FC16 (multiple registers).

### Supported function codes

The SINAMICS V90 supports only three function codes. If a request with an unknown function code is received, an error message is returned.

#### FC3 - Read holding registers

When a message with FC = 0x03 is received, then four bytes of data are expected, that is, FC3 has four bytes of data:

- Two bytes for the starting address
- Two bytes for the number of registers

Byte 1	Byte 2	Byte 3	Byte 4	Byte 5	Byte 6	Byte 7	Byte 8
Address	FC (0x03)	Start address		Number of registers		CRC	
		High	Low	High	Low	High	Low

#### FC6 - Write single register

When a message with FC = 0x06 is received, then four bytes of data are expected, that is, FC6 has four bytes of data:

- Two bytes for the register address
- Two bytes for the register value

Byte 1	Byte 2	Byte 3	Byte 4	Byte 5	Byte 6	Byte 7	Byte 8
Address	FC (0x06)	Start address		New register value		CRC	
		High	Low	High	Low	High	Low

**FC16 - Write multiple registers**

When a message with FC = 0x10 is received, then 5 + N bytes of data are expected, that is, FC16 has 5 + N bytes of data:

- Two bytes for the starting address
- Two bytes for the number of registers
- One byte for the byte count
- N bytes for the register values

Byte 1	Byte 2	Byte 3	Byte 4	Byte 5	Byte 6	Byte 7	Byte 7 + N	Byte 8 + N	Byte 9 + N	Byte 10 + N
Ad- dress	FC (0x10)	Start address		Number of regis- ters		Num- ber of bytes	Register N value		CRC	
		High	Low	High	Low		High	Low	High	Low

**Mapping table**

The SINAMICS V90 servo drive supports the following registers. "R", "W", "R/W" in the column access stand for read, write, read/write.

Modbus register number	Description	Modbus access	Unit	Scaling factor	Range or On/Off text	Data/parameter
40100	Control word (PTI, IPos, S, T)	R/W	-	1	-	Process data 1, receive word, PZD1
40101	Speed setpoint (S)	R/W	-	0x4000 hex = 100% × motor rated speed	-	Process data 2, receive word, PZD2
40102	MDI position setpoint high word (IPos)	R/W	LU	1	-2147482648 to 2147482647	Process data 3, receive word, PZD3
40103	MDI position setpoint low word (IPos)	R/W	LU	1		Process data 4, receive word, PZD4
40104	MDI speed setpoint high word (IPos)	R/W	1000 LU/min	1	1 to 40000000	Process data 5, receive word, PZD5
40105	MDI speed setpoint low word (IPos)	R/W	1000 LU/min	1		Process data 6, receive word, PZD6
40110	Status word (PTI, IPos, S, T)	R	-	1	-	Process data 1, send word, PZD1
40111	Actual speed (PTI, IPos, S, T)	R	-	0x4000 hex = 100% × motor rated speed	-	Process data 2, send word, PZD2
40112	Actual position high word (PTI, IPos)	R	LU	1	-2147482648 to 2147482647	Process data 3, send word, PZD3
40113	Actual position low word (PTI, IPos)	R	LU	1		Process data 4, send word, PZD4
40114	Actual speed high word (PTI, IPos)	R	1000 LU/min	1	1 to 40000000	Process data 5, send word, PZD5

Modbus register number	Description	Modbus access	Unit	Scaling factor	Range or On/Off text	Data/parameter
40115	Actual speed low word (PTI, IPos)	R	1000 LU/min	1		Process data 6, send word, PZD6
40200	DO 1	R/W	-	1	HIGH/LOW	r0747.0
40201	DO 2	R/W	-	1	HIGH/LOW	r0747.1
40202	DO 3	R/W	-	1	HIGH/LOW	r0747.2
40203	DO 4	R/W	-	1	HIGH/LOW	r0747.3
40204	DO 5	R/W	-	1	HIGH/LOW	r0747.4
40205	DO 6	R/W	-	1	HIGH/LOW	r0747.5
40220	AO 1	R	%	100	-100.0 to 100.0	-
40221	AO 2	R	%	100	-100.0 to 100.0	-
40240	DI 1	R	-	1	HIGH/LOW	r0722.0
40241	DI 2	R	-	1	HIGH/LOW	r0722.1
40242	DI 3	R	-	1	HIGH/LOW	r0722.2
40243	DI 4	R	-	1	HIGH/LOW	r0722.3
40244	DI 5	R	-	1	HIGH/LOW	r0722.4
40245	DI 6	R	-	1	HIGH/LOW	r0722.5
40246	DI 7	R	-	1	HIGH/LOW	r0722.6
40247	DI 8	R	-	1	HIGH/LOW	r0722.7
40248	DI 9	R	-	1	HIGH/LOW	r0722.8
40249	DI 10	R	-	1	HIGH/LOW	r0722.9
40260	AI 1	R	%	100	-300.0 to 300.0	-
40261	AI 2	R	%	100	-300.0 to 300.0	-
40280/40281	Enable DI simulation (high part/low part)	R/W	-	1	HIGH/LOW	p0795
40282/40283	Setpoint DI simulation (high part/low part)	R/W	-	1	HIGH/LOW	p0796
40300	Power stack code number	R	-	1	0 to 32767	-
40301	V90 OA version	R	-	1	e.g. 104xx for V01.04.xx	p29018[0]/100
40320	Rated power of the power unit	R	kW	100	0.00 to 327.67	-
40321	Current limit	R/W	A	1	0.0 to 400.0	-
40322	Ramp-up time	R/W	s	100	0.0 to 650.0	p1120
40323	Ramp-down time	R/W	s	100	0.0 to 650.0	p1121
40324	Reference speed	R	rpm	1	6 to 32767	Motor rated speed
40325	Control mode	R/W	-	1	0 to 8	p29003
40326	Reference mode	R/W	-	1	0 to 4	p29240
40340	Speed setpoint	R	rpm	1	-16250 to 16250	r0020
40341	Actual speed value	R	rpm	1	-16250 to 16250	r0021
40344	DC-link voltage	R	V	1	0 to 32767	r0026

Modbus register number	Description	Modbus access	Unit	Scaling factor	Range or On/Off text	Data/parameter
40345	Actual current value	R	A	100	0 to 163.83	r0027
40346	Actual torque value	R	Nm	100	-325.00 to 325.00	r0031
40347	Actual active power	R	kW	100	0 to 327.67	r0032
40348	Energy consumption	R	kWh	1	0 to 32767	-
40349	Control priority	R	-	1	Manual/Auto	r0807
40350/40351	Position setpoint	R	LU	1	-2147482648 to 2147482647	r2556
40352/40353	Actual position value	R	LU	1	-2147482648 to 2147482647	r2521[0]
40354	Motor utilization	R	%	100	-320.00 to 320.00	r0034
40400	Failure number, index 0	R	-	1	0 to 65535	-
40401	Failure number, index 1	R	-	1	0 to 65535	-
40402	Failure number, index 2	R	-	1	0 to 65535	-
40403	Failure number, index 3	R	-	1	0 to 65535	-
40404	Failure number, index 4	R	-	1	0 to 65535	-
40405	Failure number, index 5	R	-	1	0 to 65535	-
40406	Failure number, index 6	R	-	1	0 to 65535	-
40407	Failure number, index 7	R	-	1	0 to 65535	-
40408	Alarm number	R	-	1	0 to 65535	-
40601	DS47 Control	R/W	-	-	-	-
40602	DS47 header	R/W	-	-	-	-
40603	DS47 data 1	R/W	-	-	-	-
...	...					
40722	DS47 data 120	R/W	-	-	-	-
40800/40801	Fixed position setpoint 1	R/W	LU	1	-2147482648 to 2147482647	p2617[0]
40802/40803	Fixed position setpoint 2	R/W	LU	1	-2147482648 to 2147482647	p2617[1]
40804/40805	Fixed position setpoint 3	R/W	LU	1	-2147482648 to 2147482647	p2617[2]
40806/40807	Fixed position setpoint 4	R/W	LU	1	-2147482648 to 2147482647	p2617[3]
40808/40809	Fixed position setpoint 5	R/W	LU	1	-2147482648 to 2147482647	p2617[4]
40810/40811	Fixed position setpoint 6	R/W	LU	1	-2147482648 to 2147482647	p2617[5]
40812/40813	Fixed position setpoint 7	R/W	LU	1	-2147482648 to 2147482647	p2617[6]
40814/40815	Fixed position setpoint 8	R/W	LU	1	-2147482648 to 2147482647	p2617[7]
40840/40841	Speed of the fixed position 1	R/W	1000 LU/min	1	1 to 40000000	p2618[0]

Modbus register number	Description	Modbus access	Unit	Scaling factor	Range or On/Off text	Data/parameter
40842/40843	Speed of the fixed position 2	R/W	1000 LU/min	1	1 to 40000000	p2618[1]
40844/40845	Speed of the fixed position 3	R/W	1000 LU/min	1	1 to 40000000	p2618[2]
40846/40847	Speed of the fixed position 4	R/W	1000 LU/min	1	1 to 40000000	p2618[3]
40848/40849	Speed of the fixed position 5	R/W	1000 LU/min	1	1 to 40000000	p2618[4]
40850/40851	Speed of the fixed position 6	R/W	1000 LU/min	1	1 to 40000000	p2618[5]
40852/40853	Speed of the fixed position 7	R/W	1000 LU/min	1	1 to 40000000	p2618[6]
40854/40855	Speed of the fixed position 8	R/W	1000 LU/min	1	1 to 40000000	p2618[7]
40880/40881	IPos maximum acceleration	R/W	1000 LU/s <sup>2</sup>	1	1 to 2000000	p2572
40882/40883	IPos maximum deceleration	R/W	1000 LU/s <sup>2</sup>	1	1 to 2000000	p2573
40884/40885	IPos jerk limiting	R/W	1000 LU/s <sup>3</sup>	1	1 to 100000000	p2574
40886/40887	IPos reference point coordinate value	R/W	LU	1	-2147482648 to 2147482647	p2599
40900	Fixed speed setpoint 1	R/W	-	0x4000 hex = 100% × motor rated speed	-210000.000 to 210000.00	p1001
40901	Fixed speed setpoint 2	R/W	-	0x4000 hex = 100% × motor rated speed	-210000.000 to 210000.00	p1002
40902	Fixed speed setpoint 3	R/W	-	0x4000 hex = 100% × motor rated speed	-210000.000 to 210000.00	p1003
40903	Fixed speed setpoint 4	R/W	-	0x4000 hex = 100% × motor rated speed	-210000.000 to 210000.00	p1004
40904	Fixed speed setpoint 5	R/W	-	0x4000 hex = 100% × motor rated speed	-210000.000 to 210000.00	p1005
40905	Fixed speed setpoint 6	R/W	-	0x4000 hex = 100% × motor rated speed	-210000.000 to 210000.00	p1006
40906	Fixed speed setpoint 7	R/W	-	0x4000 hex = 100% × motor rated speed	-210000.000 to 210000.00	p1007
40934	MDI acceleration override	R/W	%	100	0.1 to 100	p2692
40935	MDI deceleration override	R/W	%	100	0.1 to 100	p2693
40950	Fixed torque setpoint	R/W	%	100	-100 to 100	p29043

Modbus register number	Description	Modbus access	Unit	Scaling factor	Range or On/Off text	Data/parameter
40960/40961	Number of pulses per revolution	R/W	-	1	0 to 16777215	p29011
40962/40963	Numerator of electronic gear 0	R/W	-	1	1 to 10000	p29012[0]
40964/40965	Numerator of electronic gear 1	R/W	-	1	1 to 10000	p29012[1]
40966/40967	Numerator of electronic gear 2	R/W	-	1	1 to 10000	p29012[2]
40968/40969	Numerator of electronic gear 3	R/W	-	1	1 to 10000	p29012[3]
40970/40971	Denominator of the electronic gear	R/W	-	1	1 to 10000	p29013

### Parameter scaling

Due to the limits of the integer data in the Modbus protocol, it is necessary to convert the drive parameters before transmitting them. This is done by scaling, so that a parameter, which has a position after decimal point, is multiplied by a factor, to get rid of the fractional part. The scaling factor is as defined in the above table.

### 7.7.2.2 Cyclic communication

#### Operating steps

Description		Comment
①	Configure the RS485 bus address by parameter p29004.	You can configure the slave address from 1 to 31.
②	Select the communication protocol by parameter p29007.	<ul style="list-style-type: none"> <li>• p29007 = 0: No protocol</li> <li>• p29007 = 1: USS protocol</li> <li>• p29007 = 2: Modbus protocol</li> </ul>
③	Select the command and setpoint source by parameter p29008.	<ul style="list-style-type: none"> <li>• p29008 = 1: Setpoint and control word from Modbus PZD</li> <li>• p29008 = 2: No control word.</li> </ul>
④	Set the transmission baud rate by parameter p29009.	<ul style="list-style-type: none"> <li>• 5: 4800 baud</li> <li>• 6: 9600 baud</li> <li>• 7: 19200 baud</li> <li>• 8: 38400 baud</li> <li>• 9: 57600 baud</li> <li>• 10: 76800 baud</li> <li>• 11: 93750 baud</li> <li>• 12: 115200 baud</li> <li>• 13: 187500 baud</li> </ul>



Description	Comment
⑤ Set the monitor time for Modbus by parameter p29019.	Sets the monitoring time to monitor the process data received via the RS485 interface. If no process data is received within this time, then F1910 is output. The default value of p29019 is 0. If p29019 = 0, monitoring is deactivated.
⑥ Set control mode for the drive by p29003.	
⑦ Save the parameters and restart the drive.	
⑧ Configure the PLC parameters.	<b>Note:</b> Keep the PLC baud rate the same as the drive setting. Set even parity check for the PLC.
⑨ Set a way for PLC sending message to slaves.	<b>Note:</b> For broadcast mode, you need to set the slave address to 0 on the PLC side. For unicast mode, you need to set the desired target slave address on the PLC side. For example, if you want to send the message to slave 1, you need to set the slave address to 1 on the PLC side.
⑩ Write the control word via PLC.	<b>Note:</b> Bit 10 of the register 40100 must be set to 1 to allow the PLC to control the drive. You need to trigger a rise edge for OFF1 to enable SON status for the motor, and OFF2 and OFF3 must be set to 1. The step must be executed when you enable SON for the first time.
⑪ Write the setpoint and read the status word via PLC.	

### Example 1

This example shows the operating procedures when we use the setpoint and control word from Modbus (p29008 = 1) as the Modbus control source in S control mode.

1. Set RS485 bus address for the drive.
  - p29004 = 1
2. Select the Modbus protocol by p29007.
  - p29007 = 2
3. Select Modbus control source by p29008.
  - p29008 = 1
4. Set the transmission baud rate by p29009.
  - p29009 = 8 (38400 baud)
5. Set the drive work mode to S control mode.
6. Save the parameters and restart the drive.

7. Configure the PLC parameters.

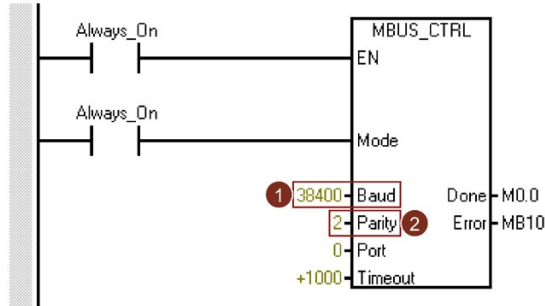

**Note:**

Keep the PLC baud rate the same as the drive setting.  
Set even parity check for the PLC (parity = 2).

8. Set a way for PLC sending message to slaves. Here we use the unicast mode and we only want to send the message to slave 1.

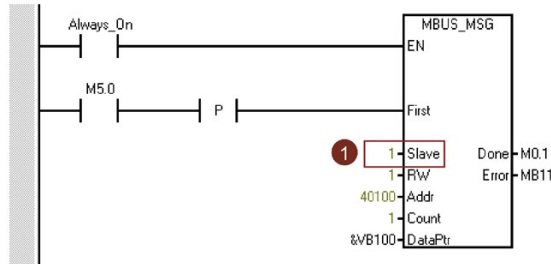

**Note:**

If you want to send the message to all slaves, you need to set the slave address to 0 to use the broadcast mode.

9. Write the control word you desired via the register 40100.

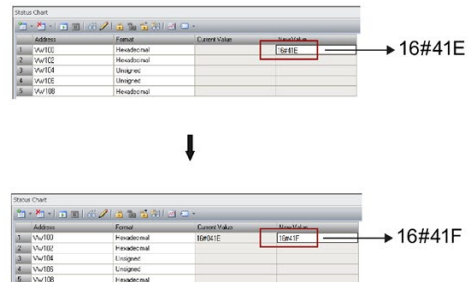
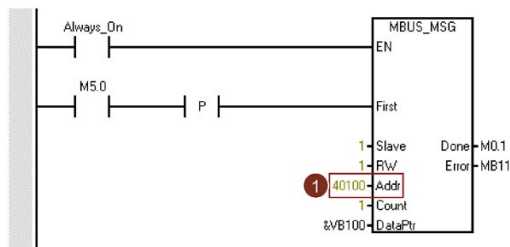

**Note:**

Bit 10 of the register 40100 must be set to 1 to allow the PLC to control the drive.  
You need to trigger a rise edge for OFF1 to enable SON status for the motor, and OFF2 and OFF3 must be set to 1. The step must be executed when you enable SON for the first time.

For example, we write 0x41E to the register 40100 firstly and then write 0x41F to the register. The motor now is in SON status. You can check the control word definition table below to see the meaning of "0x41E" and "0x41F".

10. Write the speed setpoint via the register 40101.

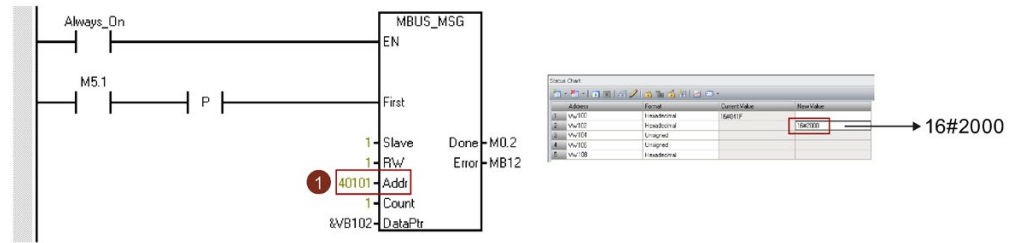

**Note:**

You can calculate the actual speed value with the scale factor. Value 0x4000 represents the value of 100% × motor rated speed. Therefore, 0x2000 represents half of the motor rated speed.

**Example 2**

This example shows the operating procedures when no control word (p29008 = 2) is used in S control mode.

- Set RS485 bus address for the drive.
  - p29004 = 1
- Select the Modbus protocol by p29007.
  - p29007 = 2
- Select Modbus control source by p29008.
  - p29008 = 2
- Set the transmission baud rate by p29009.
  - p29009 = 8 (38400 baud)
- Set the drive work mode to S control mode.
- Save the parameters and restart the drive.
- Configure the PLC parameters.

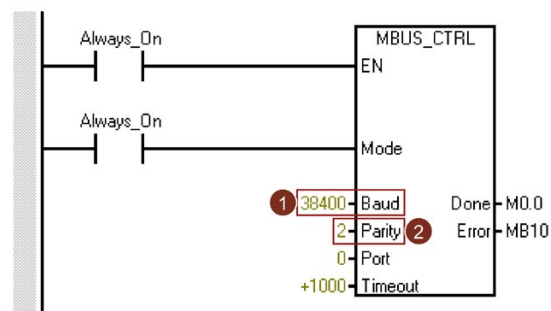

**Note:**

Keep the PLC baud rate the same as the drive setting.  
Set even parity check for the PLC (parity = 2).

8. Set a way for PLC sending message to slaves. Here we use the unicast mode and we only want to send the message to slave 1.

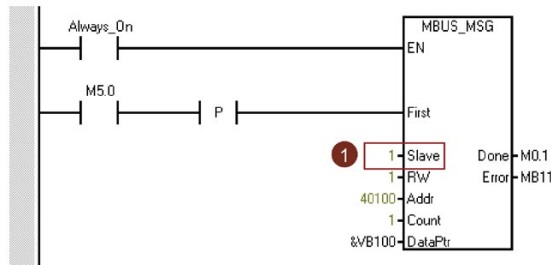

**Note:**

If you want to send the message to all slaves, you need to set the slave address to 0 to use the broadcast mode.

9. Set the motor to SON status.  
You can servo on the motor with external terminal DI signal or simulated DI signal (registers 40280/40281 and 40282/40283).
10. Write the speed setpoint via the register 40101.

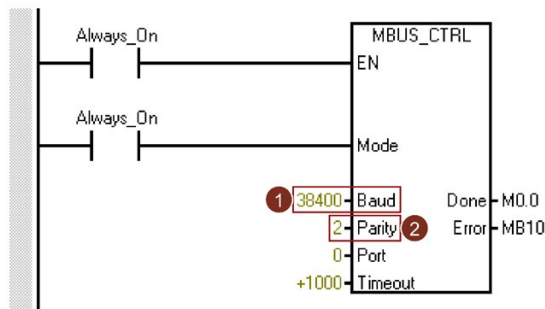

**Note:**

You can calculate the actual speed value with the scale factor. Value 0x4000 represents the value of 100% × motor rated speed. Therefore, 0x2000 represents half of the motor rated speed.

**Example 3**

This example shows the operating procedures when we use the setpoint and control word from Modbus (p29008 = 1) as the Modbus control source in IPos control mode.

1. Set RS485 bus address for the drive.
  - p29004 = 1
2. Select the Modbus protocol by p29007.
  - p29007 = 2
3. Select Modbus control source by p29008.
  - p29008 = 1
4. Set the transmission baud rate by p29009.
  - p29009 = 8 (38400 baud)
5. Set the drive work mode to IPos control mode.

6. Save the parameters and restart the drive.
7. Configure the PLC parameters.

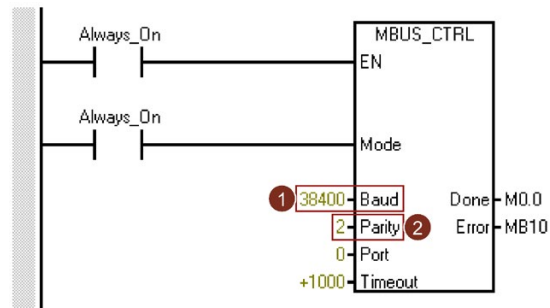

**Note:**

Keep the PLC baud rate the same as the drive setting.  
Set even parity check for the PLC (parity = 2).

8. Set a way for PLC sending message to slaves. Here we use the unicast mode and we only want to send the message to slave 1.

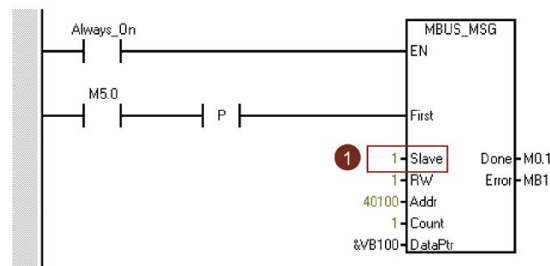

**Note:**

If you want to send the message to all slaves, you need to set the slave address to 0 to use the broadcast mode.

9. Write the control word you desired via the register 40100.

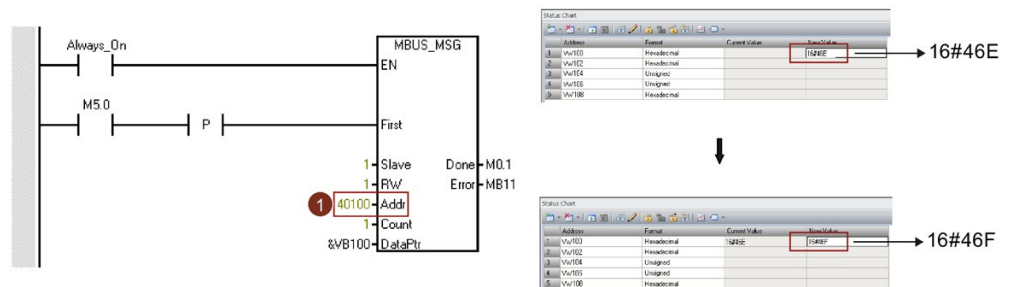

**Note:**

Bit 10 of the register 40100 must be set to 1 to allow the PLC to control the drive. You need to trigger a rise edge for OFF1 to enable SON (0→1) status for the motor, and OFF2 and OFF3 must be set to 1. The step must be executed when you enable SON for the first time.

For example, we write 0x46E to the register 40100 firstly and then write 0x46F to the register. The motor now is in SON status. You can check the control word definition table below to see the meaning of "0x46E" and "0x46F".

10. Implement referencing for the drive.  
Keep the drive in SON status and implement referencing by writing the control word 40100.
11. Write the position setpoint, speed setpoint, acceleration override, and deceleration override via the registers 40102, 40103, 40104, 40105, 40934 and 40935.

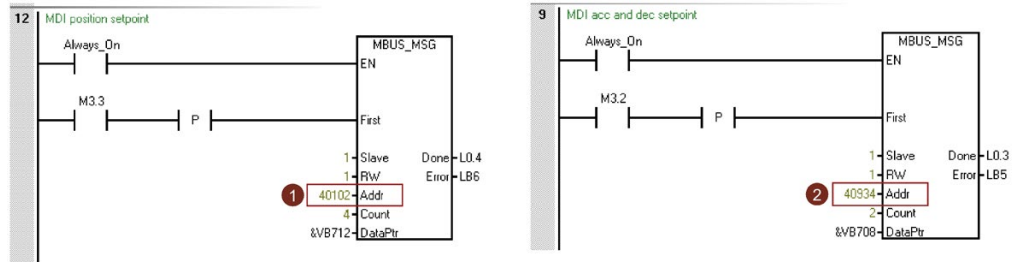

Process data overview

Control mode	PTI	IPos	S	T	
Control data	40100	PTI mode control word	IPos mode control word	S mode control word	T mode control word
	40101	-	-	Speed setpoint	-
	40102	-	Position setpoint high word	-	-
	40103	-	Position setpoint low word	-	-
Status data	40110	Status word	Status word	Status word	Status word
	40111	Actual speed	Actual speed	Actual speed	Actual speed
	40112	Actual position high word	Actual position high word	-	-
	40113	Actual position low word	Actual position low word	-	-

Definition of the register 40100

Bit	PTI control mode		IPos control mode	
	Signals	Description	Signals	Description
0	SON_OFF1	Rising edge to enable SON (pulses can be enabled). 0: OFF1 (braking with ramp-function generator, then pulse cancellation, ready to power up)	SON_OFF1	Rising edge to enable SON (pulses can be enabled). 0: OFF1 (braking with ramp-function generator, then pulse cancellation, ready to power up)
1	OFF2	1: No OFF2 (enable is possible) 0: OFF2 (immediate pulse cancellation and power on inhibit)	OFF2	1: No OFF2 (enable is possible) 0: OFF2 (immediate pulse cancellation and power on inhibit)

Bit	PTI control mode		IPos control mode	
	Signals	Description	Signals	Description
2	OFF3	1: No OFF3 (enable is possible) 0: OFF3 (fast braking then pulse cancellation and power on inhibit)	OFF3	1: No OFF3 (enable is possible) 0: OFF3 (fast braking then pulse cancellation and power on inhibit)
3	OPER	1: Enable operation (pulses can be enabled) 0: Inhibit operation (cancel pulses)	OPER	1: Enable operation (pulses can be enabled) 0: Inhibit operation (cancel pulses)
4	Reserved	-	SETP_ACC	Rising edge to accept MDI setpoint
5	Reserved	-	TRANS_TY PE SE	1: Accept new setpoint immediately 0: Accept on rising edge of SETP_ACC
6	Reserved	-	POS_TYP	1: Absolute positioning 0: Relative positioning
7	RESET	Reset faults	RESET	Reset faults
8	Reserved	-	Reserved	-
9	Reserved	-	Reserved	-
10	PLC	Enable master control from the PLC	PLC	Enable master control from the PLC
11	Reserved	-	Reserved	-
12	Reserved	-	Reserved	-
13	Reserved	-	SREF	Start referencing (act as REF for reference mode 0)
14	Reserved	-	Reserved	-
15	Reserved	-	Reserved	-

Bit	S control mode		T control mode	
	Signals	Description	Signals	Description
0	SON_OFF1	Rising edge to enable SON (pulses can be enabled). 0: OFF1 (braking with ramp-function generator, then pulse cancellation, ready to power up)	SON_OFF1	Rising edge to enable SON (pulses can be enabled).
1	OFF2	1: No OFF2 (enable is possible) 0: OFF2 (immediate pulse cancellation and power on inhibit)	OFF2	1: No OFF2 (enable is possible) 0: OFF2 (immediate pulse cancellation and power on inhibit)
2	OFF3	1: no OFF3 (enable is possible) 0: OFF3 (fast braking then pulse cancellation and power on inhibit)	OFF3	1: no OFF3 (enable is possible) 0: OFF3 (fast braking then pulse cancellation and power on inhibit)
3	OPER	1: Enable operation (pulses can be enabled) 0: Inhibit operation (cancel pulses)	OPER	1: Enable operation (pulses can be enabled) 0: Inhibit operation (cancel pulses)
4	EN_RAMP	1: Operating condition (the ramp function generator can be enabled) 0: Inhibit ramp function generator (set the ramp function generator output to zero)	Reserved	-
5	Reserved	-	Reserved	-

Bit	S control mode		T control mode	
	Signals	Description	Signals	Description
6	Reserved	-	Reserved	-
7	RESET	Reset faults	RESET	Reset faults
8	Reserved	-	Reserved	-
9	Reserved	-	Reserved	-
10	PLC	Enable master control from the PLC	PLC	Enable master control from the PLC
11	Rev	Direction of rotation reversal	Reserved	-
12	Reserved	-	Reserved	-
13	Reserved	-	Reserved	-
14	Reserved	-	Reserved	-
15	Reserved	-	Reserved	-

**Note**

The following signals are occupied by Modbus control word when you use the setpoint and control word from Modbus as the Modbus control source (p29008 = 1). They can only be enabled by Modbus control word while cannot be enabled by external DI terminals.

- PTI control mode: SON
- IPos control mode: SON, SREF (REF for reference mode 0)
- S control mode: SON, CWE/CCWE
- T control mode: SON

**Note**

In IPos control mode, when the relative positioning mode is selected, the method for accepting MDI setpoint must be a rising edge (bit 5 = 0); otherwise, fault F7488 occurs.

**Note**

In IPos control mode, when you implement the absolute positioning for the modular axis with Modbus, you can select the MDI direction with parameter p29230.

**Note**

In T control mode, the motor cannot be stopped with OFF1 via Modbus.

**Note**

All the reserved bits in register 40100 must be set to 0.



## Definition of register 40110

Bit	PTI, IPos, S and T control modes	
	Signals	Description
0	RDY	Servo ready
1	FAULT	Fault status
2	INP	In-position signal
3	ZSP	Zero speed detection
4	SPDR	Speed reached
5	TLR	Torque limit reached
6	SPLR	Speed limit reached
7	MBR	Motor holding brake
8	OLL	Overload level reached
9	WARNING 1	Warning 1 condition reached
10	WARNING 2	Warning 2 condition reached
11	REFOK	Referenced
12	MODE 2	In the second control mode
13	Reserved	-
14	Reserved	-
15	Reserved	-

## DI simulation

The digital input signals can be simulated by Modbus with registers 40281 and 40283.

Digital input	DI1	DI2	DI3	DI4	DI5	DI6	DI7	DI8	DI9	DI10
Register 40281 (p0795)	Bit 0	Bit 1	Bit 2	Bit 3	Bit 4	Bit 5	Bit 6	Bit 7	Bit 8	Bit 9
Register 40283 (p0796)	Bit 0	Bit 1	Bit 2	Bit 3	Bit 4	Bit 5	Bit 6	Bit 7	Bit 8	Bit 9

- Set the simulation mode for DIs with register 40281  
Bit 0 to bit 9 of register 40281 can be used to set the simulation mode for DI1 to DI 10. For example, if you want to simulate DI1 with Modbus, you need to set bit 0 = 1 for register 40281.
- Set the setpoint for DIs with register 40283  
Bit 0 to bit 9 of register 40283 can be used to set the setpoint for the simulated DI signals. After the DI simulation mode is set, you can set the setpoint for a DI signal with register 40283 to enable the DI signal. For example, if you have set bit 0 = 1 for register 40281, to enable signal DI1, you need to set the trigger condition (rising edge or high level) for bit 0 of register 40283.

**DI simulation example in S control mode**

In S control mode, the default digital input signal assignment is as follows:

Digital input	DI1	DI2	DI3	DI4	DI5	DI6	DI7	DI8	DI9	DI10
Signal	SON	REST	CWL	CCWL	CWE	CCWE	SPD1	SPD2	EMGS	C-MODE
Register 40281 (p0795)	Bit 0	Bit 1	Bit 2	Bit 3	Bit 4	Bit 5	Bit 6	Bit 7	Bit 8	Bit 9
Register 40283 (p0796)	Bit 0	Bit 1	Bit 2	Bit 3	Bit 4	Bit 5	Bit 6	Bit 7	Bit 8	Bit 9

For more information about the DI assignment, refer to "Digital inputs/outputs (DIs/DOs) (Page 106)".

- Set the simulation mode for DI1

To simulate DI1 with Modbus, you need to set bit 0 = 1 for register 40281.

- Set the setpoint for DI1

After the simulation mode of DI1 is set, you can set the setpoint for DI1 with register 40283 to enable the DI signal.

In S control mode, DI1 is assigned with SON by default, so we need to trigger a rising edge to enable the SON signal. Set bit 0 = 0 for register 40283 and then set the bit to 1. A rising edge is triggered. The motor is now in "S ON" state.

**7.7.2.3 Acyclic communication**

The SINAMICS V90 servo drive supports acyclic communication via data set 47.

The maximum data length per request is 240 bytes.

**Note**

**Values in italics**

Values in italics in the following tables mean that you have to adjust these values for a specific request.

**Data block setting**

**Reading parameter values**

The table below formats a request to read parameters.

Data block	Byte n	Bytes n + 1	n
Header	Reference <i>00 hex ... FF hex</i>	01 hex: Read job	0
	02 hex (ID of drive objects, at V90 always = 2)	Number of parameters (m)	2
Address, parameter 1	Attribute <i>10 hex: Parameter value</i>	Number of the indices <i>00 hex ... EA hex</i> (For parameters without index: 00 hex)	4
	Parameter number <i>0001 hex ... FFFF hex</i>		6
	Number of the 1st Index <i>0000 hex ... FFFF hex</i> (for parameters without index: 0000 hex)		8
	...		...

Data block	Byte n	Bytes n + 1	n
Address, parameter 2	...		...
...	...		...
Address, parameter m	...		...

The table below formats the drive response to a read request.

Data block	Byte n	Bytes n + 1	n
<b>Header</b>	<b>Reference</b> (identical to a read request)	<b>01 hex:</b> Drive has executed the read request. <b>81 hex:</b> Drive was not able to completely execute the read request.	0
	<b>02 hex</b> (ID of drive objects, at V90 always = 2)	<b>Number of parameters (m)</b> (identical to the read request)	2
<b>Values, parameter 1</b>	<b>Format</b> <i>02 hex:</i> Integer8 <i>03 hex:</i> Integer16 <i>04 hex:</i> Integer32 <i>05 hex:</i> Unsigned8 <i>06 hex:</i> Unsigned16 <i>07 hex:</i> Unsigned32 <i>08 hex:</i> FloatingPoint <i>0A hex:</i> OctetString <i>0D hex:</i> TimeDifference <i>34 hex:</i> TimeOfDay without date indication <i>35 hex:</i> TimeDifference with date indication <i>36 hex:</i> TimeDifference without date indication <i>41 hex:</i> Byte <i>42 hex:</i> Word <i>43 hex:</i> Double word <i>44 hex:</i> Error	<b>Number of index values</b> or - for a negative response - <b>number of error values</b>	4
	<b>Value of the 1st Index</b> or - for a negative response- <b>Error value 1</b> You can find the error values in the table at the end of this section.		6
	...		...
<b>Values, parameter 2</b>	...		
...	...		
<b>Values, parameter m</b>	...		

### Changing parameter values

The table below formats a request to change parameters.

Data block	Byte n	Bytes n + 1	n
<b>Header</b>	<b>Reference</b> <i>00 hex ... FF hex</i>	<b>02 hex:</b> Change request	0
	<b>02 hex</b> (ID of drive objects, at V90 always = 2)	<b>Number of parameters (m)</b> <i>01 hex ... 27 hex</i>	2
<b>Address, parameter 1</b>	<b>10 hex:</b> Parameter value	<b>Number of indices</b> <i>00 hex ... EA hex</i> (00 hex and 01 hex are equivalents)	4
	<b>Parameter number</b> <i>0001 hex ... FFFF hex</i>		6
	<b>Number of the 1st Index</b> <i>0001 hex ... FFFF hex</i>		8
	...		...
<b>Address, parameter 2</b>	...		

7.7 Communicating with the PLC

Data block	Byte n	Bytes n + 1	n
...	...		...
Address, parameter m	...		
Values, parameter 1	<b>Format</b> <i>02 hex</i> : Integer 8 <i>03 hex</i> : Integer 16 <i>04 hex</i> : Integer 32 <i>05 hex</i> : Unsigned 8 <i>06 hex</i> : Unsigned 16 <i>07 hex</i> : Unsigned 32 <i>08 hex</i> : Floating Point <i>0A hex</i> : Octet String <i>0D hex</i> : Time Difference <i>34 hex</i> : TimeOfDay without date indication <i>35 hex</i> : TimeDifference with date indication <i>36 hex</i> : TimeDifference without date indication <i>41 hex</i> : Byte <i>42 hex</i> : Word <i>43 hex</i> : Double word	<b>Number of index values</b> <i>00 hex ... EA hex</i>	
	<b>Value of the 1st Index</b> ...		
Values, parameter 2	...		
...	...		
Values, parameter m	...		

The table below formats the response when the drive has executed the change request.

Data block	Byte n	Bytes n + 1	n
Header	<b>Reference</b> (identical to a change request)	<b>02 hex</b> (change request successful)	0
	<b>02 hex</b> (ID of drive objects, at V90 always = 2)	<b>Number of parameters</b> (identical to a change request)	2

The table below formats the response when the drive was not able to completely execute the change request.

Data block	Byte n	Bytes n + 1	n
Header	<b>Reference</b> (identical to a change request)	<b>82 hex</b> : (Drive was not able to completely execute the write request)	0
	<b>02 hex</b> (ID of drive objects, at V90 always = 2)	<b>Number of parameters</b> (identical to a change request)	2
Values, parameter 1	<b>Format</b> <i>40 hex</i> : Zero (change request for this data block executed) <i>44 hex</i> : Error (change request for this data block not executed)	<b>Number of error values</b> <i>00 hex</i> <i>01 hex or 02 hex</i>	4
	Only for "Error" - <b>error value 1</b> You can find the error values in the table at the end of this section.		6
	Only for "Error" - <b>error value 2</b> Error value 2 is either zero, or it contains the number of the first index where the error occurred.		8
Values, parameter 2	...		

Data block	Byte n	Bytes n + 1	n
...	...		...
Values, parameter m	...		

## Error values

See the table below for error values in the parameter response.

Error value 1	Meaning
00 hex	<b>Illegal parameter number</b> (access to a parameter that does not exist)
01 hex	<b>Parameter value cannot be changed</b> (change request for a parameter value that cannot be changed)
02 hex	<b>Lower or upper value limit exceeded</b> (change request with a value outside the value limits)
03 hex	<b>Incorrect subindex</b> (access to a parameter index that does not exist)
04 hex	<b>No array</b> (access with a subindex to non-indexed parameters)
05 hex	<b>Incorrect data type</b> (change request with a value that does not match the data type of the parameter)
06 hex	<b>Setting not permitted, only resetting</b> (change request with a value not equal to 0 without permission)
07 hex	<b>Descriptive element cannot be changed</b> (change request to a descriptive element that cannot be changed)
09 hex	<b>Description data not available</b> (access to a description that does not exist, parameter value is available)
0B hex	<b>No master control</b> (change request but with no master control)
0F hex	<b>Text array does not exist</b> (although the parameter value is available, the request is made to a text array that does not exist)
11 hex	<b>Request cannot be executed due to the operating state</b> (access is not possible for temporary reasons that are not specified)
14 hex	<b>Inadmissible value</b> (change request with a value that is within the limits but which is illegal for other permanent reasons, i.e. a parameter with defined individual values)
15 hex	<b>Response too long</b> (the length of the actual response exceeds the maximum transfer length)
16 hex	<b>Illegal parameter address</b> (illegal or unsupported value for attribute, number of elements, parameter number, subindex or a combination of these)
17 hex	<b>Illegal format</b> (change request for an illegal or unsupported format)
18 hex	<b>Number of values not consistent</b> (number of values of the parameter data to not match the number of elements in the parameter address)
19 hex	<b>Drive object does not exist</b> (access to a drive object that does not exist)
20 hex	<b>Parameter text cannot be changed</b>
21 hex	<b>Service is not supported</b> (illegal or not support request ID)
6B hex	<b>A change request for a controller that has been enabled is not possible</b> (The drive rejects the change request because the motor is switched on. Please observe the "Can be changed" parameter attribute (U, T) in Section "Parameter list (Page 313)".)
6C hex	<b>Unknown unit</b>
77 hex	<b>Change request is not possible during download</b>
81 hex	<b>Change request is not possible during download</b>
82 hex	<b>Accepting the master control is inhibited</b>
83 hex	<b>Desired interconnection is not possible</b> (the connector output does not supply a float value although the connector input requires a float value)
84 hex	<b>Drive does not accept a change request</b> (drive is busy with internal calculations)

Error value 1	Meaning
85 hex	No access methods defined
87 hex	Know-how protection active, access locked
C8 hex	Change request below the currently valid limit (change request to a value that lies within the "absolute" limits, but is however below the currently valid lower limit)
C9 hex	Change request above the currently valid limit (example: a parameter value is too large for the drive power)
CC hex	Change request not permitted (change is not permitted as the access code is not available)

**Examples**

Via FC 16, with one request, up to 122 registers can be written to directly one after the other.

**Header**

In addition to the slave address, enter the transfer type, the start address and the number of the following registers in the header.

**User data**

You control the access in the user data via register 40601.

In register 40602, you define the acyclic access as well as the length of the request data.

Register 40603 contains the request reference, which is defined by the user, and the access type reading or writing.

From register 40603 and higher, the request aligns acyclic communication via data set 47.

Register 40604 contains the number of the drive object (for V90 always 2) and the number of parameters that are read out or written to.

Register 40605 contains the attribute (for V90 always 0x10). In the number of elements you specify how many indices are read.

**Example: p1215 and p1120 read acyclically**

The table below formats a request to read the parameter values of p1215 and p1120 from slave number 1.

	Byte	Description
<b>Header</b>		
01 h	0	Slave address
10 h	1	Function code (write multiple)
0258 h	2,3	Register start address
000A h	4,5	Number of registers to be read (40601 ... 40610)
14 h	6	Number of data bytes (10 registers, each 2 bytes = 20 bytes)

	Byte	Description
<b>User data</b>		
0001 h	7,8	40601: DS47 Control = 1 (activate request)
2F10 h	9,10	40602: Function 2F h (47), request length 16 bytes (10 h)
8001 h	11,12	40603: Request reference = 80 h, request identifier = 1 h
0202 h	13,14	40604: V90 = 2 h, number of parameters = 2
1001 h	15,16	40605: Attribute, number of elements of the first parameter
04BF h	17,18	
0000 h	19,20	40606: First parameter number = p1215
1001 h	21,22	40607: First parameter subindex = 0
0460 h	23,24	40608: Attribute, number of elements of the second parameter
0000 h	25,26	
		40609: Second parameter number = p1120
		40610: Second parameter subindex = 0

Write the PLC command from registers 40601 to 40610:

Address	Format	Current Value
1 H40601	Hexadecimal	16#0001
2 H40602	Hexadecimal	16#2F10
3 H40603	Hexadecimal	16#8001
4 H40604	Hexadecimal	16#0202
5 H40605	Hexadecimal	16#1001
6 H40606	Signed	+1215
7 H40607	Hexadecimal	16#0000
8 H40608	Hexadecimal	16#1001
9 H40609	Unsigned	1120
10 H40610	Hexadecimal	16#0000

The table below formats a response for successful read operation.

	Byte	Description
<b>Header</b>		
01 h	0	Slave address
03 h	1	Function code (read)
20 h	2	Number of following data bytes (20 h: 32 bytes $\hat{=}$ 16 registers)
<b>User data</b>		
0002 h	3,4	40601: DS47 Control = 2 (request was executed)
2F0E h	5,6	40602: Function code 2F h (47), response lengths 14 bytes (0e h)
8001 h	7,8	40603: Request reference mirrored = 80 h, response identifier = 1 (request parameter)
0202 h	9,10	40604: V90 = 2 h, number of parameters = 2
0301 h	11,12	40605: Format, number of elements of the first parameter
0001 h	13,14	40606: First parameter value = 1
0801 h	15,16	40607: Format, number of elements of the second parameter
4142 h	17,18	40608: Second parameter value = 12.15 (41426666 h)
6666 h	19,20	40609: Second parameter value

Write the PLC command from registers 40601 to 40609:

The table below formats a response for unsuccessful read operation (read request still not completed).

	Byte	Description
<b>Header</b>		
01 h	0	Slave address
03 h	1	Function code (read)
20 h	2	Number of following data bytes (20 h: 32 bytes $\hat{=}$ 16 registers)
<b>User data</b>		
0001 h	3,4	40601: Check value 1 = request is processed
2F00 h	5,6	40602: Function 2F h(47), response length 0 (fault)
0004 h	7,8	40603: Error code: 0004 Response Not Ready (response has still not been issued)

**Example: Set p1121 = 11.28 and p29130 = 2**

The table below formats a request to write the parameter values of p1121 and p29130 from slave number 1.

	Byte	Description
<b>Header</b>		
01 h	0	Slave address
10 h	1	Function code (write multiple)
0258 h	2,3	Register start address
000A h	4,5	Number of registers to be written to (40601 ... 40615)
1E h	6	Number of data bytes (15 registers, each 2 bytes = 30 bytes)



	Byte	Description
<b>User data</b>		
0001 h	7,8	40601: ds47=1 (activate request)
2F1A h	9,10	40602: Function 2F h (47), request length 16 bytes (10 h)
8002 h	11,12	40603: Request reference = 80 h, request identifier = 2 h (write)
0202 h	13,14	40604: V90 = 2 h, number of parameters = 2
1001 h	15,16	40605: Attribute, number of elements of the first parameter
0461 h	17,18	40606: First paramter number = p1121
0000 h	19,20	40607: First parameter subindex = 0
1001 h	21,22	40608: Attribute, number of elements of the second parameter
71CA h	23,24	40609: Second paramter number = p29130
0000 h	25,26	40610: Second parameter subindex = 0
0801 h	27,28	40611: Format, number of values of the first parameter
4134 h	29,30	40612: First parameter value 11.28 (41347AE1 h)
7AE1 h	31,32	40613: First parameter value
0301 h	33,34	40614: Format, number of values of the second parameter
0002 h	35,36	40615: Second parameter value 2

Write the PLC command from registers 40601 to 40615:

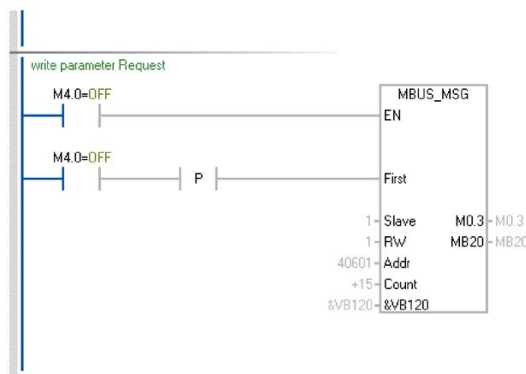

Address	Format	Current Value
1	reW40601	Hexadecimal 16#0001
2	reW40602	Hexadecimal 16#2F1A
3	reW40603	Hexadecimal 16#8002
4	reW40604	Hexadecimal 16#0202
5	reW40605	Hexadecimal 16#1001
6	reW40606	Unsigned 1121
7	reW40607	Hexadecimal 16#0000
8	reW40608	Hexadecimal 16#1001
9	reW40609	Unsigned 29130
10	reW40610	Hexadecimal 16#0000
11	reW40611	Hexadecimal 16#0801
12	reW40612	Hexadecimal 16#4134
13	reW40613	Hexadecimal 16#7AE1
14	reW40614	Hexadecimal 16#0301
15	reW40615	Hexadecimal 16#0002

The table below formats a response for successful write operation.

	Byte	Description
<b>Header</b>		
01 h	0	Slave address
03 h	1	Function code (read)
20 h	2	Number of following data bytes (20 h: 32 bytes $\triangleq$ 16 registers)
<b>User data</b>		
0002 h	3,4	40601: DS47 Control = 2 (request was executed)
2F04 h	5,6	40602: Function code 2F h (47), response length 4 bytes
8002 h	7,8	40603: Request reference mirrored = 80 h, response identifier = 2 (change parameter)
0202 h	9,10	40604: V90 = 2 h, number of parameters = 2

Write the PLC command from registers 40601 to 40604:

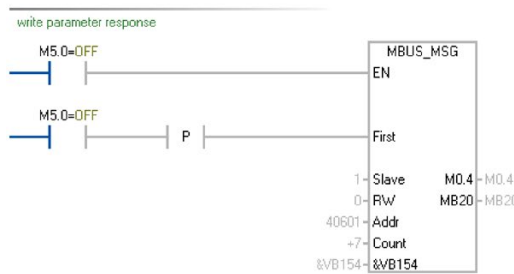

Address	Format	Current Value
16	Rpw40601	Hexadecimal 16#0002
17	Rpw40602	Hexadecimal 16#2F04
18	Rpw40603	Hexadecimal 16#8002
19	Rpw40604	Hexadecimal 16#0202
20	Rpw40605	Hexadecimal 16#0000
21	Rpw40606	Hexadecimal 16#0000
22	Rpw40607	Hexadecimal 16#0000

The table below formats a response for unsuccessful write operation (write request still not completed).

	Byte	Description
<b>Header</b>		
01 h	0	Slave address
03 h	1	Function code (read)
20 h	2	Number of following data bytes (20 h: 32 bytes $\hat{=}$ 16 registers)
<b>User data</b>		
0001 h	3,4	40601: DS47 Control = 1 (request is processed)
2F00 h	5,6	40602: Function 2F h(47), response length 0 (fault)
0004 h	7,8	40603: Error code: 0004 Response Not Ready (response has still not been issued)

## 7.8 Absolute position system

### 7.8.1 Overview

When the SINAMICS V90 servo drive uses a servo motor with an absolute encoder, the current absolute position can be detected and transmitted to the controller. With this function of the absolute position system, you can perform motion control task immediately after the servo system is powered on, which means you do not have to carry out referencing or zero position operation beforehand.

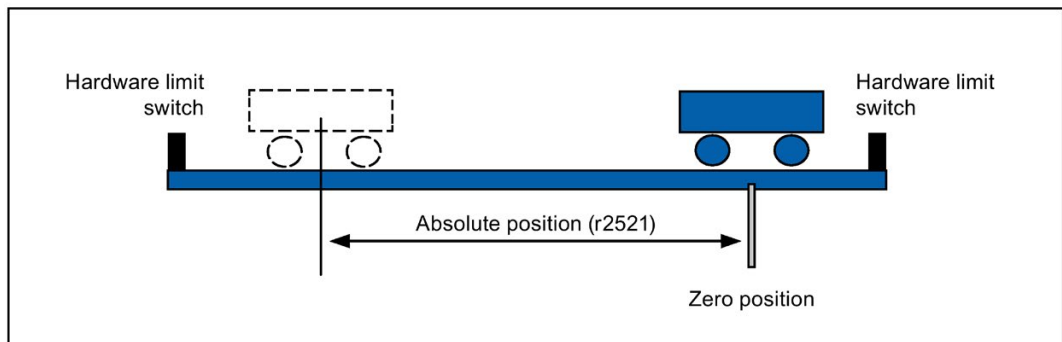

### Restrictions

The absolute position system **cannot** be configured under the following conditions:

- Internal position control (IPos)
- Speed control (S)
- Torque control (T)
- Control change mode
- Strokeless coordinate system, for example, rotary shaft, infinitely long positioning operation
- Change of electronic gear after referencing
- Use of alarm code output

### 7.8.2 Transmitting sequence for the absolute position data

The following table shows you the transmitting sequence for the absolute position data:

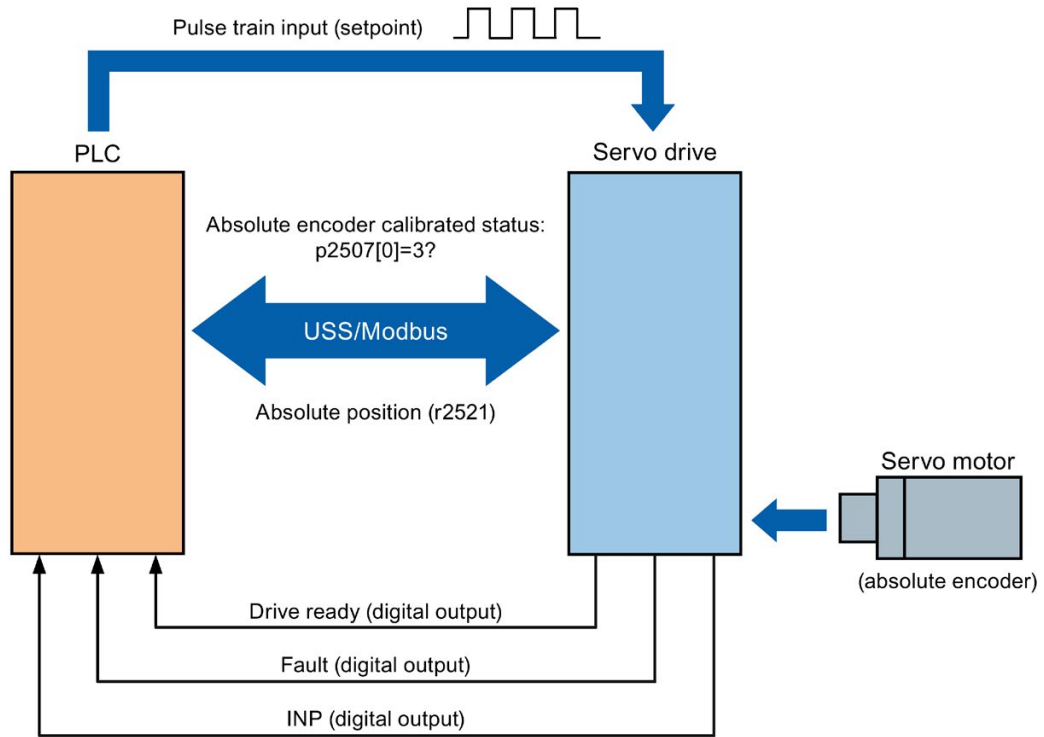

Main step	Sub step/comment
① Set PTI control mode.	Set p29003 = 0.
② Enable absolute position mode.	Set p29250 = 1.
③ Configure relative parameters.	1. Set PTI input parameters (p29010 to p29014). 2. Set electrical gear p29012 and p29013.
④ Referencing with the BOP or SINAMICS V-ASSISTANT. <b>NOTE:</b> You must perform the referencing operation under the following conditions: <ul style="list-style-type: none"> <li>• System setup is performed.</li> <li>• The servo drive has been changed.</li> <li>• The servo motor has been changed.</li> <li>• An alarm occurs.</li> </ul>	1. Run the servo motor for a proper distance. 2. Adjust the absolute encoder with the BOP menu function "ABS" or SINAMICS V-ASSISTANT.
⑤ Select a communication protocol with p29007.	Set value for p29007. <ul style="list-style-type: none"> <li>• 0: no protocol</li> <li>• 1: USS protocol</li> <li>• 2: Modbus protocol</li> </ul>

<b>Main step</b>	<b>Sub step/comment</b>
⑥ Configure the parameters for selected communication protocol.	<ol style="list-style-type: none"> <li>1. Set RS485 address (p29004).</li> <li>2. Set baud rate (p29009).</li> <li>3. Set the command and setpoint source if you use Modbus protocol (p29008).</li> </ol>
⑦ Save the parameters and restart the drive.	
⑧ Start transmitting.	
⑨ Transmit the calibration status of the absolute encoder to the PLC.	<ol style="list-style-type: none"> <li>1. Turn on the servo-on enable signal (SON).</li> <li>2. The PLC checks the standstill status and alarm status through the digital output of the servo drive.</li> <li>3. If there is no alarm and the motor is in standstill status, the PLC sends a data request to the servo drive through the RS485 cable.</li> <li>4. In response to the data request from PLC, the servo drive transmits calibration status (p2507[0]=3) of encoder to the PLC.</li> </ol>
⑩ Transmit the absolute position data to the PLC.	<ol style="list-style-type: none"> <li>1. If the absolute encoder is calibrated, and meanwhile, the servo drive is ready (the digital output RDY is logic 1) and in standstill status (the digital output signal INP is logic 1), the PLC sends a data request to the drive through the RS485 cable.</li> <li>2. In response to the data request from the PLC, the servo drive transmits the absolute position data (r2521) to the PLC.</li> </ol>

# Safety Integrated function

## 8.1 Standards and regulations

### 8.1.1 General information

#### 8.1.1.1 Aims

Manufacturers and operating companies of equipment, machines, and products are responsible for ensuring the required level of safety. This means that plants, machines, and other equipment must be designed to be as safe as possible in accordance with the current state of the art. To ensure this, companies describe in the various standards the current state of the art covering all aspects relevant to safety. When the relevant Standards are observed, this ensures that state-of-the-art technology has been utilized and, in turn, the erector/builder of a plant or a manufacturer of a machine or a piece of equipment has fulfilled his appropriate responsibility.

Safety systems are designed to minimize potential hazards for both people and the environment by means of suitable technical equipment, without restricting industrial production and the use of machines more than is necessary. The protection of man and environment must be assigned equal importance in all countries, which is it is important that rules and regulations that have been internationally harmonized are applied. This is also designed to avoid distortions in the competition due to different safety requirements in different countries.

There are different concepts and requirements in the various regions and countries of the world when it comes to ensuring the appropriate degree of safety. The legislation and the requirements of how and when proof is to be given and whether there is an adequate level of safety are just as different as the assignment of responsibilities.

The most important thing for manufacturers of machines and companies that set up plants and systems is that the legislation and regulations in the country where the machine or plant is being operated apply. For example, the control system for a machine that is to be used in the US must fulfill local US requirements even if the machine manufacturer (OEM) is based in the European Economic Area (EEA).

### 8.1.1.2 Functional safety

Safety, from the perspective of the object to be protected, cannot be split-up. The causes of hazards and, in turn, the technical measures to avoid them can vary significantly. This is why a differentiation is made between different types of safety (e.g. by specifying the cause of possible hazards). "Functional safety" is involved if safety depends on the correct function. To ensure the functional safety of a machine or plant, the safety-related parts of the protection and control devices must function correctly. In addition, the systems must behave in such a way that either the plant remains in a safe state or it is brought into a safe state if a fault occurs. In this case, it is necessary to use specially qualified technology that fulfills the requirements described in the associated Standards. The requirements to achieve functional safety are based on the following basic goals:

- Avoiding systematic faults
- Controlling systematic faults
- Controlling random faults or failures

Benchmarks for establishing whether or not a sufficient level of functional safety has been achieved include the probability of hazardous failures, the fault tolerance, and the quality that is to be ensured by minimizing systematic faults. This is expressed in the Standards using different terms. In IEC/EN 61508, IEC/EN 62061 "Safety Integrity Level" (SIL) and EN ISO 13849-1 "Categories" and "Performance Level" (PL).

## 8.1.2 Safety of machinery in Europe

The EU Directives that apply to the implementation of products are based on Article 95 of the EU contract, which regulates the free exchange of goods. These are based on a new global concept ("new approach", "global approach"):

- EU Directives only specify general safety goals and define basic safety requirements.
- Technical details can be defined by means of standards by Standards Associations that have the appropriate mandate from the commission of the European Parliament and Council (CEN, CENELEC). These standards are harmonized in line with a specific directive and listed in the official journal of the commission of the European Parliament and Council. Legislation does not specify that certain standards have to be observed. When the harmonized Standards are observed, it can be assumed that the safety requirements and specifications of the Directives involved have been fulfilled.
- EU Directives specify that the Member States must mutually recognize domestic regulations.

The EU Directives are equal. This means that if several Directives apply for a specific piece of equipment or device, the requirements of all of the relevant Directives apply (e.g. for a machine with electrical equipment, the Machinery Directive and the Low-Voltage Directive apply).

### 8.1.2.1 Machinery Directive

The basic safety and health requirements specified in Annex I of the Directive must be fulfilled for the safety of machines.

The protective goals must be implemented responsibly to ensure compliance with the Directive.

Manufacturers of a machine must verify that their machine complies with the basic requirements. This verification is facilitated by means of harmonized standards.

### **8.1.2.2 Harmonized European Standards**

The two Standards Organizations CEN (Comité Européen de Normalisation) and CENELEC (Comité Européen de Normalisation Électrotechnique), mandated by the EU Commission, drew-up harmonized European standards in order to precisely specify the requirements of the EC directives for a specific product. These standards (EN standards) are published in the official journal of the commission of the European Parliament and Council and must be included without revision in domestic standards. They are designed to fulfill basic health and safety requirements as well as the protective goals specified in Annex I of the Machinery Directive.

When the harmonized standards are observed, it is "automatically assumed" that the Directive is fulfilled. As such, manufacturers can assume that they have observed the safety aspects of the Directive under the assumption that these are also covered in this standard. However, not every European Standard is harmonized in this sense. Key here is the listing in the official journal of the commission of the European Parliament and Council.

The European Safety of Machines standard is hierarchically structured. It is divided into:

- A standards (basic standards)
- B standards (group standards)
- C standards (product standards)

#### **Type A standards/basic standards**

A standards include basic terminology and definitions relating to all types of machine. This includes EN ISO 12100-1 (previously EN 292-1) "Safety of Machines, Basic Terminology, General Design Principles".

A standards are aimed primarily at the bodies responsible for setting the B and C standards. The measures specified here for minimizing risk, however, may also be useful for manufacturers if no applicable C standards have been defined.

#### **Type B standards/group standards**

B standards cover all safety-related standards for various different machine types. B standards are aimed primarily at the bodies responsible for setting C standards. They can also be useful for manufacturers during the machine design and construction phases, however, if no applicable C standards have been defined.

A further sub-division has been made for B standards:

- Type B1 standards for higher-level safety aspects (e.g. ergonomic principles, safety clearances from sources of danger, minimum clearances to prevent parts of the body from being crushed).
- Type B2 standards for protective safety devices are defined for different machine types (e.g. EMERGENCY STOP devices, two-hand operating circuits, interlocking elements, contactless protective devices, safety-related parts of controls).



### Type C standards/product standards

C standards are product-specific standards (e.g. for machine tools, woodworking machines, elevators, packaging machines, printing machines etc.). Product standards cover machine-specific requirements. The requirements can, under certain circumstances, deviate from the basic and group standards. Type C/product standards have the highest priority for machine manufacturers who can assume that it fulfills the basic requirements of Annex I of the Machinery Directive (automatic presumption of compliance). If no product standard has been defined for a particular machine, type B standards can be applied when the machine is constructed.

A complete list of the standards specified and the mandated draft standards are available on the Internet at the following address:

<http://www.newapproach.org/>

Recommendation: Due to the rapid pace of technical development and the associated changes in machine concepts, the standards (and C standards in particular) should be checked to ensure that they are up to date. Please note that the application of a particular standard may not be mandatory provided that all the safety requirements of the applicable EU directives are fulfilled.

### 8.1.2.3 Standards for implementing safety-related controllers

If the functional safety of a machine depends on various control functions, the controller must be implemented in such a way that the probability of the safety functions failing is sufficiently minimized. EN ISO 13849-1 and EN IEC61508 define principles for implementing safety-related machine controllers which, when properly applied, ensure that all the safety requirements of the EC Machinery Directive are fulfilled. These standards ensure that the relevant safety requirements of the Machinery Directive are fulfilled.

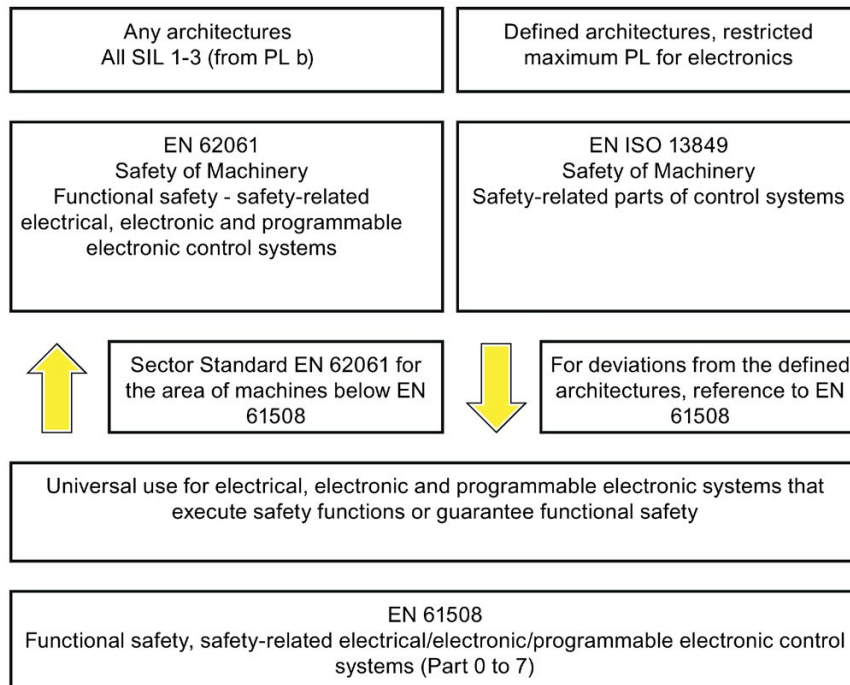

8.1 Standards and regulations

The application areas of EN ISO 13849-1, EN 62061, and EN 61508 are very similar. To help users make an appropriate decision, the IEC and ISO associations have specified the application areas of both standards in a joint table in the introduction to the standards. EN ISO 13849-1 or EN 62061 should be applied depending on the technology (mechanics, hydraulics, pneumatics, electrics, electronics and programmable electronics), risk classification and architecture.

Type	Systems for executing safety-related control functions	EN ISO 13849-1	EN 62061
A	Non-electrical (e.g. hydraulic, pneumatic)	X	Not covered
B	Electromechanical (e.g. relay and/or basic electronics)	Restricted to the designated architectures (see comment 1) and max. up to PL = e	All architectures and max. up to SIL 3
C	Complex electronics (e.g. programmable electronics)	Restricted to the designated architectures (see comment 1) and max. up to PL = d	All architectures and max. up to SIL 3
D	A standards combined with B standards	Restricted to the designated architectures (see comment 1) and max. up to PL = e	X See comment 3
E	C standards combined with B standards	Restricted to the designated architectures (see comment 1) and max. up to PL = d	All architectures and max. up to SIL 3
F	C standards combined with A standards or C standards combined with A standards and B standards	X See comment 2	X See comment 3

"X" indicates that the point is covered by this standard.

Comment 1:  
Designated architectures are described in Annex B of EN ISO 13849-1 and provide a simplified basis for the quantification.

Comment 2:  
For complex electronics: Using designated architectures in compliance with EN ISO 13849-1 up to PL = d or every architecture in compliance with EN 62061.

Comment 3:  
For non-electrical systems: Use components that comply with EN ISO 13849-1 as sub-systems.

8.1.2.4 DIN EN ISO 13849-1

A qualitative analysis according to DIN ISO EN 13849-1 is not sufficient for modern control systems due to their technology. Among other things, DIN EN ISO 13849-1 does not take into account time behavior (e.g. test interval and/or cyclic test, lifetime). This results in the probabilistic approach in DIN EN ISO 13849-1 (probability of failure per unit time). DIN EN ISO 13849-1 takes into account complete safety functions and all the devices required to execute these. With DIN EN ISO 13849-1, safety functions are investigated from the qualitative perspective as well as the quantitative perspective. Performance levels (PL), which are based on the categories, are used. The following safety-related characteristic quantities are required for devices/equipment:

- Category (structural requirement)
- PL: Performance level

- MTTF<sub>d</sub>: Mean time to dangerous failure
- DC: Diagnostic coverage
- CCF: Common cause failure

The standard describes how the performance level (PL) is calculated for safety-related components of the controller on the basis of designated architectures. In the event of any deviations from this, EN ISO 13849-1 refers to EN 61508.

When combining several safety-related parts to form a complete system, the standard explains how to determine the resulting PL.

---

**Note**

**DIN EN ISO 13849-1 and machinery directive**

Since May 2007, DIN EN ISO 13849-1 has been harmonized as part of the Machinery Directive.

---

### 8.1.2.5 EN 62061

EN 62061 (identical to IEC 62061) is a sector-specific standard subordinate to IEC/EN 61508. It describes the implementation of safety-related electrical machine control systems and looks at the complete life cycle, from the conceptual phase to decommissioning. The standard is based on the quantitative and qualitative analyses of safety functions, whereby it systematically applies a top-down approach to implementing complex control systems (known as "functional decomposition"). The safety functions derived from the risk analysis are sub-divided into sub-safety functions, which are then assigned to real devices, sub-systems, and sub-system elements. Both the hardware and software are covered. EN 62061 also describes the requirements placed on implementing application programs.

A safety-related control system comprises different sub-systems. From a safety perspective, the sub-systems are described in terms of the SIL claim limit and PFHD characteristic quantities.

Programmable electronic devices (e.g. PLCs or variable-speed drives) must fulfill EN 61508. They can then be integrated in the controller as sub-systems. The following safety-related characteristic quantities must be specified by the manufacturers of these devices.

Safety-related characteristic quantities for subsystems:

- SIL CL: SIL claim limit
- PFHD: Probability of dangerous failures per hour
- T1: Lifetime

Simple sub-systems (e.g. sensors and actuators) in electromechanical components can, in turn, comprise sub-system elements (devices) interconnected in different ways with the characteristic quantities required for determining the relevant PFHD value of the sub-system.

Safety-related characteristic quantities for subsystem elements (devices):

- $\lambda$ : Failure rate
- B10 value: For elements that are subject to wear
- T1: Lifetime

For electromechanical devices, a manufacturer specifies a failure rate  $\lambda$  with reference to the number of operating cycles. The failure rate per unit time and the lifetime must be determined using the switching frequency for the particular application.

Parameters for the sub-system, which comprises sub-system elements, that must be defined during the design phase:

- T2: Diagnostic test interval
- $\beta$ : Susceptibility to common cause failure
- DC: Diagnostic coverage

The PFHD value of the safety-related controller is determined by adding the individual PFHD values for subsystems.

The user has the following options when setting up a safety-related controller:

- Use devices and sub-systems that already comply with EN ISO 13849-1, IEC/EN 61508, or IEC/EN 62061. The standard provides information specifying how qualified devices can be integrated when safety functions are implemented.
- Develop own subsystems:
  - Programmable, electronic systems and complex systems: Application of EN 61508 or EN 61800-5-2.
  - Simple devices and subsystems: Application of EN 62061.

EN 62061 does not include information about non-electric systems. The standard provides detailed information on implementing safety-related electrical, electronic, and programmable electronic control systems. EN ISO 13849-1 must be applied for non-electric systems.

---

**Note**

**Function examples**

Details of simple sub-systems that have been implemented and integrated are now available as "functional examples".

---

**Note**

**EN 62061 and machinery directive**

IEC 62061 has been ratified as EN 62061 in Europe and harmonized as part of the Machinery Directive.

---

### 8.1.2.6 Series of standards EN 61508 (VDE 0803)

This series of standards describes the current state of the art.

EN 61508 is not harmonized in line with any EU directives, which means that an automatic presumption of conformity for fulfilling the protective requirements of a directive is not implied. The manufacturer of a safety-related product, however, can also use EN 61508 to fulfill basic requirements of European directives in accordance with the latest conceptual design, for example, in the following cases:

- If no harmonized standard exists for the application in question. In this case, the manufacturer can use EN 61508, although no presumption of conformity exists here.
- A harmonized European standard (e.g. EN 62061, EN ISO 13849, EN 60204-1) references EN 61508. This ensures that the appropriate requirements of the directives are fulfilled ("standard that is also applicable"). When manufacturers apply EN 61508 properly and responsibly in accordance with this reference, they can use the presumption of conformity of the referencing standard.

EN 61508 covers all the aspects that must be taken into account when E/E/PES systems (electrical, electronic, and programmable electronic System) are used in order to execute safety functions and/or to ensure the appropriate level of functional safety. Other hazards (e.g. electric shock) are, as in EN ISO 13849, not part of the standard.

EN 61508 has recently been declared the "International Basic Safety Publication", which makes it a framework for other, sector-specific standards (e.g. EN 62061). As a result, this standard is now accepted worldwide, particularly in North America and in the automotive industry. Today, many regulatory bodies already stipulate it (e.g. as a basis for NRTL listing).

Another recent development with respect to EN 61508 is its system approach, which extends the technical requirements to include the entire safety installation from the sensor to the actuator, the quantification of the probability of hazardous failure due to random hardware failures, and the creation of documentation covering all phases of the safety-related lifecycle of the E/E/PES.

### 8.1.2.7 Risk analysis/assessment

Risks are intrinsic in machines due to their design and functionality. For this reason, the Machinery Directive requires that a risk assessment be performed for each machine and, if necessary, the level of risk reduced until the residual risk is less than the tolerable risk. To assess these risks, the following standards must be applied:

EN ISO 12100-1 "Safety of Machinery - basic terminology, general principles for design"

EN ISO 13849-1 "Safety-related parts of control systems"

EN ISO 12100-1 focuses on the risks to be analyzed and the design principles for minimizing risk.

The risk assessment is a procedure that allows hazards resulting from machines to be systematically investigated. Where necessary, the risk assessment is followed by a risk reduction procedure. When the procedure is repeated, this is known as an iterative process. This can help eliminate hazards (as far as this is possible) and can act as a basis for implementing suitable protective measures.

The risk assessment involves the following:

- Risk analysis
  - Determines the limits of the machine (EN ISO 12100-1)
  - Identification of the hazards (EN ISO 12100-114)
  - Estimating the level of risk (EN 1050 Paragraph 7)
- Risk evaluation

As part of the iterative process to achieve the required level of safety, a risk assessment is carried out after the risk estimation. A decision must be made here as to whether the

residual risk needs to be reduced. If the risk is to be further reduced, suitable protective measures must be selected and applied. The risk assessment must then be repeated.

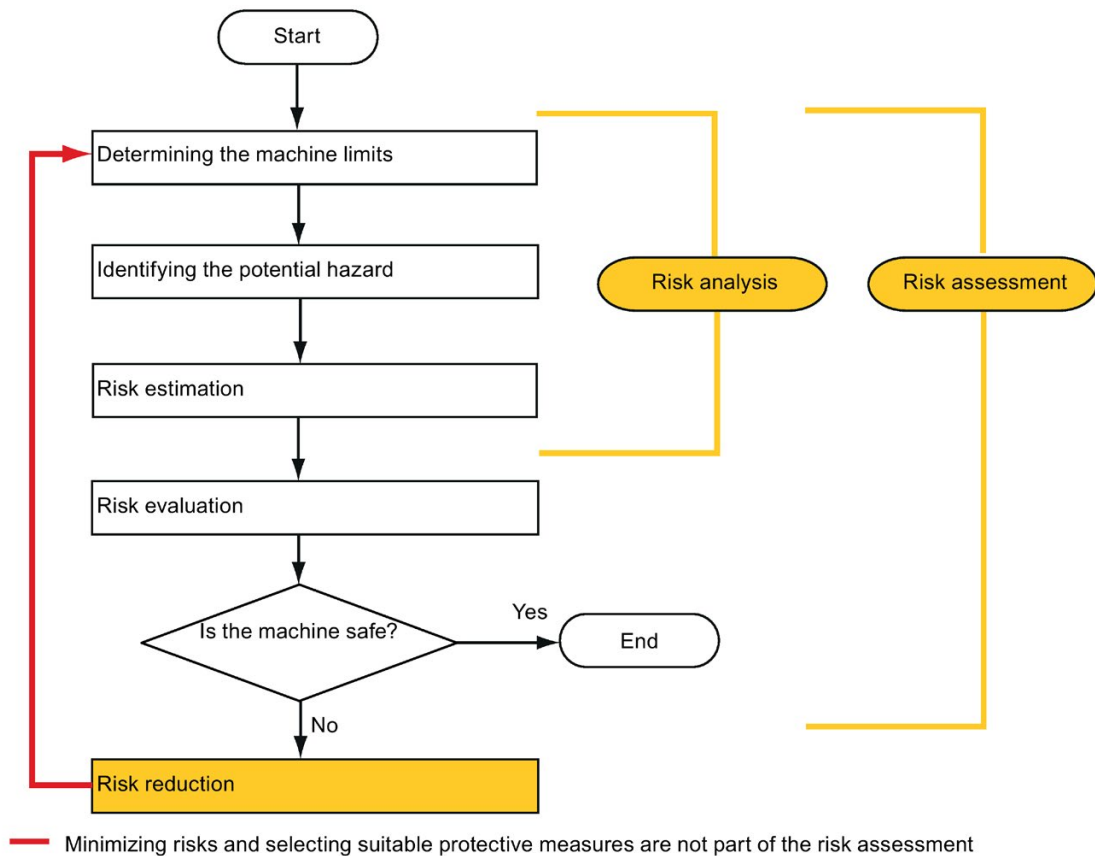

Risks must be reduced by designing and implementing the machine accordingly (e.g. by means of controllers or protective measures suitable for the safety-related functions).

If the protective measures involve the use of interlocking or control functions, these must be designed according to EN ISO 13849-1. For electrical and electronic controllers, EN 62061 can be used as an alternative to EN ISO 13849-1. Electronic controllers and bus systems must also comply with IEC/EN 61508.

### 8.1.2.8 Risk reduction

Risk reduction measures for a machine can be implemented by means of safety-related control functions in addition to structural measures. To implement these control functions, special requirements must be taken into account, graded according to the magnitude of the risk. These are described in EN ISO 13849-1 or, in the case of electrical controllers (particularly programmable electronics), in EN 61508 or EN 62061. The requirements regarding safety-related controller components are graded according to the magnitude of the risk and the level to which the risk needs to be reduced.

**EN ISO 13849-1** defines a risk flow chart that instead of categories results in hierarchically graduated Performance Levels (PL).

**IEC/EN 62061** uses "Safety Integrity Level" (SIL) for classification purposes. This is a quantified measure of the safety-related performance of a controller. The required SIL is also determined in accordance with the risk assessment principle according to ISO 12100 (EN 1050). Annex A of the standard describes a method for determining the required Safety Integrity Level (SIL).

Regardless of which standard is applied, steps must be taken to ensure that all the machine controller components required for executing the safety-related functions fulfill these requirements.

### **8.1.2.9 Residual risk**

In today's technologically advanced world, the concept of safety is relative. The ability to ensure safety to the extent that risk is ruled out in all circumstances – "zero-risk guarantee" – is practically impossible. The residual risk is the risk that remains once all the relevant protective measures have been implemented in accordance with the latest state of the art.

Residual risks must be clearly referred to in the machine/plant documentation (user information according to EN ISO 12100-2).

## **8.1.3 Machine safety in the USA**

A key difference between the USA and Europe in the legal requirements regarding safety at work is that, in the USA, no legislation exists regarding machinery safety that is applicable in all of the states and that defines the responsibility of the manufacturer/supplier. A general requirement exists stating that employers must ensure a safe workplace.

### **8.1.3.1 Minimum requirements of the OSHA**

The Occupational Safety and Health Act (OSHA) from 1970 regulates the requirement that employers must offer a safe place of work. The core requirements of OSHA are specified in Section 5 "Duties".

The requirements of the OSH Act are managed by the "Occupational Safety and Health Administration" (also known as OSHA). OSHA employs regional inspectors who check whether or not workplaces comply with the applicable regulations.

The OSHA regulations are described in OSHA 29 CFR 1910.xxx ("OSHA Regulations (29 CFR) PART 1910 Occupational Safety and Health"). (CFR: Code of Federal Regulations.)

<http://www.osha.gov>

The application of standards is regulated in 29 CFR 1910.5 "Applicability of standards". The concept is similar to that used in Europe. Product-specific standards have priority over general standards insofar as they cover the relevant aspects. Once the standards are fulfilled, employers can assume that they have fulfilled the core requirements of the OSH Act with respect to the aspects covered by the standards.

In conjunction with certain applications, OSHA requires that all electrical equipment and devices that are used to protect workers be authorized by an OSHA-certified, "Nationally Recognized Testing Laboratory" (NRTL) for the specific application.

## 8.1 Standards and regulations

In addition to the OSHA regulations, the current standards defined by organizations such as NFPA and ANSI must be carefully observed and the extensive product liability legislation that exists in the US taken into account. Due to the product liability legislation, it is in the interests of manufacturing and operating companies that they carefully maintain the applicable regulations and are "forced" to fulfill the requirement to use state-of-the-art technology.

Third-party insurance companies generally demand that their customers fulfill the applicable standards of the standards organizations. Self-insured companies are not initially subject to this requirement but, in the event of an accident, they must provide verification that they have applied generally-recognized safety principles.

### 8.1.3.2 NRTL listing

To protect employees, all electrical equipment used in the USA must be certified for the planned application by a "Nationally Recognized Testing Laboratory" (NRTL) certified by the OSHA. NRTLs are authorized to certify equipment and material by means of listing, labeling, or similar. Domestic standards (e.g. NFPA 79) and international standards (e.g. IEC/EN 61508 for E/E/PES systems) are the basis for testing.

### 8.1.3.3 NFPA 79

Standard NFPA 79 (Electrical Standard for Industrial Machinery) applies to electrical equipment on industrial machines with rated voltages of less than 600 V. A group of machines that operate together in a coordinated fashion is also considered to be one machine.

For programmable electronics and communication buses, NFPA 79 states as a basic requirement that these must be listed if they are to be used to implement and execute safety-related functions. If this requirement is fulfilled, then electronic controls and communication buses can also be used for Emergency Stop functions, Stop Categories 0 and 1 (refer to NFPA 79 9.2.5.4.1.4). Like EN 60204-1, NFPA 79 no longer specifies that the electrical energy must be disconnected by electromechanical means for emergency stop functions.

The core requirements regarding programmable electronics and communication buses are: system requirements (see NFPA 79 9.4.3)

1. Control systems that contain software-based controllers must:

- In the event of a single fault
  - cause the system to switch to a safe shutdown mode
  - prevent the system from restarting until the fault has been rectified
  - prevent an unexpected restart
- Offer the same level of protection as hard-wired controllers
- Be implemented in accordance with a recognized standard that defines the requirements for such systems.

2. IEC 61508, IEC 62061, ISO 13849-1, ISO 13849 2 and IEC 61800-5-2 are specified as suitable standards in a note.



**Underwriter Laboratories Inc. (UL)** has defined a special category for "Programmable Safety Controllers" for implementing this requirement (code NRGF). This category covers control devices that contain software and are designed for use in safety-related functions.

A precise description of the category and a list of devices that fulfill this requirement can be found on the Internet at the following address:

<http://www.ul.com> → certifications directory → UL Category code/ Guide information → search for category "NRGF"

**TUV Rheinland of North America, Inc.** is also an NRTL for these applications.

### 8.1.3.4 ANSI B11

ANSI B11 standards are joint standards developed by associations such as the Association for Manufacturing Technology (AMT) and the Robotic Industries Association (RIA).

The hazards of a machine are evaluated by means of a risk analysis/assessment. The risk analysis is an important requirement in accordance with NFPA 79, ANSI/RIA 15.06, ANSI B11.TR-3 and SEMI S10 (semiconductors). The documented findings of a risk analysis can be used to select a suitable safety system based on the safety class of the application in question.

The situation in Japan is different from that in Europe and the US. Legislation such as that prescribed in Europe does not exist. Similarly, product liability does not play such an important role as it does in the US.

Instead of legal requirements to apply standards have been defined, an administrative recommendation to apply JIS (Japanese Industrial Standard) is in place: Japan bases its approach on the European concept and uses basic standards as national standards (see table).

#### Japanese standards

ISO/IEC number	JIS number	Comment
ISO12100-1	JIS B 9700-1	Earlier designation TR B 0008
ISO12100-2	JIS B 9700-2	Earlier designation TR B 0009
ISO14121- 1 / EN1050	JIS B 9702	
ISO13849- 1	JIS B 9705-1	
ISO13849- 2	JIS B 9705-1	
IEC 60204-1	JIS B 9960-1	Without annex F or route map of the European foreword
IEC 61508-0 to -7	JIS C 0508	
IEC 62061		JIS number not yet assigned

In addition to the requirements of the guidelines and standards, company-specific requirements must be taken into account. Large corporations in particular (e.g. automobile manufacturers) make stringent demands regarding automation components, which are often listed in their own equipment specifications.

Safety-related issues (e.g. operating modes, operator actions with access to hazardous areas, EMERGENCY STOP concepts, etc.) should be clarified with customers early on so that they can be integrated in the risk assessment/risk reduction process.

### 8.1.4 Machine safety in Japan

The situation in Japan is different from that in Europe and the US. Legislation such as that prescribed in Europe does not exist. Similarly, product liability does not play such an important role as it does in the US.

Instead of legal requirements to apply standards have been defined, an administrative recommendation to apply JIS (Japanese Industrial Standard) is in place: Japan bases its approach on the European concept and uses basic standards as national standards (see table).

#### Japanese standards

ISO/IEC number	JIS number	Comment
ISO12100-1	JIS B 9700-1	Earlier designation TR B 0008
ISO12100-2	JIS B 9700-2	Earlier designation TR B 0009
ISO14121- 1 / EN1050	JIS B 9702	
ISO13849-1	JIS B 9705-1	
ISO13849-2	JIS B 9705-1	
IEC 60204-1	JIS B 9960-1	Without annex F or route map of the European foreword
IEC 61508-0 to -7	JIS C 0508	
IEC 62061		JIS number not yet assigned

### 8.1.5 Equipment regulations

In addition to the requirements of the guidelines and standards, company-specific requirements must be taken into account. Large corporations in particular (e.g. automobile manufacturers) make stringent demands regarding automation components, which are often listed in their own equipment specifications.

Safety-related issues (e.g. operating modes, operator actions with access to hazardous areas, EMERGENCY STOP concepts, etc.) should be clarified with customers early on so that they can be integrated in the risk assessment/risk reduction process.

## 8.2 General information about SINAMICS Safety Integrated

### Safety Integrated function - STO

The Safe Torque Off (STO) is a safety function that prevents the drive from restarting unexpectedly, in accordance with EN 60204-1:2006 Section 5.4.

The STO function is in conformance with the IEC 61508, SIL2 standard, in the operating mode with a high demand, Category 3 and Performance Level d (PL d) acc. to ISO 13849-1:2015, as well as IEC 61800-5-2.

## Controlling the STO Function

The STO function can be controlled via terminals. For the details about STO wiring, refer to the chapter "24 V power supply/STO (Page 139)".

## 8.3 System features

### 8.3.1 STO functional safety data

The STO functional safety data of SINAMICS V90 is as follows:

Applied standards	IEC 61508, IEC 62061, ISO 13849-1
Type	A
Safety Integrity Level (SIL)	2
Hardware Fault Tolerance (HFT)	1
Probability of Failure per Hour (PFH)	$5 \times 10^{-8}$ per hour

### 8.3.2 Certification

The safety function of the SINAMICS V90 drive system meets the following requirements:

- Category 3 according to ISO 13849-1:2015
- Performance Level (PL) d to ISO 13849-1:2015
- Safety integrity level 2 (SIL 2) to IEC 61508

In addition, the safety function of SINAMICS V90 has been certified by independent institutes. An up-to-date list of certified components is available on request from your local Siemens office.

### 8.3.3 Safety instructions

---

#### Note

Residual risks not specified in this section are included in the chapter "Fundamental safety instructions (Page 11)".

---

 **DANGER**

**Death or serious injury resulting from failure to observe the Safety Integrated instructions**

Safety Integrated can be used to minimize the level of risk associated with machines and plants. Failure to observe the Safety Integrated instructions. Machines and plants can only be operated safely in conjunction with Safety Integrated when the machine manufacturer is familiar with and observes every aspect of this technical user documentation, including the documented general conditions, safety information, and residual risks.

- Precisely knows and observes this technical user documentation - including the documented limitations, safety information and residual risks;
- Carefully constructs and configures the machine/plant. A careful and thorough acceptance test must then be performed by qualified personnel and the results documented.
- Implements and validates all the measures required in accordance with the machine/plant risk analysis by means of the programmed and configured Safety Integrated functions or by other means.
- The use of Safety Integrated does not replace the machine/plant risk assessment carried out by the machine manufacturer as required by the EC machinery directive.
- In addition to using Safety Integrated functions, further risk reduction measures must be implemented.

 **WARNING**

**Failure to activate the Safety Integrated function due to system not startup**

The Safety Integrated functions cannot be activated until the system has been completely powered up. System startup is a critical operating state with increased risk. To start up the system, you need to make sure that the following requirements are fulfilled.

- No personnel is present in the immediate danger zone in this phase.
- The drives of vertical axes must be in torque state.
- A complete forced dormant error detection cycle is required after power on.

 **WARNING**

**Personal injury or device damage due to improper operations of the Emergency Stop function**

There is a personal injury or device damage if you use the Emergency Stop function improperly. According to the standard EN 60204-1:2006, Emergency Stop function must bring the machine to a standstill in accordance with STO.

- Make sure that, if you use the Emergency Stop function to shut down the machine, the machine is not allowed to restart automatically after EMERGENCY STOP.
- When the safety function is deactivated, an automatic restart is permitted under certain circumstances depending on the risk analysis (except when Emergency Stop is reset). For example, an automatic start is permitted when a protective door is closed.

**! WARNING****Personal injury or device damage due to improper operations after the hardware and/or software components change**

After hardware and/or software components have been modified or replaced, all protective equipment must be closed prior to system startup and drive activation; otherwise, personal injury or device damage occur.

- No personnel is present within the danger zone.
- Before allowing anybody to re-enter the danger zone, you should test steady control response by briefly moving the drives in forward and reverse direction (+/-).
- To use Safety Integrated functions, you need to make sure that the system has completely powered up.

### 8.3.4 Probability of failure of the safety function

#### Probability of failure per hour (PFH)

The probability of the failure of safety functions must be specified in the form of a PFH value in accordance with IEC 61508, IEC 62061, and ISO 13849-1:2015. The PFH value of a safety function depends on the safety concept of the drive unit and its hardware configuration, as well as on the PFH values of other components used for this safety function.

Corresponding PFH values are provided for the SINAMICS V90 drive system, depending on the hardware configuration (number of drives, control type, number of encoders used). The various integrated safety functions are not differentiated.

The PFH value of SINAMICS V90 drive system is  $5 \times 10^{-8}$  per hour.

#### Hardware fault tolerance (HFT)

The HFT value of SINAMICS V90 drive system is one. It means that the system can handle one fault without brake down. SINAMICS V90 STO function is a subsystem from type A, and only the discrete components are involved in the STO function.

### 8.3.5 Response time

Response time means the time from the control via terminals until the response actually occurs. For 200 V variant servo drives, the STO response time in the worst case is 15 ms. For 400 V variant servo drives, the STO response time in the worst case is 5 ms. The response time of fault reaction functions is 2 s.

### 8.3.6 Residual risk

The fault analysis enables the machine manufacturer to determine the residual risk at this machine with regard to the drive unit. The following residual risks are known:

 <b>WARNING</b>
<b>Personal injury or device damage due to the intrinsic potential of hardware faults</b>
Due to the intrinsic potential of hardware faults, electrical systems are subject to additional residual risk, which can be expressed by means of the PFH value.
<ul style="list-style-type: none"><li>• Take into account these residual risks when designing your machine and where necessary apply suitable countermeasures.</li></ul>

 <b>WARNING</b>
<b>Personal injury or device damage resulting from the simultaneous failure of two power transistors in the inverter</b>
Simultaneous failure of two power transistors (one in the upper and the other offset in the lower inverter bridge) in the drive may cause brief movement of the drive which can result in a personal injury or device damage. The movement depends on the number of poles of the motor. For a synchronous rotary motor, the maximum movement is 180 °/No. of pole pairs
<ul style="list-style-type: none"><li>• Take suitable measures to prevent unexpected drive movement, for example, by using a brake equipped with safety monitoring.</li></ul>

## 8.4 Safety Integrated basic functions

### 8.4.1 Safe Torque Off (STO)

In conjunction with a machine function or in the event of a fault, the "Safe Torque Off" (STO) function is used to safely disconnect and de-energize the torque-generating energy feed to the motor.

When the function is selected, the drive unit is in a "safe status". The switching on inhibited function prevents the drive unit from being restarted.

The two-channel pulse suppression function integrated in the Motor Modules/power units is a basis for this function.

#### Functional features of "Safe Torque Off"

- This function is integrated in the drive; this means that a higher-level controller is not required.
- The function is drive-specific, i.e. it is available for each drive and must be individually commissioned.

- When the "Safe Torque Off" function is selected, the following applies:
  - The motor cannot be started accidentally.
  - The pulse suppression safely disconnects the torque-generating energy feed to the motor.
  - The power unit and motor are not electrically isolated.
- By selecting/deselecting STO, the safety messages are automatically withdrawn.

The STO function can be used wherever the drive naturally reaches a standstill due to load torque or friction in a sufficiently short time or when "coasting down" of the drive will not have any relevance for safety.

 <b>WARNING</b>
<b>Personal injury or device damage resulting from the unexpected movement of the motor after the energy feed is disconnected</b>
The motor may have an undesirably move once the energy feed has been disconnected. This may lead to a personal injury or device damage.
<ul style="list-style-type: none"><li>• Take appropriate measures to ensure that the motor does not undesirably move in this case, e.g. against coasting down.</li></ul>

 <b>CAUTION</b>
<b>Personal injury or device damage resulting from the simultaneous failure of two power transistors in the inverter</b>
If two power transistors (one in the upper and one in the lower bridge) simultaneously fail in the drive, this can cause brief momentary movement. For a synchronous rotary motors, the maximum movement is 180 °/No. of pole pairs. For a synchronous liner motor, the maximum movement is the pole width.
<ul style="list-style-type: none"><li>• Take suitable measures to prevent unexpected drive movement, for example, by using a brake equipped with safety monitoring.</li></ul>

---

#### **Note**

##### **Closing delay of the holding brake**

The closing signal (low level) of the holding brake is output 30 ms after the STO is triggered.

---

##### **Preconditions for using the STO function**

When use the STO function, the following preconditions must be fulfilled:

- The high level duration of the input pulse is larger than 500 ms.

---

#### **Note**

If the input signal contains pluses whose high level duration are less than 500 ms, you need to decrease the sensitivity of the STO sensor or filter the input pulses by a PLC program or by a physical filter.

---

- Each monitoring channel (STO1 and STO2) triggers safe pulse suppression with its switch off signal path.
- If a motor holding brake is connected and configured, the connected brake is not safe because there is no safety function for brake, such as safe brake.

**Behaviors of the STO function**

Terminal		State	Action
STO1	STO2		
High level	High level	Safe	The servo motor can normally run when you power on the servo drive.
Low level	Low level	Safe	The servo drive starts up normally but the servo motor cannot run.
High level	Low level	Unsafe	Fault F1611 occurs and servo motor coasts down (OFF2).
Low level	High level	Unsafe	Fault F1611 occurs and servo motor coasts down (OFF2).

**Selecting/deselecting "Safe Torque Off"**

The following is executed when "Safe Torque Off" is selected:

- Each monitoring channel triggers safe pulse suppression via its switch-off signal path.
- A motor holding brake is closed (if connected and configured).

---

**Note**

If "Safe Torque Off" is selected and de-selected through one channel within 2 seconds, the pulses are suppressed without a message being output.

---

**Restart after the "Safe Torque Off" function has been selected**

1. Deselect the function in each monitoring channel via the input terminals.
2. Issue drive enable signals.
3. Switch the drive back on.
  - 1/0 edge at input signal "ON/OFF1"
  - 0/1 edge at input signal "ON/OFF1" (switch on drive)
4. Operate the drives again.

**Response time for the "Safe Torque Off" function**

For 200 V variant servo drives, the STO response time in the worst case is 15 ms. For 400 V variant servo drives, the STO response time in the worst case is 5 ms.



## 8.4.2 Forced dormant error detection

### Forced dormant error detection or test of the switch-off signal paths for Safety Integrated Basic Functions

The forced dormant error detection function at the switch-off signal paths is used to detect software/hardware faults at both monitoring channels in time and is automated by means of activation/deactivation of the "Safe Torque Off" function.

To fulfill the requirements of ISO 13849-1:2015 regarding timely error detection, the two switch-off signal paths must be tested at least once within a defined time to ensure that they are functioning properly. This functionality must be implemented by means of forced dormant error detection function, triggered either in manual mode or by the automated process.

A timer ensures that forced dormant error detection is carried out as quickly as possible.

8760 hours for the forced dormant error detection.

Once this time has elapsed, an alarm is output and remains present until forced dormant error detection is carried out.

The timer returns to the set value each time the STO function is deactivated.

When the appropriate safety devices are implemented (e.g. protective doors), it can be assumed that running machinery will not pose any risk to personnel. For this reason, only an alarm is output to inform the user that a forced dormant error detection run is due and to request that this be carried out at the next available opportunity. This alarm does not affect machine operation.

Examples of when to carry out forced dormant error detection:

- When the drives are at a standstill after the system has been switched on (POWER ON).
- When the protective door is opened.
- At defined intervals.
- In automatic mode (time and event dependent)

---

#### Note

The timer will be reset if the associated forced dormant error detection is executed. The corresponding alarm is not triggered.

The forced dormant error detection procedure of Safety Function (STO) always has to be executed through the terminals.

---

# Tuning

## 9.1 Controller overview

The SINAMICS V90 servo drive consists of three control loops:

- Current control
- Speed control
- Position control

The following block diagram shows the relationship between these three control loops:

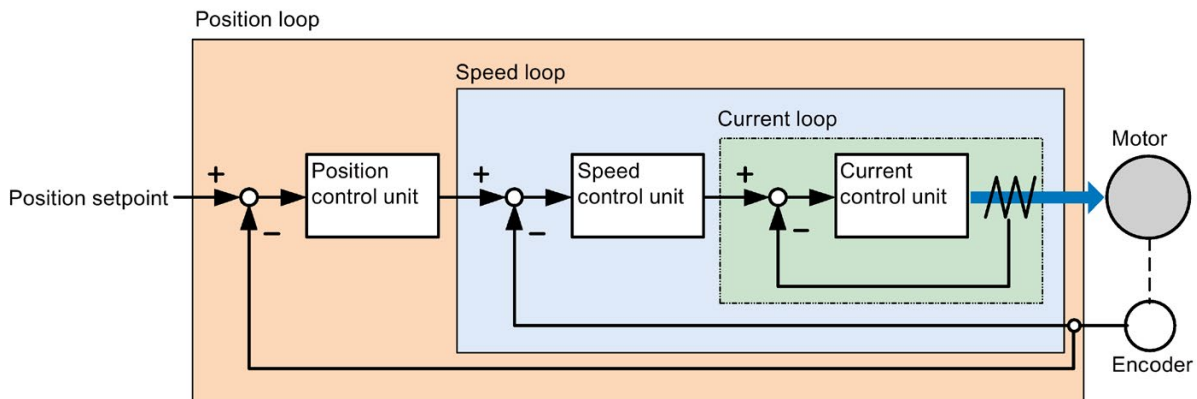

In theory, frequency width of the inside control loop **must** be wider than that of the outer control loop; otherwise, the whole control system can vibrate or have a low response level. The relationship between the frequency widths of these three control loops is as follows:

**Current loop > speed loop > position loop**

Since the current loop of SINAMICS V90 servo drive already has a perfect frequency width, it is only necessary for you to adjust the speed loop gain and the position loop gain.

## Servo gains

- Position loop gain

Position loop gain directly influences the response level of the position loop. If the mechanical system does not vibrate or produce noises, you can increase the value of position loop gain so that the response level can be increased and positioning time can be shortened.

Parameter	Range	Default	Unit	Description
p29110[0]	0.00 to 300.00	Motor dependent	1000/min	Position loop gain 1
p29110[1]	0.00 to 300.00	1.00	1000/min	Position loop gain 2

- Speed loop gain

Speed loop gain directly influences the response level of the speed loop. If the mechanical system does not vibrate or produce noises, you can increase the value of speed loop gain so that the response level can be increased.

Parameter	Range	Default	Unit	Description
p29120[0]	0 to 999999	Motor dependent	Nms/rad	Speed loop gain 1
p29120[1]	0 to 999999	0.3	Nms/rad	Speed loop gain 2

- Speed loop integral gain

With adding integral component into speed loop, the servo drive can efficiently eliminate the steady-state error of speed and give response to a small change to speed.

Generally speaking, if the mechanical system does not vibrate or produce noises, you can decrease speed loop integral gain so that the system rigidity can be increased.

If the load inertia ratio is very high or the mechanical system has a resonance factor, it must be guaranteed that the speed loop integral time constant is big enough; otherwise, the mechanical system may have a resonance.

Parameter	Range	Default	Unit	Description
p29121[0]	0 to 100000	15	ms	Speed loop integral time 1
p29121[1]	0 to 100000	20	ms	Speed loop integral time 2
p29022	1 to 10000	1	-	Load moment of inertia ratio

- Position loop feed forward gain

With position loop feed forward gain, the responsiveness level can be increased. If the position loop feed forward gain is too big, motor speed can have overshoots and the digital output signal INP can have a repeated on/off. You, therefore, must monitor the changes to speed waveform and the action of the digital output signal INP during adjustment. You can slowly adjust the position loop feed forward gain. The effect of feed forward function is not obvious if the position loop gain is too big.

Parameter	Range	Default	Unit	Description
p29111	0.00 to 200.00	0	%	Position loop feed forward gain

## 9.2 Tuning mode

Responsivity of a machine can be optimized by tuning. The responsivity is reflected by dynamic factor and determined by the servo gains that is set in the servo drive.

The servo gains are set by using a combination of parameters. These parameters influence each other so you must consider the balance between set values when setting these values.

Generally, the responsivity of a machine with high rigidity can be improved by increasing the servo gains; however, if the servo gains of a machine with low rigidity are increased, the machine can vibrate and the responsivity cannot be improved.

### NOTICE

#### Effectiveness of servo gains

The tuning function **only** uses the first group of servo gains (position loop gain 1, speed loop gain 1 and speed loop integral time 1).

The following tuning functions are available for the SINAMICS V90 servo drive.

Select a tuning mode by setting the parameter p29021.

Parameter	Range	Default	Unit	Description
p29021	0 to 5	0	-	<ul style="list-style-type: none"> <li>0: Auto tuning is disabled (manual tuning) without changing servo gains relevant parameters.</li> <li>1: One-button auto tuning. Identify the ratio of load moment of inertia and automatically adjust servo gains accordingly.</li> <li>3: Real-time auto tuning. Identify the ratio of load moment of inertia and automatically adjust servo gains in real time.</li> <li>5: Auto tuning is disabled (manual tuning). All servo gains relevant parameters are set to tuning default values.</li> </ul>

### Auto-tuning modes

The SINAMICS V90 supplies two auto-tuning modes: one-button auto tuning and real-time auto tuning. The auto tuning function can optimize control parameters with ratio of machine load moment of inertia (p29022) and set suitable current filter parameters to suppress the machine resonance automatically. You can change the dynamic performance of the system by setting different dynamic factors.

- One-button auto tuning
  - One-button auto tuning estimates the machine load moment of inertia and mechanical characteristics with internal motion commands. To achieve the desired performance, you can execute the process many times before you control the drive with the host controller. The maximum speed is limited by the rated speed.

- Real-time auto tuning
  - Real-time auto tuning estimates the machine load moment of inertia automatically while the drive is running with the host controller command. After enabling the servo on (SON), the real-time auto tuning function stays effective for the servo drive. If you do not need to estimate the load moment of inertia continuously, you can disable the function when the system performance is acceptable.

For IPos control mode, if you have obtained the machine load inertia (p29022) and desired dynamic performance with tuned dynamic factor, you can set the drive to the servo off state and set p29025.5 = 1 to make sure that there is no position overshoot on the axis.

You are recommended to save the tuned parameters when the tuning is completed and the drive performance is acceptable.

## Tuning with SINAMICS V-ASSISTANT

You are recommended to perform tuning with the engineering tool SINAMICS V-ASSISTANT. For more information, refer to SINAMICS V-ASSISTANT Online Help.

## 9.3 One-button auto tuning

---

### Note

The function is valid for firmware version V1.04.00 and higher.

---

### Note

Before using the one-button auto tuning, move the servo motor to the middle of mechanical position to avoid approaching the actual machine position limit.

---

### Pre-conditions for one-button auto tuning

- The ratio of machine load moment of inertia is still unknown and needs to be estimated.
- The motor is allowed to rotate clockwise and counter clockwise.
- The motor rotation position (p29027 defines that one revolution equals to 360 degree) is allowed by the machine.
  - For the motor with an absolute encoder: position limitation is defined by p29027
  - For the motor with an incremental encoder: the motor must be allowed to rotate freely about two rounds when tuning starts

**One-button auto tuning procedure**

Proceed as follows to perform one-button auto tuning for the SINAMICS V90 servo drive.

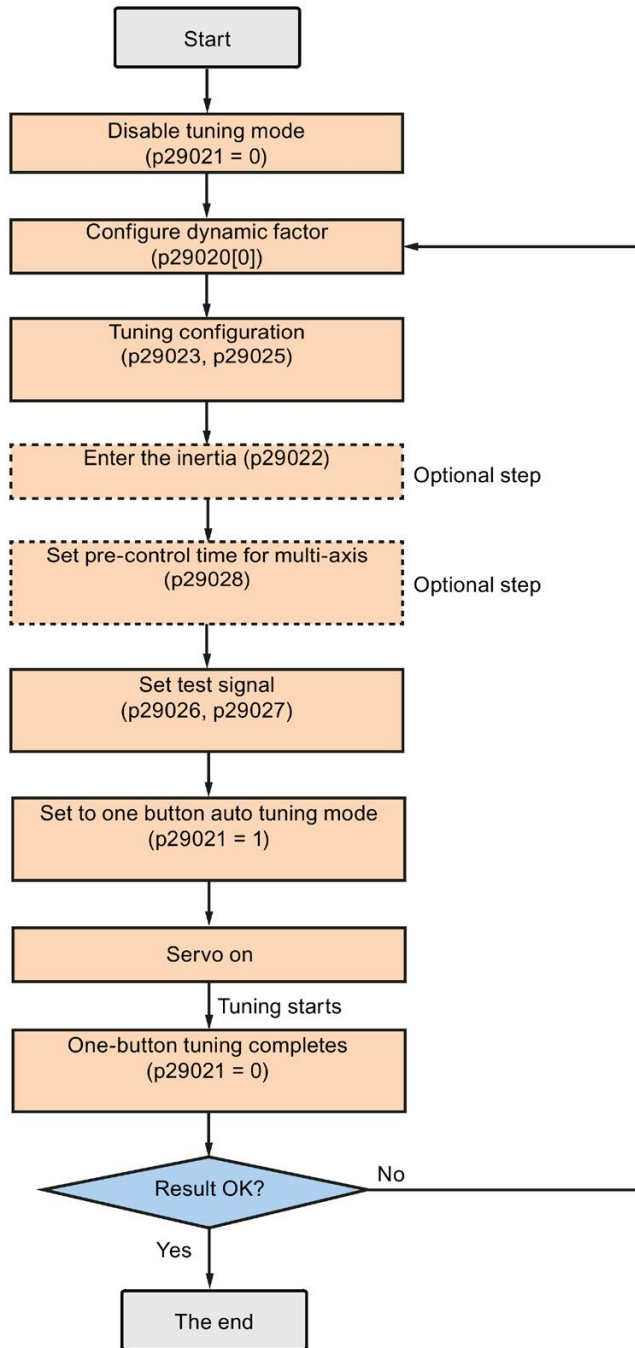

### Parameter settings

You can set the ratio of machine load moment of inertia (p29022) with the following methods:

- Enter it manually if you have known the ratio of machine load moment of inertia.
- Estimate the ratio of machine load moment of inertia with one-button auto tuning (p29023.2 = 1). When you have executed the one-button tuning many times and obtained a stable value of p29022, you can stop estimating it by setting p29023.2 = 0.

Parameter	Range	Default	Unit	Description
p29020[0...1]	1 to 35	18	-	The dynamic factor of auto tuning <ul style="list-style-type: none"> <li>• [0]: dynamic factor for one-button auto tuning</li> <li>• [1]: dynamic factor for real-time auto tuning</li> </ul>
p29021	0 to 5	0	-	Selection of a tuning mode <ul style="list-style-type: none"> <li>• 0: disabled</li> <li>• 1: one-button auto tuning</li> <li>• 3: real-time auto tuning</li> <li>• 5: disabled with default control parameters</li> </ul>
p29022	1 to 10000	1	-	Ratio of load moment of inertia
p29023	0 to 0xffff	0x0007	-	One-button auto tuning configuration
p29025	0 to 0x003f	0x0004	-	Overall tuning configuration
p29026	0 to 5000	2000	ms	Test signal duration
p29027	0 to 30000	0	°	Limit rotation position of the motor
p29028	0.0 to 60.0	7.5	ms	Pre-control time constant

Parameter p29028 is available when the multi-axis interpolation function is activated (p29023.7 = 1). If the axes are used as the interpolation axes, you need to set the same pre-control time constants (p29028) for them. After tuning is completed, you need to manually set the same position loop gains (p29110 [0]) for them if the tuning results are different.

You can configure the dynamic factor of the servo system with the parameter p29020. Higher dynamic factor means higher tracking ability and shorter settling time but also higher possibility of resonance. You should find a desired dynamic factor within a resonance-free range.

A total of 35 dynamic factors are available for the SINAMICS V90 servo drive:

Dynamic factor (p29020)	Machine rigidity
1	Low
2	↑
...	
17	
18	Middle
19	↓
...	
35	
	High

If the dynamic factor setting cannot be increased up to the desired level because of machine resonance beyond 250 Hz, the function of resonance suppression can be used to suppress machine resonance and thus increase dynamic factor. Refer to Section "Resonance suppression (Page 297)" for detailed information about the function of resonance suppression.

---

#### Note

The tuning configuration parameters must be set carefully when the auto tuning function is disabled (p29021=0).

After servo on, the motor will run with the test signal.

When the one-button auto tuning process completes successfully, parameter p29021 will be set to 0 automatically. You can also set the parameter p29021 to 0 before servo on to interrupt the one-button tuning process. Before you save the parameters on the drive, make sure that p29021 has changed to 0.

When the one-button auto tuning process completes successfully, bit 0 of parameter p29300 will be set to 0 automatically or remain unchanged (= 0), which means the drive is in "S OFF" state.

---

#### Note

Do not use the JOG function when you use the one-button tuning function.

---

#### Note

After the one-button tuning is activated, no operation will be allowed except the servo off and quick stop with the digital input EMGS.

---

With one-button auto tuning, the servo drive can automatically estimate the ratio of load moment of inertia and set the following relevant parameters accordingly.

Parameter	Range	Default	Unit	Description
p1414	0 to 3	0	-	Speed setpoint filter activation
p1415	0 to 2	0	-	Speed setpoint filter 1 type
p1417	0.5 to 16000	1999	Hz	Speed setpoint filter 1 denominator natural frequency
p1418	0.001 to 10	0.7	-	Speed setpoint filter 1 denominator damping
p1419	0.5 to 16000	1999	Hz	Speed setpoint filter 1 numerator natural frequency
p1420	0.001 to 10	0.7	-	Speed setpoint filter 1 numerator damping
p1441	0 to 50	0	ms	Actual speed smoothing time
p1656	0 to 15	1	-	Activates current setpoint filter
p1658	0.5 to 16000	1999	Hz	Current setpoint filter 1 denominator natural frequency
p1659	0.001 to 10	0.7	-	Current setpoint filter 1 denominator damping
p2533	0 to 1000	0	ms	LR position setpoint filter time constant
p2572	1 to 2000000	Motor dependent	1000 LU/s <sup>2</sup>	IPos maximum acceleration



Parameter	Range	Default	Unit	Description
p2573	1 to 2000000	Motor dependent	1000 LU/s <sup>2</sup>	IPos maximum deceleration
p29022	1 to 10000	1	-	Ratio of load moment of inertia
p29110[0]	0.00 to 300.00	Motor dependent	1000/min	Position loop gain 1
p29120[0]	0 to 999999	Motor dependent	Nms/rad	Speed loop gain 1
p29121[0]	0 to 100000	15	ms	Speed loop integral time 1
p29111	0.00 to 200.00	0.00	%	Position loop feed forward gain

After one-button tuning, four current setpoint filters can be activated at most. The following parameters related to the filters may be tuned accordingly.

Parameter	Range	Default	Unit	Description
p1663	0.5 to 16000	1000	Hz	Natural frequency of current notch filter 2 denominator.
p1664	0.001 to 10	0.3	-	Damp of current notch filter 2 denominator.
p1665	0.5 to 16000	1000	Hz	Natural frequency of current notch filter 2 numerator.
p1666	0.0 to 10	0.01	-	Damp of current notch filter 2 numerator.
p1668	0.5 to 16000	1000	Hz	Natural frequency of current notch filter 3 denominator.
p1669	0.001 to 10	0.3	-	Damp of current notch filter 3 denominator.
p1670	0.5 to 16000	1000	Hz	Natural frequency of current notch filter 3 numerator.
p1671	0.0 to 10	0.01	-	Damp of current notch filter 3 numerator.
p1673	0.5 to 16000	1000	Hz	Natural frequency of current notch filter 4 denominator.
p1674	0.001 to 10	0.3	-	Damp of current notch filter 4 denominator.
p1675	0.5 to 16000	1000	Hz-	Natural frequency of current notch filter 4 numerator.
p1676	0.0 to 10	0.01	-	Damp of current notch filter 4 numerator.

#### Note

After one-button auto tuning is activated, do not change other auto tuning related control/filter parameters since these parameters can be set automatically and your changes will not be accepted.

#### Note

One-button auto tuning may cause some changes of the control parameters. When the system rigidity is low, this may lead to a situation that when you set EMGS = 0, the motor needs take long time to stop.

## 9.4 Real-time auto tuning

With real-time auto tuning, the servo drive can automatically estimate the ratio of load moment of inertia and set the optimum control parameters.

### Pre-conditions for the real-time auto tuning

- The drive must be controlled by the host controller.
- The machine actual load moment of inertia is different when the machine moves to the different positions.
- Make sure that the motor has multiple accelerations and decelerations. Step command is recommended.
- Machine resonance frequency changes when the machine is running.

### Real-time auto tuning procedure

Proceed as follows to perform real-time auto tuning for the SINAMICS V90 servo drive.

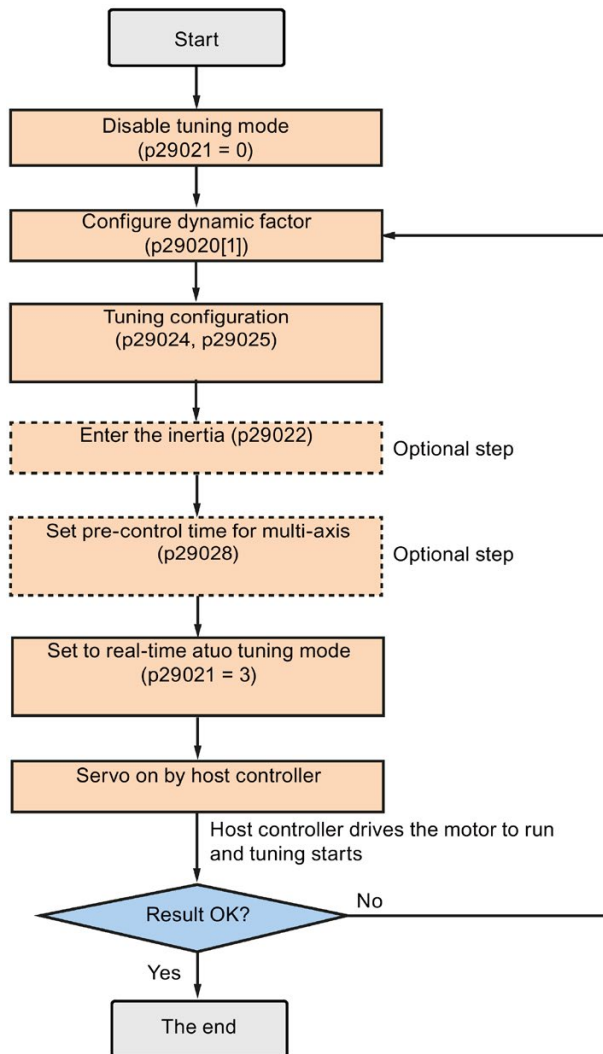

### Parameter settings

You can set the ratio of machine load moment of inertia (p29022) with the following methods:

- Enter it manually if you have known the ratio of machine load moment of inertia
- Use the ratio of machine load moment of inertia estimated by the one-button auto tuning function directly
- Estimate the ratio of machine load moment of inertia with real-time auto tuning (p29024.2 = 1). When you have obtained a stable value of p29022, you can stop estimating it by setting p29024.2 = 0.

Parameter	Range	Default	Unit	Description
p29020[0...1]	1 to 35	18	-	The dynamic factor of auto tuning. <ul style="list-style-type: none"> <li>• [0]: dynamic factor for one-button auto tuning</li> <li>• [1]: dynamic factor for real-time auto tuning</li> </ul>
p29021	0 to 5	0	-	Selection of a tuning mode. <ul style="list-style-type: none"> <li>• 0: disabled</li> <li>• 1: one-button auto tuning</li> <li>• 3: real-time auto tuning</li> <li>• 5: disable with default controller parameters</li> </ul>
p29022	1 to 10000	1	-	Ratio of load moment of inertia
p29024	0 to 0xffff	0x004c	-	Real-time auto tuning configuration
p29025	0 to 0x003f	0x0004	-	Overall tuning configuration
p29028	0.0 to 60.0	7.5	ms	Pre-control time constant

Parameter p29028 is available when the multi-axis interpolation function is activated (p29024.7 = 1). If the axes are used as the interpolation axes, you need to set the same pre-control time constants (p29028) for them. After tuning is completed, you need to manually set the same position loop gains (p29110 [0]) for them if the tuning results are different.

You can configure the dynamic factor of the servo system with the parameter p29020. Higher dynamic factor means higher tracking ability and shorter settling time but also higher possibility of resonance. You should find a desired dynamic factor within a resonance-free range.

35 dynamic factors are available for the SINAMICS V90 servo drive.

Dynamic factor (p29020)	Machine rigidity
1	Low
2	↑
...	
17	
18	Middle

Dynamic factor (p29020)	Machine rigidity
19	↓
...	
35	

If the dynamic factor setting cannot be increased up to the desired level because of machine resonance beyond 250 Hz, the function of resonance suppression can be used to suppress machine resonance and thus increase dynamic factor. Refer to Section "Resonance suppression (Page 297)" for detailed information about the function of resonance suppression.

#### Note

The tuning configuration parameters must be set carefully when the auto tuning function is disabled (p29021=0).

During tuning, you can modify the dynamic factor with p29020[1] to obtain the different dynamic performance after p29022 has been tuned and accepted by the drive.

After servo on, the real-time auto tuning function will always effective for the servo drive. If you want to end or interrupt the real-time auto tuning process, set the drive to the servo off state then set p29021 to 0.

The following relevant parameters can be continuous set in real time when you are using the real-time auto tuning.

Parameter	Range	Default	Unit	Description
p1417	0.5 to 16000	1999	Hz	Speed setpoint filter 1 denominator natural frequency
p1419	0.5 to 16000	1999	Hz	Speed setpoint filter 1 numerator natural frequency
p29022	1 to 10000	1	-	Ratio of load moment of inertia
p29110[0]	0.00 to 300.00	Motor dependent	1000/min	Position loop gain 1
p29120[0]	0 to 999999	Motor dependent	Nms/rad	Speed loop gain 1
p29121[0]	0 to 100000	15	ms	Speed loop integral time 1
p29111	0.00 to 200.00	0.00	%	Position loop feed forward gain

#### Note

When using the real-time auto tuning function, if the default values are inappropriate, the host controller cannot run the motor. To run the motor with the host controller, you need to let the drive tune the parameters automatically through trial run with the real-time auto tuning function. After the tuning is completed, the host controller can run the motor.

**Note**

After the real-time auto tuning is activated, do not change other auto tuning related control/filter parameters since these parameters can be set automatically and your changes will not be accepted.

---

**Note**

The real-time auto tuning may not be performed properly if the following conditions are not satisfied:

- Accelerate the motor for 100 ms or more with the acceleration torque.
- The acceleration/deceleration torque is 15% or more of the rated torque.

Under operating conditions that impose sudden disturbance torque during acceleration/deceleration or on a machine that its rigidity is poor, auto tuning may not function properly, either. In such cases, use the one-button auto tuning or manual tuning to optimize the drive.

---

## 9.5 Manual tuning

When the auto tuning cannot reach expected tuning results, you can disable the auto tuning function by setting the parameter p29021 and manually perform tuning:

- p29021=5: auto tuning function is disabled and all control parameters are reset to tuning default values.
- p29021=0: auto tuning function is disabled without changing control parameters.

### Procedure for manual tuning

Follow the procedure below to perform manual tuning:

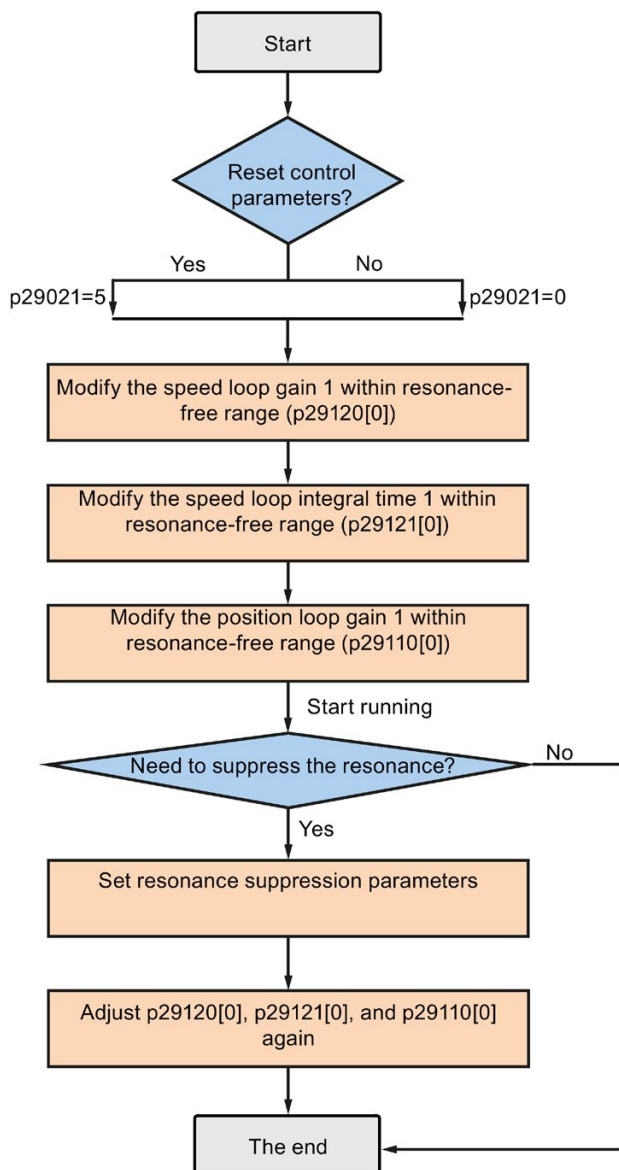

**Note**

**Resonance suppression**

For detailed information about the resonance suppression, refer to Section "Resonance suppression (Page 297)".

**Parameter settings**

You need to set the following servo gains related parameters manually when using the manual tuning function.

Parameter	Range	Default	Unit	Description
p2533	0 to 1000	0	ms	LR position setpoint filter time constant
p2572	1 to 2000000	Motor dependent	1000 LU/s <sup>2</sup>	IPos maximum acceleration
p2573	1 to 2000000	Motor dependent	1000 LU/s <sup>2</sup>	IPos maximum deceleration
p29110[0]	0.00 to 300.00	Motor dependent	1000/min	Position loop gain 1
p29120[0]	0 to 999999	Motor dependent	Nms/rad	Speed loop gain 1
p29121[0]	0 to 100000	15	ms	Speed loop integral time 1
p29111	0.00 to 200.00	0.00	%	Position loop feed forward gain

## 9.6 Resonance suppression

The resonance suppression function is filter (notch filter) function. It detects mechanical resonance at a frequency between 250 Hz and 1500 Hz, and decreases the gain of specific frequency (by automatically setting notch filter) to suppress the mechanical resonance.

Now four current setpoint filters are available for the V90 servo drive. Filter 1 is lowpass filter. Filter 2, filter 3 and filter 4 are band damp filters.

The gain decreasing frequency, width as well as depth can be set by setting the notch filter:

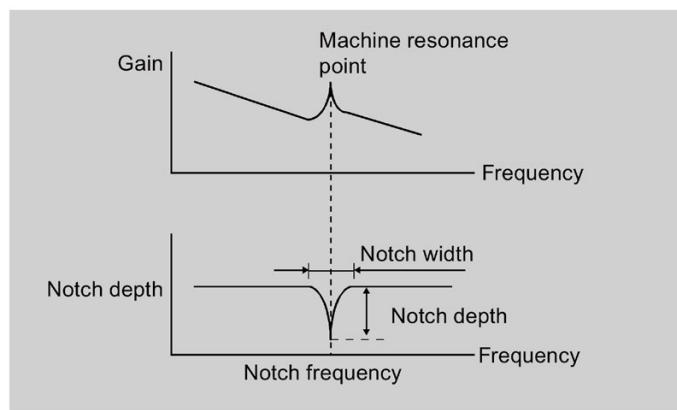

## Using the resonance suppression function

### Note

The resonance suppression function is used together with the auto tuning function. In real-time auto tuning and one-button auto tuning mode, the function is activated by default.

When you use real-time auto tuning function, you are recommended to disable the resonance suppression function to get a high dynamic performance if there is no resonance in the machine.

The function can be activated/deactivated with the following parameters:

- For one-button auto tuning: bit 1 of p29023
- For real-time auto tuning: bit 6 of p29024

## Resonance suppression with one-button auto tuning (p29021=1, p29023.1=1)

Before you use the resonance suppression function with one-button auto tuning, make sure the load is mounted as required and the servo motor can rotate freely. When the one-button auto tuning process completes successfully, the servo drive automatically sets the following notch filter relevant parameters with real machine characteristic. Four current setpoint filters can be activated at most.

Parameter	Range	Default	Unit	Description
p1663	0.5 to 16000	1000	Hz	Natural frequency of current notch filter 2 denominator.
p1664	0.001 to 10	0.3	-	Damp of current notch filter 2 denominator.
p1665	0.5 to 16000	1000	Hz	Natural frequency of current notch filter 2 numerator.
p1666	0.0 to 10	0.01	-	Damp of current notch filter 2 numerator.
p1668	0.5 to 16000	1000	Hz	Natural frequency of current notch filter 3 denominator.
p1669	0.001 to 10	0.3	-	Damp of current notch filter 3 denominator.
p1670	0.5 to 16000	1000	Hz	Natural frequency of current notch filter 3 numerator.
p1671	0.0 to 10	0.01	-	Damp of current notch filter 3 numerator.
p1673	0.5 to 16000	1000	Hz	Natural frequency of current notch filter 4 denominator.
p1674	0.001 to 10	0.3	-	Damp of current notch filter 4 denominator.
p1675	0.5 to 16000	1000	Hz	Natural frequency of current notch filter 4 numerator.
p1676	0.0 to 10	0.01	-	Damp of current notch filter 4 numerator.

### Note

**Notch filter remains active when the resonance suppression function is activated automatically.**

After one-button tuning is completed, four filters can be activated at most. You can deactivate the notch filters by setting the parameter p1656.



### Resonance suppression with real-time auto tuning (p29021=3, p29024.6=1)

When you choose to use the resonance suppression function with real-time auto tuning, the servo drive performs real-time detection of the resonance frequency and configures the following notch filter relevant parameters accordingly.

Parameter	Range	Default	Unit	Description
p1663	0.5 to 16000	1000	Hz	Natural frequency of current notch filter 2 denominator.
p1664	0.001 to 10	0.3	-	Damp of current notch filter 2 denominator.
p1665	0.5 to 16000	1000	Hz	Natural frequency of current notch filter 2 numerator.
p1666	0.0 to 10	0.01	-	Damp of current notch filter 2 numerator.

### Resonance suppression with manual tuning (p29021=0)

When both the resonance suppression with real-time auto tuning and one-button tuning mode cannot reach the suppression effect, you can do the resonance suppression by manually setting the following parameters.

Parameter	Range	Default	Unit	Description
p1663	0.5 to 16000	1000	Hz	Natural frequency of current notch filter 2 denominator.
p1664	0.001 to 10	0.3	-	Damp of current notch filter 2 denominator.
p1665	0.5 to 16000	1000	Hz	Natural frequency of current notch filter 2 numerator.
p1666	0.0 to 10	0.01	-	Damp of current notch filter 2 numerator.
p1668	0.5 to 16000	1000	Hz	Natural frequency of current notch filter 3 denominator.
p1669	0.001 to 10	0.3	-	Damp of current notch filter 3 denominator.
p1670	0.5 to 16000	1000	Hz	Natural frequency of current notch filter 3 numerator.
p1671	0.0 to 10	0.01	-	Damp of current notch filter 3 numerator.
p1673	0.5 to 16000	1000	Hz	Natural frequency of current notch filter 4 denominator.
p1674	0.001 to 10	0.3	-	Damp of current notch filter 4 denominator.
p1675	0.5 to 16000	1000	Hz	Natural frequency of current notch filter 4 numerator.
p1676	0.0 to 10	0.01	-	Damp of current notch filter 4 numerator.

Assume the notch frequency is  $f_{sp}$ , notch width is  $f_{BB}$ , and notch depth is  $K$ , then the filter parameters can be calculated as follows:

$$p1663=p1665=f_{sp}$$

$$p1664=f_{BB} / (2 \times f_{sp})$$

$$p1666=(f_{BB} \times 10^{(k/20)}) / (2 \times f_{sp})$$

## 9.7 Low frequency vibration suppression

The low frequency vibration suppression function is a position setpoint filter function. It can suppress the vibration from 0.5 Hz to 62.5 Hz. The function is available in IPos control mode.

### Related parameters

When you use the vibration suppression function, you need to configure the following parameters accordingly:

Parameter	Range	Default	Unit	Description
p29035	0 to 1	0	-	Vibration suppression activation. <ul style="list-style-type: none"> <li>0: disable</li> <li>1: enable</li> </ul>
p31581	0 to 1	0	-	Vibration suppression filter type. <ul style="list-style-type: none"> <li>0: filter type rugged</li> <li>1: filter type sensitive</li> </ul>
p31585	0.5 to 62.5	1	Hz	Vibration suppression filter frequency.
p31586	0 to 0.99	0.03	-	Vibration suppression filter damp.

### Operating steps

Step	Description	Comment
①	Set the drive to "S OFF" state.	
②	Select the filter type by p31581.	Vibration suppression filter type. <ul style="list-style-type: none"> <li>0: filter type rugged</li> <li>1: filter type sensitive</li> </ul>
③	Set the suppression frequency by p31585.	You can set the suppression frequency from 0.5 Hz to 62.5 Hz.
④	Set the damp of the filter by p31586.	You can set the damp from 0 to 0.99.
⑤	Set the control mode for the drive by p29003.	
⑥	Enable the vibration suppression function by p29035.	Set p29035 = 1 to activate the function.
⑦	Set the drive to "S ON" state.	

## 9.8 Gain switching

### Note

The Gain Switching function is **not** available in **T** mode (torque control mode).

The function of auto-tuning must be disabled so that the function of gain switching can be available.

With this function, you can implement the following operations:

- Increase the gains during servo lock and decrease gains to reduce noise during rotation.
- Increase the gains during settling to shorten the stop settling time.
- Switch between two groups of gains using an external signal (G-CHANGE) to ensure stability of the servo system because the load inertia moment ratio varies greatly during a stop (for example, a large load is mounted on a carrier).

### Selection of a gain switching mode

Five gain switching modes in total are available:

- Gain switching disabled
- Gain switching using digital input signal (G-CHANGE)
- Gain switching using position deviation
- Gain switching using position setpoint frequency
- Gain switching using actual speed

You can select one of the five modes by setting parameter p29130:

Parameter	Value	Description
p29130	0 (default)	The function of gain switching is disabled. Only the first group of gains is valid and the function of PI to P switching of speed controller is enabled.
	1	Gain switching using digital input signal (G-CHANGE). When G-CHANGE is 0, the first group of gains is selected; when G-CHANGE is 1, the second one is selected.
	2	Gain switching using position deviation. In the position control mode, gain switching can be decided by position deviation. If the position deviation is less than preset value, the first group of gains is selected; otherwise, the second one is selected.
	3	Gain switching using position setpoint frequency. In the position control mode, gain switching can also be decided by position setpoint frequency. If the position setpoint frequency is less than preset value, the first group of gain is selected; otherwise, the second one is selected.
	4	In the speed control mode, gain switching can be decided by actual speed. If the actual speed is below preset value; otherwise, the second one is selected.

### 9.8.1 Gain switching using an external digital input signal (G-CHANGE)

#### DI settings

- Position control mode

Signal	Pin assignment	Setting	Description
G-CHANGE	X8-9 (factory setting)	0	The first group of gains is selected.
		1	The second group of gains is selected.

- Speed control mode

Signal	Pin assignment	Setting	Description
G-CHANGE	To be assigned	0	The first group of gains is selected.
		1	The second group of gains is selected.

#### Parameter settings (p29130 = 1)

Parameter	Range	Default	Unit	Description
p29110[0]	0.00 to 300.00	Motor dependent	1000/min	Position loop gain 1
p29110[1]	0.00 to 300.00	1.00	1000/min	Position loop gain 2
p29120[0]	0 to 999999	Motor dependent	Nms/rad	Speed loop gain 1
p29120[1]	0 to 999999	0.3	Nms/rad	Speed loop gain 2
p29121[0]	0 to 100000	15	ms	Speed loop integral time 1
p29121[1]	0 to 100000	20	ms	Speed loop integral time 2
p29139	8 to 1000	20	ms	Time constant to smooth the switching between gain sets

#### Timing diagram

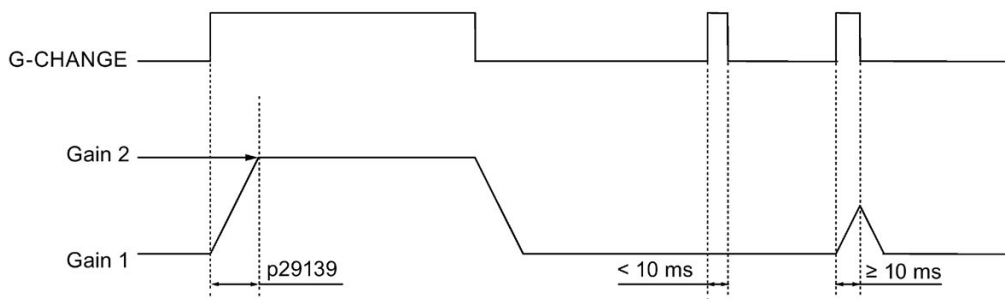

#### Note

If the pulse duration is shorter than 10 ms, there is no reaction.

## 9.8.2 Gain switching using position deviation

Parameter settings (p29130 = 2)

Parameter	Range	Default	Unit	Description
p29110[0]	0.00 to 300.00	Motor dependent	1000/min	Position loop gain 1
p29110[1]	0.00 to 300.00	1.00	1000/min	Position loop gain 2
p29120[0]	0 to 999999	Motor dependent	Nms/rad	Speed loop gain 1
p29120[1]	0 to 999999	0.3	Nms/rad	Speed loop gain 2
p29121[0]	0 to 100000	15	ms	Speed loop integral time 1
p29121[1]	0 to 100000	20	ms	Speed loop integral time 2
p29131	0 to 2147483647	100	LU	Position deviation threshold for automatically triggering gain switching
p29139	8 to 1000	20	ms	Time constant to smooth the switching between gain sets

### Timing diagram

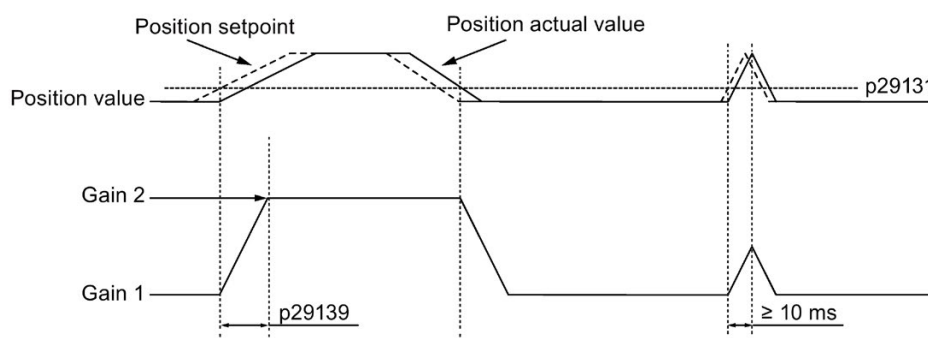

## 9.8.3 Gain switching using position setpoint frequency

Parameter settings (p29130 = 3)

Parameter	Range	Default	Unit	Description
p29110[0]	0.00 to 300.00	Motor dependent	1000/min	Position loop gain 1
p29110[1]	0.00 to 300.00	1.00	1000/min	Position loop gain 2
p29120[0]	0 to 999999	Motor dependent	Nms/rad	Speed loop gain 1
p29120[1]	0 to 999999	0.3	Nms/rad	Speed loop gain 2

Parameter	Range	Default	Unit	Description
p29121[0]	0 to 100000	15	ms	Speed loop integral time 1
p29121[1]	0 to 100000	20	ms	Speed loop integral time 2
p29132	0 to 2147000064	100	1000 LU/min	Position setpoint frequency threshold for automatically triggering gain switching
p29139	8 to 1000	20	ms	Time constant to smooth the switching between gain sets

Timing diagram

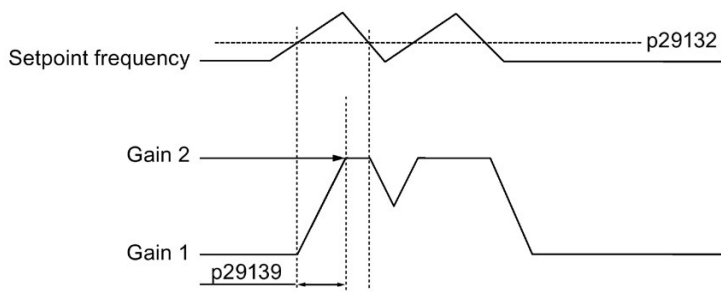

9.8.4 Gain switching using actual speed

Parameter settings (p29130 = 4)

Parameter	Range	Default	Unit	Description
p29110[0]	0.00 to 300.00	Motor dependent	1000/min	Position loop gain 1
p29110[1]	0.00 to 300.00	1.00	1000/min	Position loop gain 2
p29120[0]	0 to 999999	Motor dependent	Nms/rad	Speed loop gain 1
p29120[1]	0 to 999999	0.3	Nms/rad	Speed loop gain 2
p29121[0]	0 to 100000	15	ms	Speed loop integral time 1
p29121[1]	0 to 100000	20	ms	Speed loop integral time 2
p29133	0 to 2147000064	100	rpm	Speed threshold for automatically triggering gain switching
p29139	8 to 1000	20	ms	Time constant to smooth the switching between gain sets

## Timing diagram

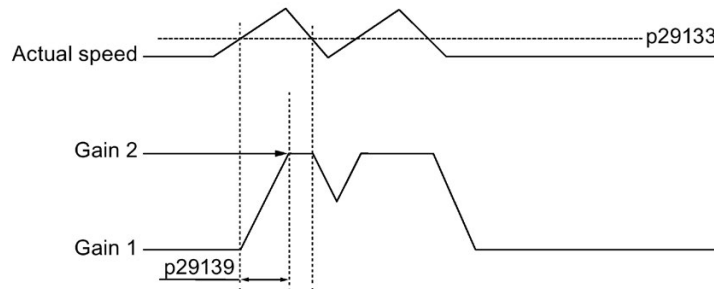

## 9.9 PI/P switching

### Note

#### PI/P switching

Function of PI/P switching is **not** available for the **T** mode (torque control mode).

The functions of auto-tuning and gain switching must be disabled so that the function of PI/P switching can be available.

The PI/P switching will respond with a delay time of several milliseconds.

The function of PI/P switching is used to switch from **PI** (Proportional/Integral) control of speed controller to **P** (Proportional) control. With this function, you can:

- shorten the position setting time (for the position control mode).
- avoid overshooting of actual speed value during acceleration or deceleration (for the speed control mode).
- avoid unnecessary torque when the target position is at a mechanical limitation (for the position control mode).

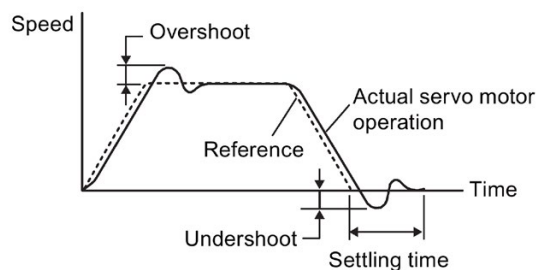

### Selection of a switching mode for PI/P switching

Five switching modes in total are available for PI/P switching:

- using torque setpoint
- using an external digital input signal (G-CHANGE)

- using speed setpoint
- using acceleration setpoint
- using pulse deviation

You can select one of the switching modes by setting parameter p29140:

Parameter	Value	Description
p29140	0 (default)	Disabled.
	1	Torque is higher than a parameterizable setting value.
	2	Using the digital input signal (G-CHANGE)
	3	Speed is higher than a parameterizable setting value.
	4	Acceleration is higher than a parameterizable setting value.
	5	Pulse deviation is higher than a parameterizable setting value.

**Example**

Without the function of PI/P switching	With the function of PI/P switching
--	-------------------------------------

**Example 1:** If the PI/P switching is not used, the speed of the motor may overshoot or undershoot due to torque saturation during acceleration or deceleration. The mode switching function suppresses torque saturation and eliminates the overshooting or undershooting of the motor speed.

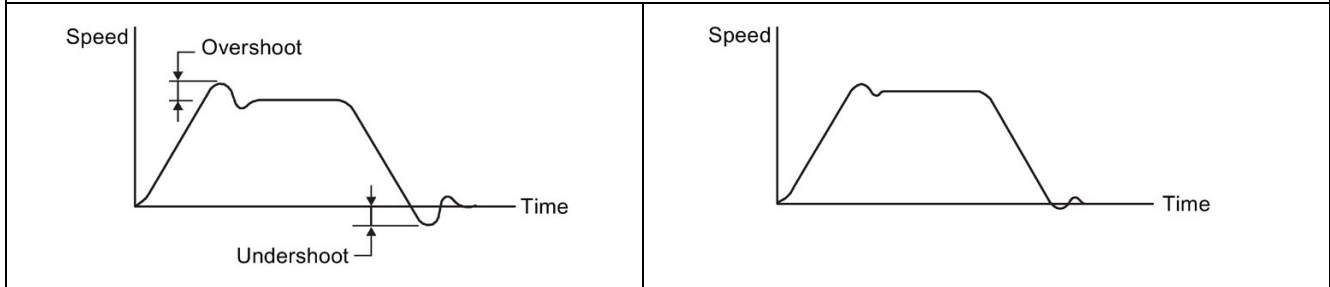

**Example 2:** The function of PI/P switching can be used to suppress overshooting and undershooting when speed loop gain is increased

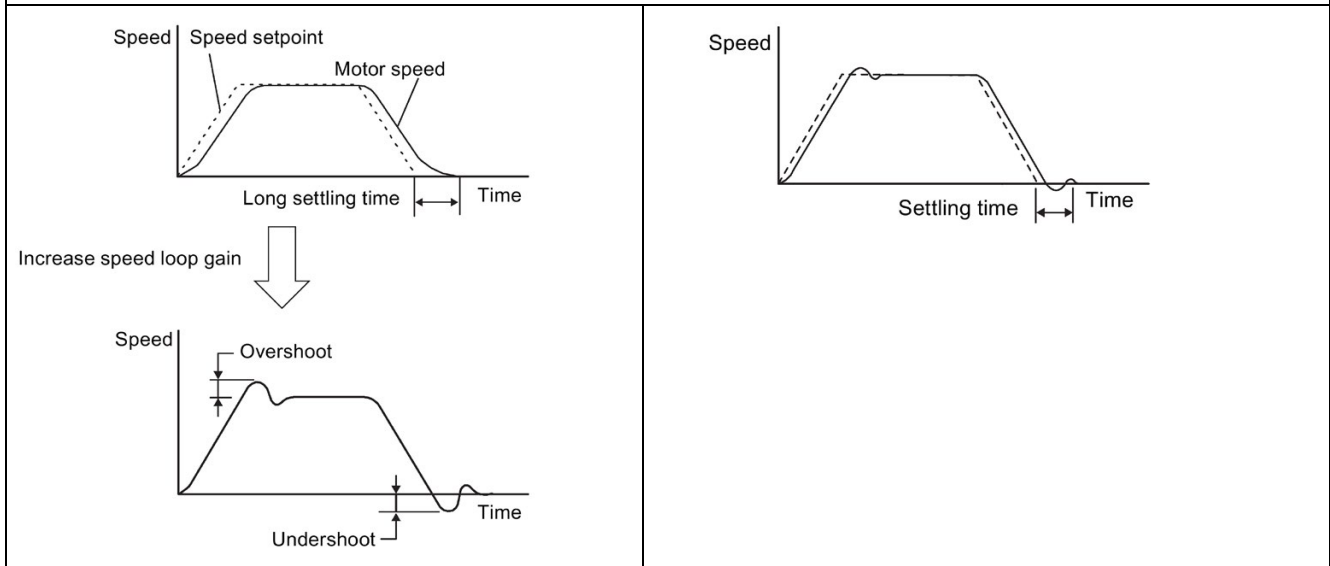



### 9.9.1 PI/P switching using torque setpoint

When torque setpoint exceeds preset torque value (p29141), the speed loop is switched from PI control to P control.

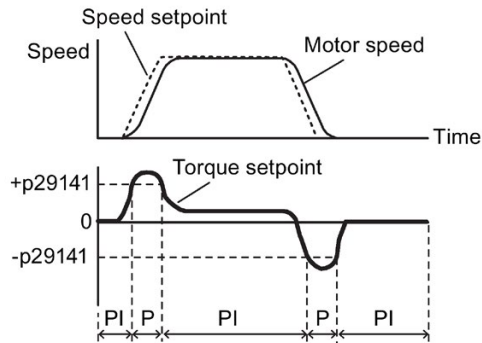

#### Parameter settings

Parameter	Value range	Setting value	Unit	Description
p29140	0 to 5	1	-	Switches PI control to P control using torque setpoint
p29141	0 to 300	200 (default)	%	Torque threshold for automatically triggering PI to P switch
p29120[0]	0 to 999999	0.3 (default)	Nms/rad	Speed loop gain 1
p29121[0]	0 to 100000	15 (default)	ms	Speed loop integral time 1

#### Note

##### Speed setpoint

For detailed information about speed setpoint, refer to "Configuring speed setpoint (Page 226)".

##### Torque setpoint

For detailed information about torque setpoint, refer to "Torque setpoint (Page 232)".

### 9.9.2 PI/P switching using an external digital input signal (G-CHANGE)

#### DI settings

- Position control mode

Signal	Pin assignment	Setting	Description
G-CHANGE	X8-9 (factory setting)	0	The first group of gains is selected.
		1	The second group of gains is selected.

- Speed control mode

Signal	Pin assignment	Setting	Description
G-CHANGE	To be assigned	0	The first group of gains is selected.
		1	The second group of gains is selected.

**Parameter settings**

Parameter	Value range	Setting value	Unit	Description
p29140	0 to 5	2	-	Switches PI control to P control using an external digital input signal (G-CHANGE)
p29120[0]	0 to 999999	0.3 (default)	Nms/rad	Speed loop gain 1
p29121[0]	0 to 100000	15 (default)	ms	Speed loop integral time 1

**Timing diagram**

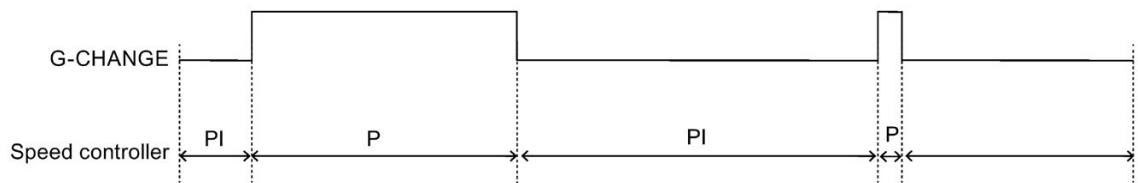

**9.9.3 PI/P switching using speed setpoint**

When the speed setpoint exceeds the preset speed value (p29142), the speed loop is switched from PI control to P control.

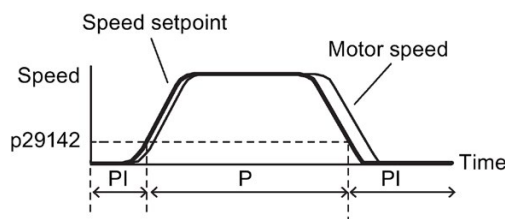

**Parameter settings**

Parameter	Value range	Setting value	Unit	Description
p29140	0 to 5	3	-	Switches PI control to P control using speed setpoint.
p29142	0 to 210000	2000 (default)	rpm	Speed threshold for automatically triggering PI to P switch.
p29120[0]	0 to 999999	0.3 (default)	Nms/rad	Speed loop gain 1
p29121[0]	0 to 100000	15 (default)	ms	Speed loop integral time 1

**Note**

For detailed information about speed setpoint, refer to "Configuring speed setpoint (Page 226)".

### 9.9.4 PI/P switching using acceleration setpoint

When the motor acceleration exceeds the preset acceleration rate (p29143), the speed loop is switched from PI control to P control.

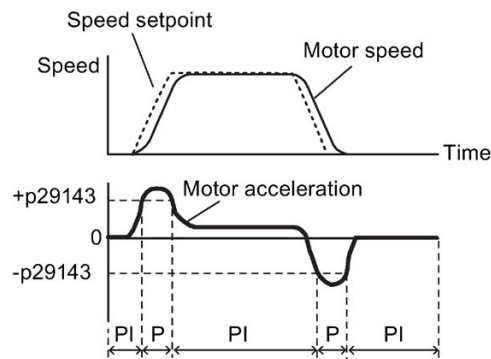

#### Parameter settings

Parameter	Value range	Setting value	Unit	Description
p29140	0 to 5	4	-	Switches PI control to P control using acceleration setpoint.
p29143	0 to 30000	20 (default)	rev/s <sup>2</sup>	Acceleration threshold for automatically triggering PI to P switch.
p29120[0]	0 to 999999	0.3 (default)	Nms/rad	Speed loop gain 1
p29121[0]	0 to 100000	15 (default)	ms	Speed loop integral time 1

**Note**

**Speed setpoint**

For detailed information about speed setpoint, refer to "Configuring speed setpoint (Page 226)".

**Acceleration**

For detailed information about acceleration, refer to "Setting fixed position setpoint (Page 207)" of the internal position control mode.

### 9.9.5 PI/P switching using pulse deviation

The speed loop is switched from PI control to P control when the pulse deviation exceeds the preset value (p29144).

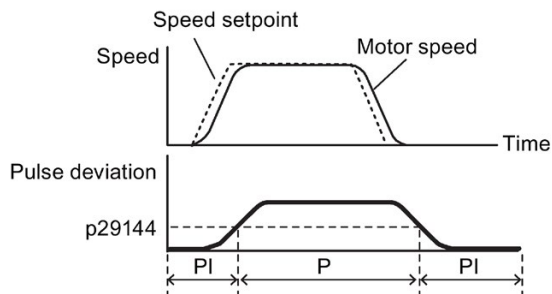

#### Parameter settings

Parameter	Value range	Setting value	Unit	Description
p29140	0 to 5	5	-	Switches PI control to P control using pulse deviation
p29144	0 to 2147483647	30000 (default)	-	Pulse deviation threshold for automatically triggering PI to P switching
p29120[0]	0 to 999999	0.3 (default)	Nms/rad	Speed loop gain 1
p29121[0]	0 to 100000	15 (default)	ms	Speed loop integral time 1

#### Note

##### Speed setpoint

For detailed information about speed setpoint, refer to "Configuring speed setpoint (Page 226)".

# Parameters

## 10.1 Overview

The section below lists all the parameters of the SINAMICS V90 servo drive.

### Parameter number

Numbers prefixed with an "r" indicate that parameter is a read-only parameter.

Numbers prefixed with a "p" indicate that the parameter is an editable parameter.

### Effective

This indicates the conditions for making parameterization effective. Two conditions are possible:

- IM (**I**mmediately): Parameter value becomes effective immediately after changing.
- RE (**R**eset): Parameter value becomes effective after repower-on.

### Can be changed

This indicates when the parameter can be changed. Two states are possible:

- U (Run): Can be changed in the "**R**unning" state when the drive is in "S ON" state. The "RDY" LED lights up green.
- T (Ready to run): Can be changed in the "**R**eady" state when the drive is in "S OFF" state. The "RDY" LED lights up red.

---

### Note

When judging the state of the drive according to the "RDY" LED, ensure that no faults or alarms exist.







---

## Data type

Date type	Abbreviation	Description
Integer16	I16	16-bit integer
Integer32	I32	32-bit integer
Unsigned8	U8	8-bit unsigned integer
Unsigned16	U16	16-bit unsigned integer
Unsigned32	U32	32-bit unsigned integer
FloatingPoint32	Float	32-bit floating point number

## Parameter groups

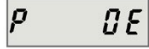
The SINAMICS V90 parameters are divided into the following groups:

Parameter group	Available parameters	Parameter group display on the BOP
Basic parameters	p290xx	
Gain adjustment parameters	p291xx	
Speed control parameters	p10xx to p14xx, p21xx	
Torque control parameters	p15xx to p16xx	
Position control parameters	p25xx to p26xx, p292xx	
I/O parameters	p293xx	
Status monitoring parameters	All read-only parameters	

## 10.2 Parameter list

### Editable parameters

The values of the parameters marked with an asterisk (\*) may be changed after commissioning. Make sure you back up the parameters first as required if you desire to replace the motor. The default values of the parameters marked with two asterisks (\*\*) are motor dependent. They may have different default values when different motors are connected.

Par. No.	Name	Min	Max	Factory Setting	Unit	Data type	Effective	Can be changed
p0748	CU invert digital outputs	0	63	0	-	U32	IM	T, U
	<b>Description:</b> Inverts the signals at the digital outputs. <ul style="list-style-type: none"> <li>Bit 0 to bit 5: invert signal for DO 1 to DO 6. <ul style="list-style-type: none"> <li>Bit = 0: not inverted</li> <li>Bit = 1: inverted</li> </ul> </li> </ul>							
p0795	Digital inputs simulation mode	1	4294967295	0	-	U32	IM	T, U
	<b>Description:</b> Sets the simulation mode for digital inputs. <ul style="list-style-type: none"> <li>Bit 0 to bit 9: set the simulation mode for DI 1 to DI 10 <ul style="list-style-type: none"> <li>Bit = 0: terminal eval</li> <li>Bit = 1: simulation</li> </ul> </li> </ul>							
	<b>Note:</b> If a digital input is used as signal source for the function "STO" then it is not permissible to select the simulation mode and this is rejected. This parameter is not saved when data is backed up.							
p0796	Digital inputs simulation mode setpoint	1	4294967295	0	-	U32	IM	T, U
	<b>Description:</b> Sets the setpoint for the input signals in the digital input simulation mode. <ul style="list-style-type: none"> <li>Bit 0 to bit 9: set the setpoint for DI 1 to DI 10 <ul style="list-style-type: none"> <li>Bit = 0: low</li> <li>Bit = 1: high</li> </ul> </li> </ul>							
	<b>Note:</b> This parameter is not saved when data is backed up.							
p0927	Parameter authority	0000 bin	0011 bin	0011 bin	-	U16	IM	T
	<b>Description:</b> Sets the interface via which parameters can be changed. <ul style="list-style-type: none"> <li>Bit definition: <ul style="list-style-type: none"> <li>Bit 0: V-ASSISTANT</li> <li>Bit 1: BOP</li> </ul> </li> <li>Value definition for a bit: <ul style="list-style-type: none"> <li>0: read only</li> <li>1: read and write</li> </ul> </li> </ul>							
	<b>Note:</b> If p927.0 = 0, the V-ASSISTANT can only be used to read parameters, all other functions won't work.							
p1001	Fixed speed setpoint 1	-210000.000	210000.000	0.000	rpm	Float	IM	T, U
	<b>Description:</b> Sets a value for the fixed speed / velocity setpoint 1.							

Parameters

10.2 Parameter list

Par. No.	Name	Min	Max	Factory Setting	Unit	Data type	Effective	Can be changed
p1002	Fixed speed setpoint 2	-210000.000	210000.000	0.000	rpm	Float	IM	T, U
	<b>Description:</b> Sets a value for the fixed speed / velocity setpoint 2.							
p1003	Fixed speed setpoint 3	-210000.000	210000.000	00.000	rpm	Float	IM	T, U
	<b>Description:</b> Sets a value for the fixed speed / velocity setpoint 3.							
p1004	Fixed speed setpoint 4	-210000.000	210000.000	0.000	rpm	Float	IM	T, U
	<b>Description:</b> Sets a value for the fixed speed / velocity setpoint 4.							
p1005	Fixed speed setpoint 5	-210000.000	210000.000	0.000	rpm	Float	IM	T, U
	<b>Description:</b> Sets a value for the fixed speed / velocity setpoint 5.							
p1006	Fixed speed setpoint 6	-210000.000	210000.000	0.000	rpm	Float	IM	T, U
	<b>Description:</b> Sets a value for the fixed speed / velocity setpoint 6.							
p1007	Fixed speed setpoint 7	-210000.000	210000.000	0.000	rpm	Float	IM	T, U
	<b>Description:</b> Sets a value for the fixed speed / velocity setpoint 7.							
p1058	Jog 1 speed setpoint	0.00	210000.000	100.00	rpm	Float	IM	T
	<b>Description:</b> Sets the speed/velocity for Jog 1. Jogging is level-triggered and allows the motor to be incrementally moved.							
	<b>Note:</b> The parameter values displayed on the BOP are integers.							
p1082 *	Maximum speed	0.000	210000.000	1500.00 0	rpm	Float	IM	T
	<b>Description:</b> Sets the highest possible speed.							
	<b>Notice:</b> After the value has been modified, no further parameter modifications can be made.							
	<b>Note:</b> The parameter values displayed on the BOP are integers.							
	The parameter applies for both motor directions.							
	The parameter has a limiting effect and is the reference quantity for all ramp-up and ramp-down times (e.g. down ramps, ramp-function generator and motor potentiometer). The range of the parameter is different when connect with different motors.							
p1083 *	Speed limit in positive direction of rotation	0.000	210000.000	210000. 000	rpm	Float	IM	T, U
	<b>Description:</b> Sets the maximum speed for the positive direction.							
	<b>Note:</b> The parameter values displayed on the BOP are integers.							
p1086 *	Speed limit in negative direction of rotation	-210000.000	0.000	- 210000. 000	rpm	Float	IM	T, U
	<b>Description:</b> Sets the speed limit for the negative direction.							
	<b>Note:</b> The parameter values displayed on the BOP are integers.							
p1115	Ramp-function generator selection	0	1	0	-	I16	IM	T
	<b>Description:</b> Sets the ramp-function generator type.							
	Note: Another ramp-function generator type can only be selected when the motor is at a standstill.							
p1120	Ramp-function generator ramp-up time	0.000	999999.000	1	s	Float	IM	T, U
	<b>Description:</b> The ramp-function generator ramps-up the speed setpoint from standstill (setpoint = 0) up to the maximum speed (p1082) in this time.							
	<b>Dependency:</b> Refer to p1082							



Par. No.	Name	Min	Max	Factory Setting	Unit	Data type	Effective	Can be changed
p1121	Ramp-function generator ramp-down time	0.000	999999.000	1	s	Float	IM	T, U
	<p><b>Description:</b> Sets the ramp-down time for the ramp-function generator. The ramp-function generator ramps-down the speed setpoint from the maximum speed (p1082) down to standstill (setpoint = 0) in this time. Further, the ramp-down time is always effective for OFF1.</p> <p><b>Dependency:</b> Refer to p1082</p>							
p1130	Ramp-function generator initial rounding-off time	0.000	30.000	0.000	s	Float	IM	T, U
	<p><b>Description:</b> Sets the initial rounding-off time for the extended ramp generator. The value applies to ramp-up and ramp-down.</p> <p><b>Note:</b> Rounding-off times avoid an abrupt response and prevent damage to the mechanical system.</p>							
p1131	Ramp-function generator final rounding-off time	0.000	30.000	0.000	s	Float	IM	T, U
	<p><b>Description:</b> Sets the final rounding-off time for the extended ramp generator. The value applies to ramp-up and ramp-down.</p> <p><b>Note:</b> Rounding-off times avoid an abrupt response and prevent damage to the mechanical system.</p>							
p1215 *	Motor holding brake configuration	0	3	0	-	l16	IM	T
	<p><b>Description:</b> Sets the holding brake configuration.</p> <p><b>Dependency:</b> Refer to p1216, p1217, p1226, p1227, p1228</p> <p><b>Caution:</b> For the setting p1215 = 0, if a brake is used, it remains closed. If the motor moves, this will destroy the brake.</p> <p><b>Notice:</b> If p1215 was set to 1 or if p1215 was set to 3, then when the pulses are suppressed, the brake is closed even if the motor is still rotating.</p> <p><b>Note:</b> If a holding brake integrated in the motor is used, then it is not permissible that p1215 is set to 3. The parameter can only be set to zero when the pulses are inhibited.</p>							
p1216 *	Motor holding brake opening time	0	10000	100	ms	Float	IM	T, U
	<p><b>Description:</b> Sets the time to open the motor holding brake. After controlling the holding brake (opens), the speed/velocity setpoint remains at zero for this time. After this, the speed/velocity setpoint is enabled.</p> <p><b>Dependency:</b> Refer to p1215, p1217</p> <p><b>Note:</b> For a motor with integrated brake, this time is pre-assigned the value saved in the motor. For p1216 = 0 ms, the monitoring and the message A7931 "Brake does not open" are deactivated.</p>							
p1217 *	Motor holding brake closing time	0	10000	100	ms	Float	IM	T, U
	<p><b>Description:</b> Sets the time to apply the motor holding brake. After OFF1 or OFF3 and the holding brake is controlled (the brake closes), then the drive remains closed-loop controlled for this time stationary with a speed setpoint/velocity setpoint of zero. The pulses are suppressed when the time expires.</p> <p><b>Dependency:</b> Refer to p1215, p1216</p> <p><b>Note:</b> For a motor with integrated brake, this time is pre-assigned the value saved in the motor. For p1217 = 0 ms, the monitoring and the message A07932 "Brake does not close" are deactivated.</p>							

## 10.2 Parameter list

Par. No.	Name	Min	Max	Factory Setting	Unit	Data type	Effective	Can be changed
p1226	Threshold for zero speed detection	0.00	210000.00	20.00	rpm	Float	IM	T, U
<p><b>Description:</b> Sets the speed threshold for the standstill identification.</p> <p>Acts on the actual value and setpoint monitoring. When braking with OFF1 or OFF3, when the threshold is undershot, standstill is identified.</p> <p>The following applies when the brake control is activated:</p> <p>When the threshold is undershot, the brake control is started and the system waits for the brake closing time in p1217. The pulses are then suppressed.</p> <p>If the brake control is not activated, the following applies:</p> <p>When the threshold is undershot, the pulses are suppressed and the drive coasts down.</p>								
<p><b>Dependency:</b> Refer to p1215, p1216, p1217, p1227</p>								
<p><b>Notice:</b> For reasons relating to the compatibility to earlier firmware versions, a parameter value of zero in indices 1 to 31 is overwritten with the parameter value in index 0 when the drive boots.</p>								
<p><b>Note:</b> Standstill is identified in the following cases:</p> <ul style="list-style-type: none"> <li>- The speed actual value falls below the speed threshold in p1226 and the time started after this in p1228 has expired.</li> <li>- The speed setpoint falls below the speed threshold in p1226 and the time started after this in p1227 has expired.</li> </ul> <p>The actual value sensing is subject to measuring noise. For this reason, standstill cannot be detected if the speed threshold is too low.</p>								
p1227	Zero speed detection monitoring time	0.000	300.000	300.000	s	Float	IM	T, U
<p><b>Description:</b> Sets the monitoring time for the standstill identification.</p> <p>When braking with OFF1 or OFF3, standstill is identified after this time has expired, after the setpoint speed has fallen below p1226.</p> <p>After this, the brake control is started, the system waits for the closing time in p1217 and then the pulses are suppressed.</p>								
<p><b>Dependency:</b> Refer to p1215, p1216, p1217, p1226</p>								
<p><b>Notice:</b> The setpoint is not equal to zero dependent on the selected value. This can therefore cause the monitoring time in p1227 to be exceeded. In this case, for a driven motor, the pulses are not suppressed..</p>								
<p><b>Note:</b> Standstill is identified in the following cases:</p> <ul style="list-style-type: none"> <li>- The speed actual value falls below the speed threshold in p1226 and the time started after this in p1228 has expired.</li> <li>- The speed setpoint falls below the speed threshold in p1226 and the time started after this in p1227 has expired.</li> </ul> <p>For p1227 = 300.000 s, the following applies:</p> <p>Monitoring is de-activated.</p> <p>For p1227 = 0.000 s, the following applies:</p> <p>With OFF1 or OFF3 and a ramp-down time = 0, the pulses are immediately suppressed and the motor "coasts" down.</p>								

Par. No.	Name	Min	Max	Factory Setting	Unit	Data type	Effective	Can be changed
p1228	Pulse suppression delay time	0.000	299.000	0.000	s	Float	IM	T, U
	<b>Description:</b> Sets the delay time for pulse suppression. After OFF1 or OFF3, the pulses are canceled, if at least one of the following conditions is fulfilled: - The speed actual value falls below the threshold in p1226 and the time started after this in p1228 has expired. - The speed setpoint falls below the threshold in p1226 and the time started after this in p1227 has expired.							
	<b>Dependency:</b> Refer to p1226, p1227							
	<b>Notice:</b> When the motor holding brake is activated, pulse cancellation is additionally delayed by the brake closing time (p1217).							
p1414	Speed setpoint filter activation	0000 bin	0011 bin	0000 bin	-	U16	IM	T, U
	<b>Description:</b> Setting for activating/de-activating the speed setpoint filter.							
	<b>Dependency:</b> The individual speed setpoint filters are parameterized as of p1415.							
	<b>Note:</b> The drive unit displays the value in hex format. To know the logic (high/low) assignment to each bit, you must convert the hex number to the binary number, for example, FF (hex) = 11111111 (bin).							
p1415	Speed setpoint filter 1 type	0	2	0	-	l16	IM	T, U
	<b>Description:</b> Sets the type for speed setpoint filter 1.							
	<b>Dependency:</b> PT1 low pass: p1416 PT2 low pass: p1417, p1418 General filter: p1417 ... p1420							
p1416	Speed setpoint filter 1 time constant	0.00	5000.00	0.00	ms	Float	IM	T, U
	<b>Description:</b> Sets the time constant for the speed setpoint filter 1 (PT1).							
	<b>Dependency:</b> Refer to p1414, p1415							
	<b>Note:</b> This parameter is only effective if the filter is set as a PT1 low pass.							
p1417	Speed setpoint filter 1 denominator natural frequency	0.5	16000.0	1999.0	Hz	Float	IM	T, U
	<b>Description:</b> Sets the denominator natural frequency for speed setpoint filter 1 (PT2, general filter).							
	<b>Dependency:</b> Refer to p1414, p1415							
	<b>Note:</b> This parameter is only effective if the speed filter is parameterized as a PT2 low pass or as general filter. The filter is only effective if the natural frequency is less than half of the sampling frequency.							
p1418	Speed setpoint filter 1 denominator damping	0.001	10.000	0.700	-	Float	IM	T, U
	<b>Description:</b> Sets the denominator damping for speed setpoint filter 1 (PT2, general filter).							
	<b>Dependency:</b> Refer to p1414, p1415 <b>Note:</b> This parameter is only effective if the speed filter is parameterized as a PT2 low pass or as general filter.							

## 10.2 Parameter list

Par. No.	Name	Min	Max	Factory Setting	Unit	Data type	Effective	Can be changed
p1419	Speed setpoint filter 1 numerator natural frequency	0.5	16000.0	1999.0	Hz	Float	IM	T, U
	<b>Description:</b> Sets the numerator natural frequency for speed setpoint filter 1 (general filter).							
	<b>Dependency:</b> Refer to p1414, p1415							
	<b>Note:</b> This parameter is only effective if the speed filter is set as a general filter. The filter is only effective if the natural frequency is less than half of the sampling frequency.							
p1420	Speed setpoint filter 1 numerator damping	0.001	10.000	0.700	-	Float	IM	T, U
	<b>Description:</b> Sets the numerator damping for speed setpoint filter 1 (general filter).							
	<b>Dependency:</b> Refer to p1414, p1415							
	<b>Note:</b> This parameter is only effective if the speed filter is set as a general filter.							
p1421	Speed setpoint filter 2 type	0	2	0	-	I16	IM	T, U
	<b>Description:</b> Sets the type for speed setpoint filter 2.							
	<b>Dependency:</b> PT1 low pass: p1422 PT2 low pass: p1423, p1424 General filter: p1423 ... p1426							
p1422	Speed setpoint filter 2 time constant	0.00	5000.00	0.00	ms	Float	IM	T, U
	<b>Description:</b> Sets the time constant for the speed setpoint filter 2 (PT1).							
	<b>Dependency:</b> Refer to p1414, p1421							
	<b>Note:</b> This parameter is only effective if the speed filter is set as a PT1 low pass.							
p1423	Speed setpoint filter 2 denominator natural frequency	0.5	16000.0	1999.0	Hz	Float	IM	T, U
	<b>Description:</b> Sets the denominator natural frequency for speed setpoint filter 2 (PT2, general filter).							
	<b>Dependency:</b> Refer to p1414, p1421							
	<b>Note:</b> This parameter is only effective if the speed filter is parameterized as a PT2 low pass or as general filter. The filter is only effective if the natural frequency is less than half of the sampling frequency.							
p1424	Speed setpoint filter 2 denominator damping	0.001	10.000	0.700	-	Float	IM	T, U
	<b>Description:</b> Sets the denominator damping for speed setpoint filter 2 (PT2, general filter).							
	<b>Dependency:</b> Refer to p1414, p1421							
	<b>Note:</b> This parameter is only effective if the speed filter is parameterized as a PT2 low pass or as general filter.							
p1425	Speed setpoint filter 2 numerator natural frequency	0.5	16000.0	1999.0	Hz	Float	IM	T, U
	<b>Description:</b> Sets the numerator natural frequency for speed setpoint filter 2 (general filter).							
	<b>Dependency:</b> Refer to p1414, p1421							
	<b>Note:</b> This parameter is only effective if the speed filter is set as a general filter. The filter is only effective if the natural frequency is less than half of the sampling frequency.							

Par. No.	Name	Min	Max	Factory Setting	Unit	Data type	Effective	Can be changed
p1426	Speed setpoint filter 2 numerator damping	0.000	10.000	0.700	-	Float	IM	T, U
	<b>Description:</b> Sets the numerator damping for speed setpoint filter 2 (general filter).							
	<b>Dependency:</b> Refer to p1414, p1421							
	<b>Note:</b> This parameter is only effective if the speed filter is set as a general filter.							
p1441	Actual speed smoothing time	0.00	50.00	0.00	ms	Float	IM	T, U
	<b>Description:</b> Sets the smoothing time constant (PT1) for the speed actual value.							
	<b>Note:</b> The speed actual value should be smoothed for increment encoders with a low pulse number. After this parameter has been changed, we recommend that the speed controller is adapted and/or the speed controller settings checked Kp (p29120) and Tn (p29121).							
p1520 *	Torque limit upper	-1000000.00	2000000.00	0.00	Nm	Float	IM	T, U
	<b>Description:</b> Sets the fixed upper torque limit.							
	<b>Danger:</b> Negative values when setting the upper torque limit (p1520 < 0) can result in the motor accelerating in an uncontrollable fashion.							
	<b>Notice:</b> The maximum value depends on the maximum torque of the connected motor.							
p1521 *	Torque limit lower	-2000000.00	1000000.00	0.00	Nm	Float	IM	T, U
	<b>Description:</b> Sets the fixed lower torque limit.							
	<b>Danger:</b> Positive values when setting the lower torque limit (p1521 > 0) can result in the motor accelerating in an uncontrollable fashion.							
	<b>Notice:</b> The maximum value depends on the maximum torque of the connected motor.							
p1656 *	Activates current setpoint filter	0000 bin	1111 bin	0001 bin	-	U16	IM	T, U
	<b>Description:</b> Setting for activating/de-activating the current setpoint filter.							
	<b>Dependency:</b> The individual current setpoint filters are parameterized as of p1658.							
	<b>Note:</b> If not all of the filters are required, then the filters should be used consecutively starting from filter 1. The drive unit displays the value in hex format. To know the logic (high/low) assignment to each bit, you must convert the hex number to the binary number, for example, FF (hex) = 11111111 (bin).							
p1658 *	Current setpoint filter 1 denominator natural frequency	0.5	16000.0	1999.0	Hz	Float	IM	T, U
	<b>Description:</b> Sets the denominator natural frequency for current setpoint filter 1 (PT2, general filter).							
	<b>Dependency:</b> The current setpoint filter 1 is activated via p1656.0 and parameterized via p1658 ... p1659.							
p1659 *	Current setpoint filter 1 denominator damping	0.001	10.000	0.700	-	Float	IM	T, U
	<b>Description:</b> Sets the denominator damping for current setpoint filter 1.							
	<b>Dependency:</b> The current setpoint filter 1 is activated via p1656.0 and parameterized via p1658 ... p1659.							
p1663	Current setpoint filter 2 denominator natural frequency	0.5	16000.0	1000.0	Hz	Float	IM	T, U
	<b>Description:</b> Sets the denominator natural frequency for current setpoint filter 2 (PT2, general filter).							
	<b>Dependency:</b> Current setpoint filter 2 is activated via p1656.1 and parameterized via p1663 ... p1666.							

## 10.2 Parameter list

Par. No.	Name	Min	Max	Factory Setting	Unit	Data type	Effective	Can be changed
p1664	Current setpoint filter 2 denominator damping	0.001	10.000	0.300	-	Float	IM	T, U
	<b>Description:</b> Sets the denominator damping for current setpoint filter 2.							
	<b>Dependency:</b> Current setpoint filter 2 is activated via p1656.1 and parameterized via p1663 ... p1666.							
p1665	Current setpoint filter 2 numerator natural frequency	0.5	16000.0	1000.0	Hz	Float	IM	T, U
	<b>Description:</b> Sets the numerator natural frequency for current setpoint filter 2 (general filter).							
	<b>Dependency:</b> Current setpoint filter 2 is activated via p1656.1 and parameterized via p1662 ... p1666.							
p1666	Current setpoint filter 2 numerator damping	0.000	10.000	0.010	-	Float	IM	T, U
	<b>Description:</b> Sets the numerator damping for current setpoint filter 2.							
	<b>Dependency:</b> Current setpoint filter 2 is activated via p1656.1 and parameterized via p1663 ... p1666.							
p1668	Current setpoint filter 3 denominator natural frequency	0.5	16000.0	1000.0	Hz	Float	IM	T, U
	<b>Description:</b> Sets the denominator natural frequency for current setpoint filter 3 (PT2, general filter).							
	<b>Dependency:</b> Current setpoint filter 3 is activated via p1656.2 and parameterized via p1668 ... p1671.							
p1669	Current setpoint filter 3 denominator damping	0.001	10.000	0.300	-	Float	IM	T, U
	<b>Description:</b> Sets the denominator damping for current setpoint filter 3.							
	<b>Dependency:</b> Current setpoint filter 3 is activated via p1656.2 and parameterized via p1668 ... p1671.							
p1670	Current setpoint filter 3 numerator natural frequency	0.5	16000.0	1000.0	Hz	Float	IM	T, U
	<b>Description:</b> Sets the numerator natural frequency for current setpoint filter 3 (general filter).							
	<b>Dependency:</b> Current setpoint filter 3 is activated via p1656.2 and parameterized via p1668 ... p1671.							
p1671	Current setpoint filter 3 numerator damping	0.000	10.000	0.010	-	Float	IM	T, U
	<b>Description:</b> Sets the numerator damping for current setpoint filter 3.							
	<b>Dependency:</b> Current setpoint filter 3 is activated via p1656.2 and parameterized via p1668 ... p1671.							
p1673	Current setpoint filter 4 denominator natural frequency	0.5	16000.0	1000.0	Hz	Float	IM	T, U
	<b>Description:</b> Sets the denominator natural frequency for current setpoint filter 4 (PT2, general filter).							
	<b>Dependency:</b> Current setpoint filter 4 is activated via p1656.3 and parameterized via p1673 ... p1675.							
p1674	Current setpoint filter 4 denominator damping	0.001	10.000	0.300	-	Float	IM	T, U
	<b>Description:</b> Sets the denominator damping for current setpoint filter 4.							
	<b>Dependency:</b> Current setpoint filter 4 is activated via p1656.3 and parameterized via p1673 ... p1675.							
p1675	Current setpoint filter 4 numerator natural frequency	0.5	16000.0	1000.0	Hz	Float	IM	T, U
	<b>Description:</b> Sets the numerator natural frequency for current setpoint filter 4 (general filter).							
	<b>Dependency:</b> Current setpoint filter 4 is activated via p1656.3 and parameterized via p1673 ... p1675.							

Par. No.	Name	Min	Max	Factory Setting	Unit	Data type	Effective	Can be changed
p1676	Current setpoint filter 4 numerator damping	0.000	10.000	0.010	-	Float	IM	T, U
	<b>Description:</b> Sets the numerator damping for current setpoint filter 4.							
	<b>Dependency:</b> Current setpoint filter 4 is activated via p1656.3 and parameterized via p1673 ... p1675.							
p2153	Speed actual value filter time constant	0	1000000	0	ms	Float	IM	T, U
	<b>Description:</b> Sets the time constant of the PT1 element to smooth the speed/velocity actual value. The smoothed actual speed/velocity is compared with the threshold values and is only used for messages and signals.							
p2161 *	Speed threshold 3	0.00	210000.00	10.00	rpm	Float	IM	T, U
	<b>Description:</b> Sets the speed threshold value for the signal that indicates the axis is stationary.							
p2162 *	Hysteresis speed n_act > n_max	0.00	60000.00	0.00	rpm	Float	IM	T, U
	<b>Description:</b> Sets the hysteresis speed (bandwidth) for the signal "n_act > n_max".							
	<b>Note:</b> For a negative speed limit, the hysteresis is effective below the limit value and for a positive speed limit above the limit value. If significant overshoot occurs in the maximum speed range (for example, due to load shedding), you are advised to increase the dynamic response of the speed controller (if possible). If this is insufficient, the hysteresis p2162 can be increased, but its value must not be greater than the value calculated by the formula below when the motor maximum speed is sufficiently greater than the maximum speed p1082. $p2162 \leq 1.05 \times \text{motor maximum speed} - \text{maximum speed (p1082)}$ The range of the parameter is different when connect with different motors.							
p2175 *	Motor blocked speed threshold	0.00	210000.00	210000.00	rpm	Float	IM	T, U
	<b>Description:</b> Sets the speed threshold for the message "Motor blocked".							
	<b>Dependency:</b> Refer to p2177.							
p2177 *	Motor blocked delay time	0.000	65.000	0.500	s	Float	IM	T, U
	<b>Description:</b> Sets the delay time for the message "Motor blocked".							
	<b>Dependency:</b> Refer to p2175.							
p2525	LR encoder adjustment offset	0	4294967295	0	LU	U32	IM	T
	<b>Description:</b> For the absolute encoder adjustment, a drive determines the position offset.							
	<b>Note:</b> The position offset is only relevant for absolute encoders. The drive determines it when making the adjustment and the user should not change it.							
p2533	LR position setpoint filter time constant	0.00	1000.00	0.00	ms	Float	IM	T, U
	<b>Description:</b> Sets the time constant for the position setpoint filter (PT1).							
	<b>Note:</b> The effective Kv factor (position loop gain) is reduced with the filter. This allows a softer control behavior with improved tolerance with respect to noise/disturbances. Applications: - Reduces the pre-control dynamic response. - Jerk limiting.							

Par. No.	Name	Min	Max	Factory Setting	Unit	Data type	Effective	Can be changed
p2542 *	LR standstill window	0	214748364 7	1000	LU	U32	IM	T, U
	<p><b>Description:</b> Sets the standstill window for the standstill monitoring function. After the standstill monitoring time expires, it is cyclically checked whether the difference between the setpoint and actual position is located within the standstill window and, if required, an appropriate fault is output. Value = 0: The standstill monitoring is deactivated.</p>							
	<p><b>Dependency:</b> Refer to: p2543, p2544, and F07450</p>							
	<p><b>Note:</b> The following applies for the setting of the standstill and positioning window: Standstill window (p2542) ≥ positioning window (p2544)</p>							
p2543 *	LR standstill monitoring time	0.00	100000.00	200.00	ms	Float	IM	T, U
	<p><b>Description:</b> Sets the standstill monitoring time for the standstill monitoring function. After the standstill monitoring time expires, it is cyclically checked whether the difference between the setpoint and actual position is located within the standstill window and, if required, an appropriate fault is output.</p>							
	<p><b>Dependency:</b> Refer to: p2542, p2545, and F07450</p>							
	<p><b>Note:</b> The following applies for the setting of the standstill and positioning monitoring time: Standstill monitoring time (p2543) ≤ positioning monitoring time (p2545)</p>							
p2544 *	LR positioning window	0	214748364 7	40	LU	U32	IM	T, U
	<p><b>Description:</b> Sets the positioning window for the positioning monitoring function. After the positioning monitoring time expires, it is checked once as to whether the difference between the setpoint and actual position lies within the positioning window and if required an appropriate fault is output. Value = 0: The positioning monitoring function is de-activated.</p>							
	<p><b>Dependency:</b> Refer to F07451.</p>							
	<p><b>Note:</b> The following applies for the setting of the standstill and positioning window: Standstill window (p2542) ≥ positioning window (p2544)</p>							
p2545 *	LR positioning monitoring time	0.00	100000.00	1000.00	ms	Float	IM	T, U
	<p><b>Description:</b> Sets the positioning monitoring time for the positioning monitoring. After the positioning monitoring time expires, it is checked once as to whether the difference between the setpoint and actual position lies within the positioning window and if required an appropriate fault is output.</p>							
	<p><b>Dependency:</b> The range of p2545 depends on p2543. Refer to: p2543, p2544, and F07451</p>							
	<p><b>Note:</b> The tolerance bandwidth is intended to prevent the dynamic following error monitoring incorrectly responding due to operational control sequences (for example, during load surges).</p>							
p2546 *	LR dynamic following error monitoring tolerance	0	214748364 7	3000/62 9146	LU	U32	IM	T, U
	<p><b>Description:</b> Sets the tolerance for the dynamic following error monitoring. If the dynamic following error (r2563) exceeds the selected tolerance, then an appropriate fault is output. For a motor with an incremental encoder, the default value is 3000. For a motor with an absolute encoder, the default value is 629146. Value = 0: The dynamic following error monitoring is deactivated.</p>							
	<p><b>Dependency:</b> Refer to r2563, F07452</p>							
	<p><b>Note:</b> The tolerance bandwidth is intended to prevent the dynamic following error monitoring incorrectly responding due to operational control sequences (e.g. during load surges).</p>							



Par. No.	Name	Min	Max	Factory Setting	Unit	Data type	Effective	Can be changed
p2571	IPos maximum velocity	1	40000000	30000	100 0 LU/ min	U32	IM	T, U
	<b>Description:</b> Sets the maximum velocity for the "basic positioner" function (IPos).							
	<b>Note:</b> The maximum velocity is active in all of the operating modes of the basic positioner. The maximum velocity for the basic positioner should be aligned with the maximum speed/velocity of the speed/velocity controller.							
p2572 **	IPos maximum acceleration	1	2000000	Motor de- pendent	100 0 LU/s <sup>2</sup>	U32	IM	T
	<b>Description:</b> Sets the maximum acceleration for the "basic positioner" function (IPos).							
	<b>Note:</b> The maximum acceleration appears to exhibit jumps (without jerk). "Traversing blocks" operating mode: The programmed acceleration override acts on the maximum acceleration. "Direct setpoint input/MDI" mode: The acceleration override is effective. "Jog" and "search for reference" modes: No acceleration override is active. The axis starts with the maximum acceleration.							
p2573 **	IPos maximum deceleration	1	2000000	Motor de- pendent	100 0 LU/s <sup>2</sup>	U32	IM	T
	<b>Description:</b> Sets the maximum deceleration for the "basic positioner" function (IPos).							
	<b>Note:</b> The maximum deceleration appears to exhibit jumps (without jerk). "Traversing blocks" operating mode: The programmed deceleration override acts on the maximum deceleration. "Direct setpoint input/MDI" mode: The deceleration override is effective. "Jog" and "search for reference" modes: No deceleration override is effective. The axis brakes with the maximum deceleration.							
p2574 **	IPos jerk limiting	1	100000000	10000	100 0 LU/s <sup>3</sup>	U32	IM	T, U
	<b>Description:</b> Sets the jerk limiting.							
	<b>Dependency:</b> Refer to p2572, p2573, and p2575							
	<b>Note:</b> The jerk limiting is internally converted into a jerk time as follows: Jerk time $T_r = \max(p2572, p2573)/p2574$							
p2575	IPos jerk limiting activation	0	1	0	-	U32	IM	T
	<b>Description:</b> Activates the jerk limiting.							
	<ul style="list-style-type: none"> <li>• 0: The jerk limiting is deactivated.</li> <li>• 1: The jerk limiting is activated.</li> </ul>							
<b>Dependency:</b> Refer to p2574								

Par. No.	Name	Min	Max	Factory Setting	Unit	Data type	Effective	Can be changed
p2580	EPOS software limit switch minus	-2147482648	2147482647	-2147482648	LU	I32	IM	T, U
	<b>Description:</b> Sets the software limit switch in the negative direction of travel.							
	<b>Dependency:</b> Refer to p2581, p2582							
p2581	EPOS software limit switch plus	-2147482648	2147482647	2147482647	LU	I32	IM	T, U
	<b>Description:</b> Sets the software limit switch in the positive direction of travel.							
	<b>Dependency:</b> Refer to p2580, p2582							
p2582	EPOS software limit switch activation	-	-	0	-	U32/Binary	IM	T
	<b>Description:</b> Sets the signal source to activate the "software limit switch".							
	<b>Dependency:</b> Refer to p2580, p2581							
	<b>Caution:</b> Software limit switch effective: - Axis is referenced. Software limit switch ineffective: - Modulo correction active. - Search for reference is executed.							
	<b>Notice:</b> Target position for relative positioning outside software limit switch: The traversing block is started and the axis comes to a standstill at the software limit switch. An appropriate alarm is output and the traversing block is interrupted. Traversing blocks with valid position can be activated. Target position for absolute positioning outside software limit switch: In the "traversing blocks" mode, the traversing block is not started and an appropriate fault is output. Axis outside the valid traversing range: If the axis is already outside the valid traversing range, then an appropriate fault is output. The fault can be acknowledged at standstill. Traversing blocks with valid position can be activated.							
	<b>Note:</b> The traversing range can also be limited using STOP cams.							
p2583	EPOS backlash compensation	-200000	200000	0	LU	I32	IM	T, U
	<b>Description:</b> Sets the amount of play (backlash) for positive or negative play. <ul style="list-style-type: none"> <li>= 0: The backlash compensation is deactivated.</li> <li>&gt; 0: Positive backlash (normal case)</li> </ul> When the direction is reversed, the encoder actual value leads the actual value. <ul style="list-style-type: none"> <li>&lt; 0: Negative backlash</li> </ul> When the direction is reversed, the actual value leads the encoder actual value.							
	<b>Dependency:</b> If a stationary axis is referenced by setting the reference point, or an adjusted with absolute encoder is powered up, then the setting of p2604 is relevant for entering the compensation value. p2604 = 1: Traveling in the positive direction -> A compensation value is immediately entered. Traveling in the negative direction -> A compensation value is not entered p2604 = 0: Traveling in the positive direction -> A compensation value is not entered Traveling in the negative direction -> A compensation value is immediately entered. When again setting the reference point (a referenced axis) or for "flying referencing", p2604 is not relevant but instead the history of the axis. Refer to: p2604							

Par. No.	Name	Min	Max	Factory Setting	Unit	Data type	Effective	Can be changed
p2599	EPOS reference point coordinate value	-2147482648	2147482647	0	LU	I32	IM	T, U
	<p><b>Description:</b> Sets the position value for the reference point coordinate. This value is set as the actual axis position after referencing or adjustment.</p> <p><b>Dependency:</b> Refer to p2525</p>							
p2600	EPOS search for reference point offset	-2147482648	2147482647	0	LU	I32	IM	T, U
	<p><b>Description:</b> Sets the reference point offset for search for reference.</p>							
p2604	EPOS search for reference start direction	-	-	0	-	U32/Binary	IM	T
	<p><b>Description:</b> Sets the signal sources for the start direction of the search for reference.</p> <ul style="list-style-type: none"> <li>• 1 signal: Start in the negative direction.</li> <li>• 0 signal: Start in the positive direction.</li> </ul>							
	<p><b>Dependency:</b> Refer to p2583</p>							
p2605	EPOS search for reference approach velocity reference cam	1	40000000	5000	100 0 LU/ min	U32	IM	T, U
	<p><b>Description:</b> Sets the approach velocity to the reference cam for the search for reference.</p>							
	<p><b>Dependency:</b> The search for reference only starts with the approach velocity to the reference cam when there is a reference cam. Refer to p2604, p2606</p>							
	<p><b>Note:</b> When traversing to the reference cam, the velocity override is effective. If, at the start of the search for reference, the axis is already at the reference cam, then the axis immediately starts to traverse to the zero mark.</p>							
p2606	EPOS search for reference reference cam maximum distance	0	2147482647	2147482647	LU	U32	IM	T, U
	<p><b>Description:</b> Sets the maximum distance after the start of the search for reference when traversing to the reference cam.</p>							
	<p><b>Dependency:</b> Refer to p2604, p2605, F07458</p> <p><b>Note:</b> When using a reversing cam, the maximum distance must be set appropriately long.</p>							
p2608	EPOS search for reference approach velocity zero mark	1	40000000	300	100 0 LU/ min	U32	IM	T, U
	<p><b>Description:</b> Sets the approach velocity after detecting the reference cam to search for the zero mark for the search for reference.</p>							
	<p><b>Dependency:</b> If there is no reference cam, the search for reference immediately starts with the axis traversing to the zero mark. Refer to p2604, p2609</p>							
	<p><b>Caution:</b> If the reference cam is not adjusted so that at each search for reference the same zero mark for synchronization is detected, then an "incorrect" axis reference point is obtained. After the reference cam has been left, the search for the zero mark is activated with a time delay due to internal factors. This is the reason that the reference cam should be adjusted in this center between two zero marks and the approach velocity should be adapted to the distance between two zero marks.</p> <p><b>Note:</b> The velocity override is not effective when traversing to the zero mark.</p>							

## 10.2 Parameter list

Par. No.	Name	Min	Max	Factory Setting	Unit	Data type	Effective	Can be changed
p2609	EPOS search for reference max. distance ref. cam and zero mark	0	2147482647	20000	LU	U32	IM	T, U
	<b>Description:</b> Sets the maximum distance after leaving the reference cam when traversing to the zero mark.							
	<b>Dependency:</b> Refer to p2604, p2608, F07459							
p2611	EPOS search for reference approach velocity reference point	1	40000000	300	1000 LU/min	U32	IM	T, U
	<b>Description:</b> Sets the approach velocity after detecting the zero mark to approach the reference point.							
	<b>Dependency:</b> Refer to p2604, p2609							
<b>Note:</b> When traversing to the reference point, the velocity override is not effective.								
p2617[0...7]	EPOS traversing block position	-2147482648	2147482647	0	LU	I32	IM	T, U
	<b>Description:</b> Sets the target position for the traversing block.							
	<b>Dependency:</b> Refer to p2618							
<b>Note:</b> The target position is approached in either relative or absolute terms depending on p29241.								
p2618[0...7]	EPOS traversing block velocity	1	40000000	600	1000 LU/min	I32	IM	T, U
	<b>Description:</b> Sets the velocity for the traversing block.							
	<b>Dependency:</b> Refer to p2617							
<b>Note:</b> The velocity can be influenced using the velocity override.								
p2621[0...7]	Internal positioning task	1	2	1	-	I16	IM	T, U
	<b>Description:</b> Sets the required task for the traversing block.							
	<ul style="list-style-type: none"> <li>• 1: POSITIONING</li> <li>• 2: FIXED STOP</li> </ul>							
<b>Dependency:</b> Refer to: p2617, p2618								
p2634 *	Fixed stop maximum following error	0	2147482647	1000	LU	U32	IM	T, U
	<b>Description:</b> Sets the following error to detect the "fixed stop reached" state.							
	<b>Dependency:</b> Refer to: p2621							
<b>Note:</b> The state "fixed stop reached" is detected if the following error exceeds the theoretically calculated following error value by p2634.								
p2635 *	Fixed stop monitoring window	0	2147482647	100	LU	U32	IM	T, U
	<b>Description:</b> Sets the monitoring window of the actual position after the fixed stop is reached.							
	<b>Dependency:</b> Refer to: F07484							
<b>Note:</b> If, after the fixed stop is reached, the end stop shifts in either the positive or negative direction by more than the value set here, an appropriate message is output.								
p2692	MDI acceleration override, fixed setpoint	0.100	100.000	100.000	%	Float	IM	T, U
	<b>Description:</b> Sets a fixed setpoint for the acceleration override.							
	<b>Note:</b> The percentage value refers to the maximum acceleration (p2572).							

Par. No.	Name	Min	Max	Factory Setting	Unit	Data type	Effective	Can be changed
p2693	MDI deceleration override, fixed setpoint	0.100	100.000	100.000	%	Float	IM	T, U
	<b>Description:</b> Sets a fixed setpoint for the deceleration override.							
	<b>Note:</b> The percentage value refers to the maximum deceleration (p2573).							
p29000 *	Motor ID	0	65535	0	-	U16	IM	T
	<b>Description:</b> Motor type number is printed on the motor rating plate as motor ID. For a motor with an incremental encoder, users need to manually input the parameter value. For a motor with an absolute encoder, the drive automatically reads the parameter value.							
p29001	Reversal of motor direction	0	1	0	-	I16	IM	T
	<b>Description:</b> Reversal of motor running direction. By default, CW is the positive direction while CCW the negative direction. After changing of p29001, reference point will lost, A7461 will remind user to referencing again.							
	<ul style="list-style-type: none"> <li>• 0: No reversal</li> <li>• 1: Reverse</li> </ul>							
p29002	BOP display selection	0	4	0	-	I16	IM	T, U
	<b>Description:</b> Selection of BOP operating display.							
	<ul style="list-style-type: none"> <li>• 0: Actual speed (default)</li> <li>• 1: DC voltage</li> <li>• 2: Actual torque</li> <li>• 3: Actual position</li> <li>• 4: Position following error</li> </ul>							
p29003	Control mode	0	8	0	-	I16	RE	T
	<b>Description:</b> Selection of control mode.							
	<ul style="list-style-type: none"> <li>• 0: Position control with pulse train input (PTI)</li> <li>• 1: Internal position control (IPos)</li> <li>• 2: Speed control (S)</li> <li>• 3: Torque control (T)</li> <li>• 4: Control change mode: PTI/S</li> <li>• 5: Control change mode: IPos/S</li> <li>• 6: Control change mode: PTI/T</li> <li>• 7: Control change mode: IPos/T</li> <li>• 8: Control change mode: S/T</li> </ul>							
<b>Note:</b> The compound control mode can be controlled by the digital input signal C-MODE. When DI10 (C-MODE) is 0, the first control mode of control change mode is selected; otherwise, the second one is selected.								
p29004	RS485 address	1	31	1	-	U16	RE	T
	<b>Description:</b> Configuration of the RS485 bus address. The RS485 bus is used to transfer current absolute position of the servo drive to the controller/PLC.							
	<b>Note:</b> Changes only become effective after power on. The parameter isn't influenced by default function.							
p29005	Braking resistor capacity percentage alarm threshold	1	100	100	%	Float	IM	T
	<b>Description:</b> Alarm triggering threshold for the capacity of the internal braking resistor.							
	Alarm number: A52901							

Par. No.	Name	Min	Max	Factory Setting	Unit	Data type	Effective	Can be changed
p29006	Line supply voltage	200	480	400/230	V	U16	IM	T
	<p><b>Description:</b> Nominal Line supply voltage, effective value of line to line voltage. Drive can operate within -15% to +10% error.</p> <p>For V90 400 V variant, the value range is 380 V to 480 V, default value is 400 V.</p> <p>For V90 200 V variant, the value range is 200 V to 240 V, default value is 230 V.</p>							
p29007	RS485 protocol	0	2	1	-	I16	RE	T
	<p><b>Description:</b> Set the communication protocol for the field bus interface:</p> <ul style="list-style-type: none"> <li>0: No protocol</li> <li>1: USS</li> <li>2: Modbus</li> </ul>							
	<p><b>Note:</b> Changes only become effective after power on. The parameter isn't influenced by default function.</p>							
p29008	Modbus control source	1	2	2	-	I16	RE	T
	<p><b>Description:</b> Select the Modbus control source:</p> <ul style="list-style-type: none"> <li>1: Setpoint and control word from Modbus PZD</li> <li>2: No control word <ul style="list-style-type: none"> <li>No setpoint and control word from Modbus PZD</li> </ul> </li> </ul>							
	<p><b>Note:</b> Changes only become effective after power on.</p>							
p29009	RS485 baud rate	5	13	8	-	I16	RE	T
	<p><b>Description:</b> Set the baud rate for the RS485 interface:</p> <ul style="list-style-type: none"> <li>5: 4800 baud</li> <li>6: 9600 baud</li> <li>7: 19200 baud</li> <li>8: 38400 baud</li> <li>9: 57600 baud</li> <li>10: 76800 baud</li> <li>11: 93750 baud</li> <li>12: 115200 baud</li> <li>13: 187500 baud</li> </ul>							
	<p><b>Note:</b> The change only becomes effective after power on. The parameter is not influenced by default function.</p>							
p29010	PTI: Selection of input pulse form	0	3	0	-	U16	IM	T
	<p><b>Description:</b> Selection of setpoint pulse train input form. After changing of p29010, reference point will lost, A7461 will remind user to referencing again.</p> <ul style="list-style-type: none"> <li>0: Pulse + direction, positive logic</li> <li>1: AB phase, positive logic</li> <li>2: Pulse + direction, negative logic</li> <li>3: AB phase, negative logic</li> </ul>							
p29011	PTI: Number of setpoint pulse per revolution	0	16777215	0	-	U32	IM	T
	<p><b>Description:</b> The number of setpoint pulses per motor revolution. The servo motor rotates for one revolution when the number of the setpoint pulses reaches this value.</p> <p>When this value is 0, the number of required setpoint pulses is decided by the electronic gear ratio.</p>							

Par. No.	Name	Min	Max	Factory Setting	Unit	Data type	Effective	Can be changed
p29012[0..3]	PTI: Numerator of electronic gear	1	10000	1	-	U32	IM	T
	<p><b>Description:</b> The numerator of the electronic gear ratio for the setpoint pulses. For the servo system with an absolute encoder, the value range of p29012 is 1 to 10000.</p> <p>Four numerators in total are available. You can select one of the numerators by configuring the digital input signal EGEAR.</p> <p>For detailed information about the calculation of a numerator, refer to the SINAMICS V90 Operating Instructions or use SINAMICS V-ASSISTANT to do the calculation.</p>							
p29013	PTI: Denominator of electronic gear	1	10000	1	-	U32	IM	T
	<p><b>Description:</b> The denominator of the electronic gear for the setpoint pulses.</p>							
p29014	PTI: Selection of pulse input electrical level	0	1	1	-	I16	IM	T
	<p><b>Description:</b> Selection of a logic level for the setpoint pulses.</p> <ul style="list-style-type: none"> <li>0: 5 V</li> <li>1: 24 V</li> </ul>							
p29016	PTI: Pulse input filter	0	1	[0] 0	-	I16	IM	T
	<p><b>Description:</b> Select filter for PTI input to get better EMC performance, 0 for low frequency PTI input, 1 for high frequency PTI input.</p>							
p29019	RS485 monitor time	0	1999999	0	ms	Float	IM	T, U
	<p><b>Description:</b> Sets the monitoring time to monitor the process data received via the RS485 bus interface. If no process data is received within this time, then an appropriate message is output.</p>							
	<p><b>Note:</b> If p29019 = 0, monitoring is deactivated.</p>							
p29020[0..1]	Tuning: Dynamic factor	1	35	18	-	U16	IM	T, U
	<p><b>Description:</b> The dynamic factor of auto tuning. 35 dynamic factors in total are available.</p>							
	<p>Index:</p> <ul style="list-style-type: none"> <li>[0]: Dynamic factor for one-button auto tuning</li> <li>[1]: Dynamic factor for real-time auto tuning</li> </ul>							
p29021	Tuning: Mode selection	0	5	0	-	I16	IM	T
	<p><b>Description:</b> Selection of a tuning mode.</p> <ul style="list-style-type: none"> <li>0: Disabled</li> <li>1: One-button auto tuning</li> <li>3: Real-time auto tuning</li> <li>5: Disable with default controller parameters</li> </ul>							
p29022	Tuning: Ratio of total inertia moment to motor inertia moment	1.00	10000.00	1.00	-	Float	IM	T, U
	<p><b>Description:</b> Ratio of total inertia moment to servo motor inertia moment.</p>							

Par. No.	Name	Min	Max	Factory Setting	Unit	Data type	Effective	Can be changed
p29023	Tuning: One-button auto tuning configuration	0	0xffff	0x0007	-	U16	IM	T
	<p><b>Description:</b> One-button auto tuning configuration.</p> <ul style="list-style-type: none"> <li>• Bit 0: The speed controller gain is determined and set using a noise signal.</li> <li>• Bit 1: Possible required current setpoint filters are determined and set using a noise signal. As a consequence, a higher dynamic performance can be achieved in the speed control loop.</li> <li>• Bit 2: The inertia moment ratio (p29022) can be measured after this function is running. If not set, the inertia moment ratio must be set manually with p29022.</li> <li>• Bit 7: With this bit set, multi-axes are adapted to the dynamic response set in p29028. This is necessary for interpolating axes. The time in p29028 should be set according to the axis with the lowest dynamic response.</li> </ul>							
p29024	Tuning: Real-time auto tuning configuration	0	0xffff	0x004c	-	U16	IM	T
	<p><b>Description:</b> Real-time auto tuning configuration.</p> <ul style="list-style-type: none"> <li>• Bit 2: The inertia moment ratio (p29022) is estimated while the motor is running, if not set, the inertia moment ratio must be set manually with p29022.</li> <li>• Bit 3: If not set, the inertia moment ratio (p29022) is estimated only once and the inertia estimator is deactivated automatically after the estimation is completed. If the bit is set to 1, the inertia moment ratio is estimated in real time and the controller adapts the parameters continuously. You are recommended to save the parameters when the estimation result is satisfied. After that, when you power on the drive next time, the controller will be started with the optimized parameters.</li> <li>• Bit 6: The adaption of current setpoint filter. This adaption may be necessary if a mechanical resonance frequency changes in operation. It can also be used to dampen a fixed resonance frequency. Once the control loop has stabilized, this bit should be deactivated and to save parameters in a non-volatile memory.</li> <li>• Bit 7: With this bit set, multi-axes are adapted to the dynamic response set in p29028. This is necessary for interpolating axes. The time in p29028 should be set according to the axis with the lowest dynamic response.</li> </ul>							
p29025	Tuning: Configuration overall	0	0x003f	0x0004	-	U16	IM	T
	<p><b>Description:</b> Overall configuration of auto tuning, apply for both one-button and real-time auto tuning.</p> <ul style="list-style-type: none"> <li>• Bit 0: For significant differences between the motor and load moment of inertia, or for low dynamic performance of the controller, then the P controller becomes a PD controller in the position control loop. As a consequence, the dynamic performance of the position controller is increased. This function should only be set when the speed pre-control (bit 3 = 1) or the torque pre-control (bit 4 = 1) is active.</li> <li>• Bit 1: At low speeds, the controller gain factors are automatically reduced in order to avoid noise and oscillation at standstill. This setting is recommended for incremental encoders.</li> <li>• Bit 2: The estimated load moment of inertia is taken into account for the speed controller gain.</li> <li>• Bit 3: Activates the speed pre-control for the position controller.</li> <li>• Bit 4: Activates the torque pre-control for the position controller.</li> <li>• Bit 5: Adapts acceleration limit.</li> </ul>							



Par. No.	Name	Min	Max	Factory Setting	Unit	Data type	Effective	Can be changed
	Note: <b>Speed pre-control</b> <ul style="list-style-type: none"> <li>The bit 3 of the p29025 will be set to 1 automatically after the factory default.</li> <li>You can set the bit 3 of p29025 manually in all control modes.</li> </ul> <b>Torque pre-control</b> <ul style="list-style-type: none"> <li>The bit 4 of p29025 will be set to 1 automatically if the following conditions are fulfilled simultaneously:               <ul style="list-style-type: none"> <li>Working with the 200 V drives</li> <li>Working in S control mode (p29003 = 2).</li> </ul> </li> <li>The bit 4 of p29025 will not be set to 1 automatically if either of the following conditions is fulfilled:               <ul style="list-style-type: none"> <li>Working with the 400 V drives</li> <li>Working in all control modes except for the S control mode (p29003 ≠ 2).</li> </ul> </li> <li>You can set the bit 4 of p29025 manually in all control modes.</li> </ul>							
p29026	Tuning: Test signal duration	0	5000	2000	ms	U32	IM	T
	<b>Description:</b> The duration time of the one-button auto tuning test signal.							
p29027	Tuning: Limit rotation of motor	0	30000	0	°	U32	IM	T
	<b>Description:</b> The limit position with motor rotations during one-button auto tuning. The traversing range is limited within +/- p29027 degrees (motor run one revolution is 360 degree).							
p29028	Tuning: Pre-control time constant	0.0	60.0	7.5	ms	Float	IM	T, U
	<b>Description:</b> Sets the time constant for the pre-control symmetrization for auto tuning. As a consequence, the drive is allocated a defined, dynamic response via its pre-control. For drives, which must interpolate with one another, the same value must be entered. The higher this time constant is, the smoother the drive will follow the position set point. <b>Note:</b> This time constant is only effective when multi-axis interpolation is selected (bit 7 of p29023 and p29024).							
p29030	PTO: Number of pulse per revolution	0, 30	16384	1000	-	U32	IM	T
	<b>Description:</b> Number of output pulses per motor revolution. If this value is 0, the number of required output pulses is decided by the electronic gear ratio.							
p29031	PTO: Numerator of electronic gear	1	214700000 0	1	-	U32	IM	T
	<b>Description:</b> The numerator of the electronic gear ratio for the output pulses. For detailed information about the calculation of a numerator, refer to the SINAMICS V90 Operating Instructions or use the SINAMICS V-ASSISTANT to do the calculation.							
p29032	PTO: Denominator electronic gear	1	214700000 0	1	-	U32	IM	T
	<b>Description:</b> The denominator of the electronic gear ratio for the output pulses. For detailed information about the calculation of a denominator, refer to the SINAMICS V90 Operating Instructions or use the SINAMICS V-ASSISTANT to do the calculation.							

Par. No.	Name	Min	Max	Factory Setting	Unit	Data type	Effective	Can be changed
p29033	PTO: Direction change	0	1	0	-	I16	IM	T
	<p><b>Description:</b> Select the PTO direction.</p> <ul style="list-style-type: none"> <li>0: PTO positive PTO direction does not change. PTO A leads PTO B with 90 degrees when the motor rotates in clockwise direction. PTO B leads PTO A with 90 degrees when the motor rotates in counter-clockwise direction.</li> <li>1: PTO negative PTO direction changes. PTO A leads PTO B with 90 degrees when the motor rotates in counter-clockwise direction. PTO B leads PTO A with 90 degrees when the motor rotates in clockwise direction.</li> </ul>							
p29035	VIBSUP activation	0	1	0	-	I16	IM	T
	<p><b>Description:</b> Select the VIBSUP on/off. Position setpoint filter can be activated (p29035) for IPos control mode.</p> <ul style="list-style-type: none"> <li>0: Disable Filter is not activated.</li> <li>1: Enable Filter is activated.</li> </ul>							
p29041[0..1]	Torque scaling	0	[0] 100 [1] 300	[0] 100 [1] 300	%	Float	IM	T
	<p><b>Description:</b></p> <ul style="list-style-type: none"> <li>[0]: The scaling for the analog torque setpoint. With this parameter, you can specify the torque setpoint corresponding to full analog input (10 V).</li> <li>[1]: The scaling for the analog torque limit. With this parameter, you can specify the torque limit corresponding to full analog input (10 V).</li> </ul> <p>You can select the internal parameters or the analog input as the source of the torque limit with the combination of the digital input signals TLIM1 and TLIM2.</p>							
	<p><b>Index:</b> [0]: Torque set scale [1]: Torque limit scale</p>							
p29042	Offset adjustment for analog input 2	-0.5000	0.5000	0.0000	V	Float	IM	T
	<p><b>Description:</b> Offset adjustment for the analog input 2.</p>							
p29043	Fixed torque setpoint	-100	100	0	%	Float	IM	U, T
	<p><b>Description:</b> Fixed torque setpoint. You can select the internal parameters or the analog input as the source of the torque setpoint by configuring the digital input signal TSET.</p>							
p29045	PTI: activate travel to fixed stop	0	1	0	-	I16	IM	T
	<p><b>Description:</b> Activate/deactivate "travel to fixed stop" function under PTI control mode.</p> <ul style="list-style-type: none"> <li>1: Travel to fixed stop is active</li> <li>0: Travel to fixed stop is inactive</li> </ul>							

Par. No.	Name	Min	Max	Factory Setting	Unit	Data type	Effective	Can be changed
p29050[0..2]	Torque limit upper	-150	300	300	%	Float	IM	T
	<b>Description:</b> Positive torque limit. Three internal torque limits in total are available. You can select the internal parameters or the analog input as the source of the torque limit with the combination of the digital input signals TLIM1 and TLIM2.							
p29051[0..2]	Torque limit lower	-300	150	-300	%	Float	IM	T
	<b>Description:</b> Negative torque limit. Three internal torque limits in total are available. You can select the internal parameters or the analog input as the source of the torque limit with the combination of the digital input signals TLIM1 and TLIM2.							
p29060 *	Speed scaling	6	210000	3000	rpm	Float	IM	T
	<b>Description:</b> The scaling for the analog speed setpoint. With this parameter, you can specify the speed setpoint corresponding to full analog input (10 V).							
p29061	Offset adjustment for analog input 1	-0.5000	0.5000	0.0000	V	Float	IM	T
	<b>Description:</b> Offset adjustment for the analog input 1.							
p29070[0..2] *	Speed limit positive	0	210000	210000	rpm	Float	IM	T
	<b>Description:</b> Positive speed limit. Three internal speed limits in total are available. You can select the internal parameters or the analog input as the source of the speed limit with the combination of the digital input signals SLIM1 and SLIM2.							
p29071[0..2] *	Speed limit negative	-210000	0	-210000	rpm	Float	IM	T
	<b>Description:</b> Negative speed limit. Three internal speed limits in total are available. You can select the internal parameters or the analog input as the source of the speed limit with the combination of the digital input signals SLIM1 and SLIM2.							
p29075	Speed clamp threshold	0	200	200	rpm	Float	IM	T
	<b>Description:</b> The threshold for the zero speed clamp. If the function of zero speed clamp has been enabled under the speed control mode, the motor speed is clamped to 0 when both the setpoint speed and the actual speed are below this threshold.							
p29078	Speed reach threshold	0.0	100.0	10	rpm	Float	IM	T
	<b>Description:</b> Speed reached range (deviation between setpoint and motor speed)							
p29080	Overload threshold for output signal triggering	10	300	100	%	Float	IM	T
	<b>Description:</b> Overload threshold for the output power.							
p29090	Offset Adjustment for Analog output 1	-0.50	0.50	0.00	V	Float	IM	T
	<b>Description:</b> Offset adjustment for analog output 1.							
p29091	Offset adjustment for analog output 2	-0.50	0.50	0.00	V	Float	IM	T
	<b>Description:</b> Offset adjustment for analog output 2.							

## 10.2 Parameter list

Par. No.	Name	Min	Max	Factory Setting	Unit	Data type	Effective	Can be changed
p29110[0..1] **	Position loop gain	0.000	300.000	[0] Motor dependent [1] 1.000	1000/min	Float	IM	T, U
	<b>Description:</b> Position loop gain. Two position loop gains in total are available. You can switch between these two gains by configuring the digital input signal G-CHANGE or setting relevant condition parameters. The first position loop gain is the default setting.							
	<b>Dependency:</b> The parameter value will be set to default after configuring a new motor ID (p29000).							
p29111	Speed pre-control factor (feed forward)	0.00	200.00	0.00	%	Float	IM	T, U
	<b>Description:</b> Setting to activate and weight the speed pre-control value. Value = 0%: The pre-control is deactivated.							
p29120[0..1] **	Speed loop gain	0.00	999999.00	[0] Motor dependent [1] 0.30	Nms/rad	Float	IM	T, U
	<b>Description:</b> Speed loop gain. Two speed loop gains in total are available. You can switch between these two gains by configuring the digital input signal G-CHANGE or setting relevant condition parameters. The first speed loop gain is the default setting.							
	<b>Dependency:</b> The parameter value will be set to default after configuring a new motor ID (p29000).							
p29121[0..1] *	Speed loop integral time	0.00	100000.00	[0] 15 [1] 20	ms	Float	IM	T, U
	<b>Description:</b> Speed loop integral time. Two speed loop integral time values in total are available. You can switch between these two time values by configuring the digital input signal G-CHANGE or setting relevant condition parameters. The first speed loop integral time is the default setting.							
	<b>Dependency:</b> The parameter value will be set to default after configuring a new motor ID (p29000).							
p29130	Gain switching: Mode selection	0	4	0	-	I16	IM	T
	<b>Description:</b> Selects gain switching mode. <ul style="list-style-type: none"> <li>• 0: Disabled</li> <li>• 1: Switch through DI-G-CHANG</li> <li>• 2: Position deviation as switch condition</li> <li>• 3: Pulse input frequency as switch condition</li> <li>• 4: Actual speed as switch condition</li> </ul> <b>Note:</b> Only when the auto tuning function (p20021=0) is disabled can the gain switching function be used.							

Par. No.	Name	Min	Max	Factory Setting	Unit	Data type	Effective	Can be changed
p29131	Gain switching condition: Pulse deviation	0	2147483647	100	LU	I32	IM	T
	<p><b>Description:</b> Triggers position deviation threshold for gain switching. If the gain switching function is enabled and this condition is selected:</p> <ul style="list-style-type: none"> <li>• Switch from the first group of control parameters to the second group when the position deviation is larger than the threshold.</li> <li>• Switch from the second group of control parameters to the first group when the position deviation is smaller than the threshold.</li> </ul>							
p29132	Gain switching condition: Position setpoint frequency	0	2147000064	100	100 0 LU/ min	Float	IM	T
	<p><b>Description:</b> Triggers pulse input frequency (PTI) threshold or internal position speed (IPos) threshold for gain switching. If the gain switching function is enabled and this condition is selected:</p> <ol style="list-style-type: none"> <li>1. PTI <ul style="list-style-type: none"> <li>– Switch from the first group of control parameters to the second group when the pulse train input pulse is higher than the threshold.</li> <li>– Switch from the second group of control parameters to the first group when the pulse train input is lower than the threshold.</li> </ul> </li> <li>2. IPos <ul style="list-style-type: none"> <li>– Switch from the first group of control parameters to the second group when the speed of fixed position setpoint is larger than the threshold.</li> <li>– Switch from the second group of control parameters to the first group when the IPos is smaller than the threshold.</li> </ul> </li> </ol>							
p29133	Gain switching condition: Actual speed	0	2147000064	100	rpm	Float	IM	T
	<p><b>Description:</b> Triggers speed threshold for gain switching. If the gain switching function is enabled and this condition is selected:</p> <ul style="list-style-type: none"> <li>• Switch from the first group of control parameters to the second group when the actual motor speed is larger than the threshold.</li> <li>• Switch from the second group of control parameters to the first group when the actual motor speed is smaller than the threshold.</li> </ul>							
p29139	Gain switching time constant	8	1000	20	ms	Float	IM	T
	<p><b>Description:</b> Time constant for gain switching. Set this parameter to avoid frequent gain switches that reduces system reliability.</p>							
p29140	PI to P: Mode selection	0	5	0	-	U16	IM	T
	<p><b>Description:</b> Selects a condition for the switch from PI control to P control under the speed loop.</p> <ul style="list-style-type: none"> <li>• 0: Disabled</li> <li>• 1: Torque is higher than a parameterizable setting value.</li> <li>• 2: Using the digital input signal (G-CHANGE).</li> <li>• 3: Speed is higher than a parameterizable setting value.</li> <li>• 4: Acceleration is higher than a parameterizable setting value.</li> <li>• 5: Pulse deviation is higher than a parameterizable setting value.</li> </ul> <p><b>Note:</b> Only when the auto tuning function (p29021=0) and gain switching function are both disabled can the PI/P switching function be used.</p>							

Par. No.	Name	Min	Max	Factory Setting	Unit	Data type	Effective	Can be changed
p29141	PI to P switching condition: Torque	0	300	200	%	Float	IM	T
	<p><b>Description:</b> Triggers torque threshold for PI/P switching. If the PI/P switching function is enabled and this condition is selected:</p> <ul style="list-style-type: none"> <li>• Switch from the PI control to the P control when the actual torque is larger than the threshold.</li> <li>• Switch from the P control to the PI control when the actual torque is smaller than the threshold.</li> </ul>							
p29142	PI to P switching condition: Speed	0	210000	2000	rpm	Float	IM	T
	<p><b>Description:</b> Triggers speed threshold for PI/P switching. If the PI/P switching function is enabled and this condition is selected:</p> <ul style="list-style-type: none"> <li>• Switch from the PI control to the P control when the actual speed is larger than the threshold.</li> <li>• Switch from the P control to the PI control when the actual speed is smaller than the threshold.</li> </ul>							
p29143	PI to P switching condition: Acceleration	0	30000	20	rev/s <sup>2</sup>	Float	IM	T
	<p><b>Description:</b> Triggers acceleration threshold for PI/P switching. If the PI/P switching function is enabled and this condition is selected:</p> <ul style="list-style-type: none"> <li>• Switch from the PI control to the P control when the actual acceleration is larger than the threshold.</li> <li>• Switch from the P control to the PI control when the actual acceleration is smaller than the threshold.</li> </ul>							
p29144	PI to P switching condition: Pulse deviation	0	2147483647	30000	LU	U32	IM	T
	<p><b>Description:</b> Triggers pulse deviation threshold for PI/P switching. If the PI/P switching function is enabled and this condition is selected:</p> <ul style="list-style-type: none"> <li>• Switch from the PI control to the P control when the actual pulse deviation is larger than the threshold.</li> <li>• Switch from the P control to the PI control when the actual pulse deviation is smaller than the threshold.</li> </ul>							
p29230	MDI direction selection	0	2	0	-	I16	IM	T
	<p><b>Description:</b> MDI direction selection:</p> <ul style="list-style-type: none"> <li>• 0: Absolute positioning through the shortest distance</li> <li>• 1: Absolute positioning through the positive direction</li> <li>• 2: Absolute positioning through the negative direction</li> </ul>							
p29240	Select referencing mode	0	4	1	-	I16	IM	T
	<p><b>Description:</b> Selects referencing mode.</p> <ul style="list-style-type: none"> <li>• 0: Referencing with external signal REF</li> <li>• 1: Referencing with external reference cam (signal REF) and encoder zero mark</li> <li>• 2: Referencing with zero mark only</li> <li>• 3: Referencing with external reference cam (CCWL) and zero mark</li> <li>• 4: Referencing with external reference cam (CWL) and zero mark</li> </ul>							
p29241	Positioning mode selection	0	3	0	-	U16	IM	T
	<p><b>Description:</b> Moves mode set for IPos:</p> <ul style="list-style-type: none"> <li>• 0: Means relative moving</li> <li>• 1: Means abs moving</li> <li>• 2: POS Mod</li> <li>• 3: NEG Mod</li> </ul>							

Par. No.	Name	Min	Max	Factory Setting	Unit	Data type	Effective	Can be changed
p29242	CLR pulse mode	0	2	0	-	U16	IM	T
	<b>Description:</b> Select clear pulse mode <ul style="list-style-type: none"> <li>• 0: Disabled</li> <li>• 1: Means clear pulse on high level</li> <li>• 2: Means clear pulse on rising edge</li> </ul>							
p29243	Positioning tracking activate	0	1	0	-	I16	IM	T
	<b>Description:</b> Activation of position tracking. <ul style="list-style-type: none"> <li>• 0: Deactivated</li> <li>• 1: Activated</li> </ul>							
p29244	Absolute encoder virtual rotary revolutions	0	4096	0	-	U32	IM	T
	<b>Description:</b> Sets the number of rotations that can be resolved for an encoder with activated position tracking function (p29243 = 1).							
p29245	Axis mode state	0	1	0	-	U32	IM	T
	<b>Description:</b> Linear/modulo mode: <ul style="list-style-type: none"> <li>• 0: Linear axis</li> <li>• 1: Modulo axis</li> </ul>							
p29246 *	Modulo correction range	1	214748264 7	360000	LU	U32	IM	T
	<b>Description:</b> Sets the modulo range for axes with modulo correction.							
p29247 *	Mechanical gear: LU per revolution	1	214748364 7	10000	-	U32	IM	T
	<b>Description:</b> LU per load revolution.							
p29248 *	Mechanical gear: Numerator	1	1048576	1	-	U32	IM	T
	<b>Description:</b> (Load/Motor) Load revolutions.							
p29249 *	Mechanical gear: denominator	1	1048576	1	-	U32	IM	T
	<b>Description:</b> (Load/Motor) Motor revolutions.							
p29250	PTI absolute position mode enable	0	1	0	-	U32	RE	T
	<b>Description:</b> Absolute position mode enable. <ul style="list-style-type: none"> <li>• 1: Enable Absolute Mode</li> <li>• 0: Disable Absolute Mode</li> </ul>							

## 10.2 Parameter list

Par. No.	Name	Min	Max	Factory Setting	Unit	Data type	Effective	Can be changed
p29300	Digital input forced signals	0	127	0	-	U32	IM	T, U
<p><b>Description:</b> assignment signals are forced to be high. 7 bits in total.</p> <ul style="list-style-type: none"> <li>• Bit 0: SON</li> <li>• Bit 1: CWL</li> <li>• Bit 2: CCWL</li> <li>• Bit 3: TLIM1</li> <li>• Bit 4: SPD1</li> <li>• Bit 5: TSET</li> <li>• Bit 6: EMGS</li> </ul> <p>If one or more bits are set to be high, the corresponding input signals are forced to be logical high signals.</p> <p><b>Note:</b> The drive unit displays the value in hex format. To know the logic (high/low) assignment to each bit, you must convert the hex number to the binary number, for example, FF (hex) = 11111111 (bin).</p>								
p29301[0..3]	Digital input 1 assignment	0	28	1	-	I16	IM	T
<p><b>Description:</b> Defines the function of digital input signal DI1 (PT1 mode)</p> <ul style="list-style-type: none"> <li>• 1: SON</li> <li>• 2: RESET</li> <li>• 3: CWL</li> <li>• 4: CCWL</li> <li>• 5: G-CHANGE</li> <li>• 6: P-TRG</li> <li>• 7: CLR</li> <li>• 8: EGEAR1</li> <li>• 9: EGEAR2</li> <li>• 10: TLIM1</li> <li>• 11: TLIM2</li> <li>• 12: CWE</li> <li>• 13: CCWE</li> <li>• 14: ZSCLAMP</li> <li>• 15: SPD1</li> <li>• 16: SPD2</li> <li>• 17: SPD3</li> <li>• 18: TSET</li> <li>• 19: SLIM1</li> <li>• 20: SLIM2</li> <li>• 21: POS1</li> <li>• 22: POS2</li> <li>• 23: POS3</li> <li>• 24: REF</li> <li>• 25: SREF</li> <li>• 26: STEPF</li> <li>• 27: STEPB</li> <li>• 28: STEPH</li> </ul>								



Par. No.	Name	Min	Max	Factory Setting	Unit	Data type	Effective	Can be changed
	<b>Index:</b> <ul style="list-style-type: none"> <li>• [0]: DI1 for control mode 0</li> <li>• [1]: DI1 for control mode 1</li> <li>• [2]: DI1 for control mode 2</li> <li>• [3]: DI1 for control mode 3</li> </ul>							
p29302[0..3]	Digital input 2 assignment	0	28	2	-	l16	IM	T
	<b>Description:</b> Defines the function of digital input signal DI2							
	<b>Index:</b> <ul style="list-style-type: none"> <li>• [0]: DI2 for control mode 0</li> <li>• [1]: DI2 for control mode 1</li> <li>• [2]: DI2 for control mode 2</li> <li>• [3]: DI2 for control mode 3</li> </ul>							
p29303[0..3]	Digital input 3 assignment	0	28	3	-	l16	IM	T
	<b>Description:</b> Defines the function of digital input signal DI3							
	<b>Index:</b> <ul style="list-style-type: none"> <li>• [0]: DI3 for control mode 0</li> <li>• [1]: DI3 for control mode 1</li> <li>• [2]: DI3 for control mode 2</li> <li>• [3]: DI3 for control mode 3</li> </ul>							
p29304[0..3]	Digital input 4 assignment	0	28	4	-	l16	IM	T
	<b>Description:</b> Defines the function of digital input signal DI4							
	<b>Index:</b> <ul style="list-style-type: none"> <li>• [0]: DI4 for control mode 0</li> <li>• [1]: DI4 for control mode 1</li> <li>• [2]: DI4 for control mode 2</li> <li>• [3]: DI4 for control mode 3</li> </ul>							
p29305[0..3]	Digital input 5 assignment	0	28	[0] 5; [1] 5; [2] 12; [3] 12	-	l16	IM	T
	<b>Description:</b> Defines the function of digital input signal DI5							
	<b>Index:</b> <ul style="list-style-type: none"> <li>• [0]: DI5 for control mode 0</li> <li>• [1]: DI5 for control mode 1</li> <li>• [2]: DI5 for control mode 2</li> <li>• [3]: DI5 for control mode 3</li> </ul>							
p29306[0..3]	Digital input 6 assignment	0	28	[0] 6; [1] 6; [2] 13; [3] 13	-	l16	IM	T
	<b>Description:</b> Defines the function of digital input signal DI6							

## 10.2 Parameter list

Par. No.	Name	Min	Max	Factory Setting	Unit	Data type	Effective	Can be changed
	<b>Index:</b> <ul style="list-style-type: none"> <li>[0]: DI6 for control mode 0</li> <li>[1]: DI6 for control mode 1</li> <li>[2]: DI6 for control mode 2</li> <li>[3]: DI6 for control mode 3</li> </ul>							
p29307[0..3]	Digital input 7 assignment	0	28	[0] 7; [1] 21; [2] 15; [3] 18	-	I16	IM	T
	<b>Description:</b> Defines the function of digital input signal DI7							
	<b>Index:</b> <ul style="list-style-type: none"> <li>[0]: DI7 for control mode 0</li> <li>[1]: DI7 for control mode 1</li> <li>[2]: DI7 for control mode 2</li> <li>[3]: DI7 for control mode 3</li> </ul>							
p29308[0..3]	Digital input 8 assignment	0	28	[0] 10; [1] 22; [2] 16; [3] 19	-	I16	IM	T
	<b>Description:</b> Defines the function of digital input signal DI8							
	<b>Index:</b> <ul style="list-style-type: none"> <li>[0]: DI8 for control mode 0</li> <li>[1]: DI8 for control mode 1</li> <li>[2]: DI8 for control mode 2</li> <li>[3]: DI8 for control mode 3</li> </ul>							
p29330	Digital output 1 assignment	1	15	1	-	I16	IM	T
	<b>Description:</b> Defines the function of digital output signal DO1 <ul style="list-style-type: none"> <li>1: RDY</li> <li>2: FAULT</li> <li>3: INP</li> <li>4: ZSP</li> <li>5: SPDR</li> <li>6: TLR</li> <li>7: SPLR</li> <li>8: MBR</li> <li>9: OLL</li> <li>10: WARNING1</li> <li>11: WARNING2</li> <li>12: REFOK</li> <li>13: CM_STA</li> <li>14: RDY_ON</li> <li>15: STO_EP</li> </ul>							

Par. No.	Name	Min	Max	Factory Setting	Unit	Data type	Effective	Can be changed
p29331	Digital output 2 assignment	1	15	2	-	I16	IM	T
<b>Description:</b> Defines the function of digital output signal DO2								
p29332	Digital output 3 assignment	1	15	3	-	I16	IM	T
<b>Description:</b> Defines the function of digital output signal DO3								
p29333	Digital output 4 assignment	1	15	5	-	I16	IM	T
<b>Description:</b> Defines the function of digital output signal DO4								
p29334	Digital output 5 assignment	1	15	6	-	I16	IM	T
<b>Description:</b> Defines the function of digital output signal DO5								
p29335	Digital output 6 assignment	1	15	8	-	I16	IM	T
<b>Description:</b> Defines the function of digital output signal DO6								
p29340	Warning 1 assigned for digital output	1	6	1	-	U16	IM	T
<b>Description:</b> Defines conditions for WRN1.								
<ul style="list-style-type: none"> <li>• 1: Motor overload protection warning: 85% of overload threshold has been reached.</li> <li>• 2: Holding brake power overload warning: threshold p29005 has been reached.</li> <li>• 3: Fan warning: fan has stopped for more than 1 s.</li> <li>• 4: Encoder warning</li> <li>• 5: Motor overtemperature warning: 85% of overtemperature threshold has been reached.</li> <li>• 6: Capacitor service life warning: The capacitor has reached its expiry, so replace it.</li> </ul>								
p29341	Warning 2 assigned for digital output	1	6	2	-	U16	IM	T
<b>Description:</b> Defines conditions for WARNING2.								
<ul style="list-style-type: none"> <li>• 1: Motor overload protection warning: 85% of overload threshold has been reached.</li> <li>• 2: Holding brake power overload warning: threshold p29005 has been reached.</li> <li>• 3: Fan warning: life time of fan expired (40000 hours), replacement of fan needed.</li> <li>• 4: Encoder warning</li> <li>• 5: Motor overtemperature warning: 85% of overtemperature threshold has been reached.</li> <li>• 6: Capacitor service life warning: The capacitor has reached its expiry, so replace it.</li> </ul>								

Par. No.	Name	Min	Max	Factory Setting	Unit	Data type	Effective	Can be changed
p29350	Select sources for analog output 1	0	12	0	-	U16	IM	T
	<p><b>Description:</b> Selects signal source for analog output 1.</p> <ul style="list-style-type: none"> <li>0: Actual speed (reference p29060)</li> <li>1: Actual torque (reference 3 × r0333)</li> <li>2: Speed setpoint (reference p29060)</li> <li>3: Torque setpoint (reference 3 × r0333)</li> <li>4: DC bus voltage (reference 1000 V)</li> <li>5: Pulse input frequency (reference 1k)</li> <li>6: Pulse input frequency (reference 10k)</li> <li>7: Pulse input frequency (reference 100k)</li> <li>8: Pulse input frequency (reference 1000k)</li> <li>9: Remaining number of pulses (reference 1k)</li> <li>10: Remaining number of pulses (reference 10k)</li> <li>11: Remaining number of pulses (reference 100k)</li> <li>12: Remaining number of pulses (reference 1000k)</li> </ul>							
p29351	Select signal source for analog 2	0	12	1	-	U16	IM	T
	<p><b>Description:</b> Selects signals for analog output 2.</p> <ul style="list-style-type: none"> <li>0: Actual speed (reference p29060)</li> <li>1: Actual torque (reference 3 × r0333)</li> <li>2: Speed setpoint (reference p29060)</li> <li>3: Torque setpoint (reference 3 × r0333)</li> <li>4: DC bus voltage (reference 1000 V)</li> <li>5: Pulse input frequency (reference 1k)</li> <li>6: Pulse input frequency (reference 10k)</li> <li>7: Pulse input frequency (reference 100k)</li> <li>8: Pulse input frequency (reference 1000k)</li> <li>9: Remaining number of pulses (reference 1k)</li> <li>10: Remaining number of pulses (reference 10k)</li> <li>11: Remaining number of pulses (reference 100k)</li> <li>12: Remaining number of pulses (reference 1000k)</li> </ul>							
p29360	Brake resistor alarm active	0	1	1	-	I16		
	<p><b>Description:</b> Configure the deactivation of the brake resistor alarm.</p> <ul style="list-style-type: none"> <li>0: A52901 monitor is activated.</li> <li>1: A52901 monitor is deactivated.</li> </ul>							

Par. No.	Name	Min	Max	Factory Setting	Unit	Data type	Effective	Can be changed
p31581	VIBSUP: Filter type	0	1	0	-	116	IM	T
	<p><b>Description:</b> Sets the filter type for VIBSUP. Depending on the selected filter type, the VIBSUP filter results in motion sequences that take somewhat longer.</p> <ul style="list-style-type: none"> <li>0: The rugged VIBSUP filter has a lower sensitivity to frequency offsets compared with the sensitive filter type, but results in a higher delay of the motion sequence. The total motion sequence is extended by the time period <math>T_d</math> (<math>T_d = 1/f_d</math>).</li> <li>1: The sensitive VIBSUP filter has a higher sensitivity to frequency offsets compared with the rugged filter type, but results in a lower delay of the motion sequence. The total motion sequence is extended by half the time period <math>T_d/2</math> (<math>T_d = 1/f_d</math>).</li> </ul>							
p31585	VIBSUP: Filter frequency $f_d$	0.5	62.5	1	Hz	Float 32	IM	T
	<p><b>Description:</b> Sets the frequency of the damped natural vibration of the mechanical system. This frequency can be determined by making the appropriate measurements.</p> <p><b>Note:</b> The maximum frequency that can be set depends on the filter sampling time.</p>							
p31586	VIBSUP: Filter damping	0.00	0.99	0.03	-	Float 32	IM	T
	<p><b>Description:</b> Sets the value for the damping of the natural mechanical vibration to be filtered. Typically, the damping value is about 0.03, and can be optimized by performing the appropriate positioning tests.</p>							

### Read-only parameters

Par. No.	Name	Unit	Data type
r0020	Speed setpoint smoothed	rpm	Float
	<p><b>Description:</b> Displays the currently smoothed speed setpoint at the input of the speed controller or U/f characteristic (after the interpolator).</p> <p><b>Note:</b> Smoothing time constant = 100 ms The signal is not suitable as a process quantity and may only be used as a display quantity. The speed setpoint is available smoothed (r0020) and unsmoothed.</p>		
r0021	Actual speed smoothed	rpm	Float
	<p><b>Description:</b> Displays the smoothed actual value of the motor speed.</p> <p><b>Note:</b> Smoothing time constant = 100 ms The signal is not suitable as a process quantity and may only be used as a display quantity. The speed actual value is available smoothed (r0021) and unsmoothed.</p>		
r0026	DC link voltage smoothed	V	Float
	<p><b>Description:</b> Displays the smoothed actual value of the DC link voltage.</p> <p><b>Note:</b> Smoothing time constant = 100 ms The signal is not suitable as a process quantity and may only be used as a display quantity. The DC link voltage is available smoothed.</p>		
r0027	Absolute actual current smoothed	Arms	Float
	<p><b>Description:</b> Displays the smoothed absolute actual current value.</p> <p><b>Notice:</b> This smoothed signal is not suitable for diagnostics or evaluation of dynamic operations. In this case, the unsmoothed value should be used.</p> <p><b>Note:</b> Smoothing time constant = 100 ms The signal is not suitable as a process quantity and may only be used as a display quantity. The absolute current actual value is available smoothed (r0027) and unsmoothed.</p>		

Par. No.	Name	Unit	Data type
r0029	Current actual value field-generating smoothed	Arms	Float
	<b>Description:</b> Displays the smoothed field-generating actual current.		
	<b>Note:</b> Smoothing time constant = 100 ms The signal is not suitable as a process quantity and may only be used as a display quantity. The field-generating current actual value is available smoothed (r0029) and unsmoothed.		
r0030	Current actual value torque-generating smoothed	Arms	Float
	<b>Description:</b> Displays the smoothed torque-generating actual current.		
	<b>Note:</b> Smoothing time constant = 100 ms The signal is not suitable as a process quantity and may only be used as a display quantity. The torque-generating current actual value is available smoothed.		
r0031	Actual torque smoothed	Nm	Float
	<b>Description:</b> Displays the smoothed torque actual value.		
	<b>Note:</b> Smoothing time constant = 100 ms The signal is not suitable as a process quantity and may only be used as a display quantity. The torque actual value is available smoothed (r0031) and unsmoothed.		
r0032	Active power actual value smoothed	kW	Float
	<b>Description:</b> Displays the smoothed actual value of the active power.		
r0033	Torque utilization smoothed	%	Float
	<b>Description:</b> Displays the smoothed torque utilization as a percentage. The torque utilization is obtained from the required smoothed torque in reference to the torque limit, scaled using p2196.		
	<b>Note:</b> Smoothing time constant = 100 ms The signal is not suitable as a process quantity and may only be used as a display quantity. The torque utilization is available smoothed (r0033) and unsmoothed. For M_set total (r0079) > M_max offset, the following applies: <ul style="list-style-type: none"> <li>• demanded torque = M_set total - M_max offset</li> <li>• actual torque limit = M_max upper effective - M_max offset</li> </ul> For M_set total (r0079) ≤ M_max offset (p1532), the following applies: <ul style="list-style-type: none"> <li>• demanded torque = M_max offset - M_set total</li> <li>• actual torque limit = M_max offset - M_max lower effective</li> </ul> For the actual torque limit = 0, the following applies: r0033 = 100 % For the actual torque limit < 0, the following applies: r0033 = 0 %		
r0034	Motor utilization thermal	%	Float
	<b>Description:</b> Displays the motor utilization from motor temperature model 1 (I <sup>2</sup> t) or 3.		
r0037[0...19]	Power unit temperatures	°C	Float
	<b>Description:</b> Displays the temperatures in the power unit.		
	<b>Index:</b> <ul style="list-style-type: none"> <li>• [0]: Inverter maximum value</li> <li>• [1]: Depletion layer maximum value</li> <li>• [2]: Rectifier maximum value</li> <li>• [3]: Air intake</li> <li>• [4]: Interior of power unit</li> </ul>		

Par. No.	Name	Unit	Data type
	<ul style="list-style-type: none"> <li>• [5]: Inverter 1</li> <li>• [6]: Inverter 2</li> <li>• [7]: Inverter 3</li> <li>• [8]: Inverter 4</li> <li>• [9]: Inverter 5</li> <li>• [10]: Inverter 6</li> <li>• [11]: Rectifier 1</li> <li>• [12]: Rectifier 2</li> <li>• [13]: Depletion layer 1</li> <li>• [14]: Depletion layer 2</li> <li>• [15]: Depletion layer 3</li> <li>• [16]: Depletion layer 4</li> <li>• [17]: Depletion layer 5</li> <li>• [18]: Depletion layer 6</li> <li>• [19]: Cooling unit liquid intake</li> </ul>		
	<b>Dependency:</b> Refer to A01009		
	<b>Notice:</b> Only for internal Siemens troubleshooting.		
	<b>Note:</b> The value of -200 indicates that there is no measuring signal. <ul style="list-style-type: none"> <li>• r0037[0]: Maximum value of the inverter temperatures (r0037[5...10]).</li> <li>• r0037[1]: Maximum value of the depletion layer temperatures (r0037[13...18]).</li> <li>• r0037[2]: Maximum value of the rectifier temperatures (r0037[11...12]).</li> </ul> The maximum value is the temperature of the hottest inverter, depletion layer, or rectifier.		
r0079[0...1]	Torque setpoint total	Nm	Float
	<b>Description:</b> Displays and connector output for the torque setpoint at the output of the speed controller (before clock cycle interpolation).		
	<b>Index:</b>		
	<ul style="list-style-type: none"> <li>• [0]: Unsmoothed</li> <li>• [1]: Smoothed</li> </ul>		
r0296	DC link voltage undervoltage threshold	V	U16
	<b>Description:</b> Threshold to detect a DC link undervoltage. If the DC link voltage falls below this threshold, the drive unit is tripped due to a DC link undervoltage condition.		
	<b>Note:</b> The value depends on the device type and the selected device rated voltage.		
r0297	DC link voltage overvoltage threshold	V	U16
	<b>Description:</b> If the DC link voltage exceeds the threshold specified here, the drive unit is tripped due to DC link overvoltage.		
	<b>Dependency:</b> Refer to F30002.		
r0311	Rated motor speed	rpm	Float
	<b>Description:</b> Displays the rated motor speed (rating plate).		
r0333	Rated motor torque	Nm	Float
	<b>Description:</b> Displays the rated motor torque. IEC drive: unit Nm NEMA drive: unit lbf ft		

Par. No.	Name	Unit	Data type
r0482[0...2 ]	Encoder actual position value Gn_XIST1	-	U32
	<b>Description:</b> Displays the encoder actual position value <b>Gn_XIST1</b> .		
	<b>Index:</b> <ul style="list-style-type: none"> <li>• [0]: Encoder 1</li> <li>• [1]: Encoder 2</li> <li>• [2]: Reserved</li> </ul>		
	<b>Note:</b> <ul style="list-style-type: none"> <li>• In this value, the measuring gear is only taken into account when the position tracking is activated.</li> <li>• The update time for the position control (EPOS) corresponds to the position controller clock cycle.</li> <li>• The update time in isochronous operation corresponds to the bus cycle time.</li> <li>• The update time in isochronous operation and with position control (EPOS) corresponds to the position controller clock cycle.</li> <li>• The update time in non-isochronous operation or without position control (EPOS) comprises the following: <ul style="list-style-type: none"> <li>– Update time = 4 * least common multiple (LCM) of all current controller clock cycles in the drive group (infeed + drives). The minimum update time is 1 ms.</li> <li>– Example 1: infeed, servo Update time = 4 * LCM(250 µs, 125 µs) = 4 * 250 µs = 1 ms</li> <li>– Example 2: infeed, servo, vector Update time = 4 * LCM(250 µs, 125 µs, 500 µs) = 4 * 500 µs = 2 ms</li> </ul> </li> </ul>		
r0632	Motor temperature model, stator winding temperature	°C	Float
	<b>Description:</b> Displays the stator winding temperature of the motor temperature model.		
r0722	CU digital inputs status	-	U32
	<b>Description:</b> Displays the status of the digital inputs.		
	<b>Note:</b> DI: Digital input DI/DO: Bidirectional digital input/output The drive unit displays the value in hex format. You can convert the hex number to the binary number, for example, FF (hex) = 11111111 (bin).		
r0747	CU digital outputs status	-	U32
	<b>Description:</b> Displays the status of digital outputs.		
	<b>Note:</b> DI/DO: Bidirectional digital input/output The drive unit displays the value in hex format. You can convert the hex number to the binary number, for example, FF (hex) = 11111111 (bin).		
r0807.0	Master control active	-	U8
	<b>Description:</b> Displays what has the master control. The drive can be controlled via the internal interconnection or from external.		
r0945[0...6 3]	Fault code	-	U16
	<b>Description:</b> Displays the number of faults that have occurred.		
	<b>Dependency:</b> Refer to r0949		



Par. No.	Name	Unit	Data type
	<p><b>Note:</b> The buffer parameters are cyclically updated in the background.</p> <p>Fault buffer structure (general principle):</p> <p>r0945[0], r0949[0] → actual fault case, fault 1</p> <p>...</p> <p>r0945[7], r0949[7] → actual fault case, fault 8</p> <p>r0945[8], r0949[8] → 1st acknowledged fault case, fault 1</p> <p>...</p> <p>r0945[15], r0949[15] → 1st acknowledged fault case, fault 8</p> <p>...</p> <p>r0945[56], r0949[56] → 7th acknowledged fault case, fault 1</p> <p>...</p> <p>r0945[63], r0949[63] → 7th acknowledged fault case, fault 8</p>		
r0949[0...63]	Fault value	-	I32
	<p><b>Description:</b> Displays additional information about the fault that occurred (as integer number).</p>		
	<p><b>Dependency:</b> Refer to r0945</p>		
	<p><b>Note:</b> The buffer parameters are cyclically updated in the background.</p> <p>The structure of the fault buffer and the assignment of the indices is shown in r0945.</p>		
r2050[0...19]	MODBUS PZD receive word	-	I16
	<p><b>Description:</b> Modbus PZD (setpoints) with word format received from the host controller.</p>		
	<p><b>Index:</b></p> <p>Index 0 to index 19 stand for PZD1 to PZD20 correspondingly.</p> <ul style="list-style-type: none"> <li>• [0]: Control word from host controller, the definition of control word refer to r2090.</li> <li>• [1]: In speed control mode, means speed setpoint from host controller.</li> <li>• [2] and [3]: In internal position control mode, means position setpoint(Hword/Lword) from host controller</li> <li>• [4] to [19]: Reserved.</li> </ul>		
r2090.0...15	MODBUS PZD1 receive bit-serial	-	U16
	<p><b>Description:</b> Bit-serial description of PZD1 (normally control word 1) received from the host controller.</p> <p>If the value of the bit equals to 0, it means the function of this bit is deactivated. If the value of the bit equals to 1, it means the function of this bit is activated.</p>		
r2122[0...63]	Alarm code	-	U16
	<p><b>Description:</b> Displays the number of faults that have occurred.</p>		
	<p><b>Dependency:</b> Refer to r2124</p>		
	<p><b>Note:</b> The buffer parameters are cyclically updated in the background.</p> <p>Alarm buffer structure (general principle):</p> <p>r2122[0], r2124[0] → alarm 1 (the oldest)</p> <p>...</p> <p>r2122[7], r2124[7] → alarm 8 (the latest)</p> <p>When the alarm buffer is full, the alarms that have gone are entered into the alarm history:</p> <p>r2122[8], r2124[8] → alarm 1 (the latest)</p> <p>...</p> <p>r2122[63], r2124[63] → alarm 1 (the oldest)</p>		

## 10.2 Parameter list

Par. No.	Name	Unit	Data type
r2124[0...6 3]	Alarm value	-	I32
	<b>Description:</b> Displays additional information about the active alarm (as integer number).		
	<b>Dependency:</b> Refer to r2124		
	<b>Note:</b> The buffer parameters are cyclically updated in the background. The structure of the alarm buffer and the assignment of the indices is shown in r2122.		
r2521[0...3 ]	LR position actual value	LU	I32
	<b>Description:</b> Displays the actual position actual value determined by the position actual value preprocessing.		
	<b>Index:</b>		
	<ul style="list-style-type: none"> <li>• [0]: CI-loop position control</li> <li>• [1]: Encoder 1</li> <li>• [2]: Encoder 2</li> <li>• [3]: Reserved</li> </ul>		
r2522[0...3 ]	LR velocity actual value	1000 LU/min	I32
	<b>Description:</b> Displays the actual position actual value determined by the velocity actual vaule preprocessing.		
	<b>Index:</b>		
	<ul style="list-style-type: none"> <li>• [0]: CI-loop position control</li> <li>• [1]: Encoder 1</li> <li>• [2]: Encoder 2</li> <li>• [3]: Reserved</li> </ul>		
r2556	LR position setpoint after setpoint smoothing	LU	I32
	<b>Description:</b> Display and connector output for the position setpoint after setpoint smoothing.		
r2563	LR following error dynamic model	LU	I32
	<b>Description:</b> Displays the dynamic following error. This value is the deviation, corrected by the velocity-dependent component, between the position setpoint and the position actual value.		
r2665	EPOS position setpoint	LU	I32
	<b>Description:</b> Displays the actual absolute position setpoint.		
r29015	PTI: Pulse input frequency	Hz	Float
	<b>Description:</b> Displays the PTI input pulse frequency.		
r29018[0... 1]	OA version	-	Float
	<b>Description:</b> Displays the OA version.		
	<b>Index:</b>		
r29400	Internal control signal status indicating	-	U32
	<b>Description:</b> Control signal status identifiers Bit 0 SON, Bit 1 RESET, Bit 2 CWL, Bit 3 CCWL, Bit 4 G-CHANGE, Bit 5 P-TRG, Bit 6 CLR, Bit 7 EGEAR1, Bit 8 EGEAR2, Bit 9 TLIM1, Bit 10 TLIM2, Bit 11 CWE, Bit 12 CCWE, Bit 13 ZSCLAMP, Bit 14 SPD1, Bit 15 SPD2, Bit 16 SPD3, Bit 17 TSET, Bit 18 SLIM1, Bit 19 SLIM2, Bit 20 POS1, Bit 21 POS2, Bit 22 POS3, Bit 23 REF, Bit 24 SREF, Bit 25 STEPFB, Bit 26 STEPB, Bit 27 STEPH, Bit 28 EMGS, Bit 29 C-MODE		

Par. No.	Name	Unit	Data type
r29942	DO signals status indicating	-	U32
	<b>Description:</b> Indicates the status of DO signals. <ul style="list-style-type: none"> <li>• Bit 0: RDY</li> <li>• Bit 1: FAULT</li> <li>• Bit 2: INP</li> <li>• Bit 3: ZSP</li> <li>• Bit 4: SPDR</li> <li>• Bit 5: TLR</li> <li>• Bit 6: SPLR</li> <li>• Bit 7: MBR</li> <li>• Bit 8: OLL</li> <li>• Bit 9: WARNING1</li> <li>• Bit 10: WARNING2</li> <li>• Bit 11: REFOK</li> <li>• Bit 12: CM_STA</li> <li>• Bit 13: RDY_ON</li> <li>• Bit 14: STO_EP</li> </ul>		
r29979	Index of actual electronic gear	-	U32
	<b>Description:</b> Displays the status of position loop. <ul style="list-style-type: none"> <li>• Bit 0 to Bit 1: Actual EGear index</li> </ul>		

# Diagnostics

## 11.1 Overview

### General information about faults and alarms



The errors and states detected by the individual components of the drive system are indicated by messages.

The messages are categorized into faults and alarms.

### Properties of faults and alarms

- Faults
  - Are identified by Fxxxx.
  - Can lead to a fault reaction.
  - Must be acknowledged once the cause has been remedied.
  - Status via control unit and LED RDY.
  - Status via MODBUS status word PZD1.1 (fault status).
  - Entry in the fault buffer.
- Alarms
  - Are identified by Axxxx.
  - Have no further effect on the drive.
  - The alarms are automatically reset once the cause has been remedied. No acknowledgement is required.
  - Status via Control Unit and LED RDY.
  - Entry in the alarm buffer.
- General properties of faults and alarms
  - Triggering on selected messages possible.
  - Contain the component number for identifying the affected SINAMICS component.
  - Contain diagnostic information on the relevant message.

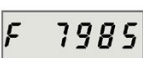
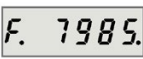
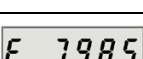
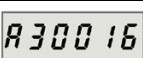
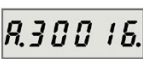
### Differences between faults and alarms

Type	BOP display (example)		Status indicator		Reaction	Acknowledgement
			RDY	COM		
Fault		Single fault	Slow flashing in red	-	<ul style="list-style-type: none"> <li>• <b>NONE:</b> no reaction</li> <li>• <b>OFF1:</b> servo motor ramps down</li> <li>• <b>OFF2:</b> servo motor coasts down</li> <li>• <b>OFF3:</b> servo motor stops quickly</li> <li>• <b>ENCODER:</b> Encoder fault causes OFF2.</li> </ul>	<ul style="list-style-type: none"> <li>• <b>POWER ON:</b> re-power on the servo drive to clear a fault after eliminating its cause.</li> <li>• <b>IMMEDIATELY:</b> the fault disappears immediately after eliminating its cause.</li> <li>• <b>PULSE INHIBIT:</b> The fault can only be acknowledged with a pulse inhibit. The same options are available for acknowledging as described under acknowledgment with IMMEDIATELY.</li> </ul>
		The first fault in the case of multiple faults				
		Non-first fault in the case of multiple faults				
Alarm		Single alarm	Slow flashing in red	-	<b>NONE:</b> no reaction	Self-acknowledgement
		The first alarm in the case of multiple alarms				
		Non-first alarm in the case of multiple alarms				

#### NOTICE

##### Faults are displayed in prior to alarms

If both faults and alarms occur, faults are displayed in prior to alarms. Alarms are displayed only after all faults have been acknowledged.

**BOP operations for faults and alarms**

To view faults or alarms, proceed as follows:

- Faults



- Alarms

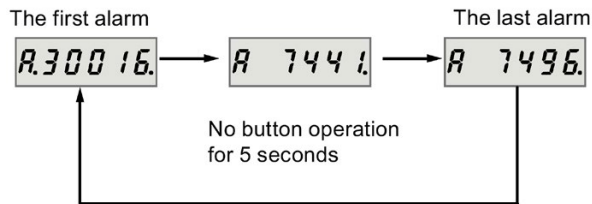

To exit from fault or alarm display, proceed as follows:

- Faults

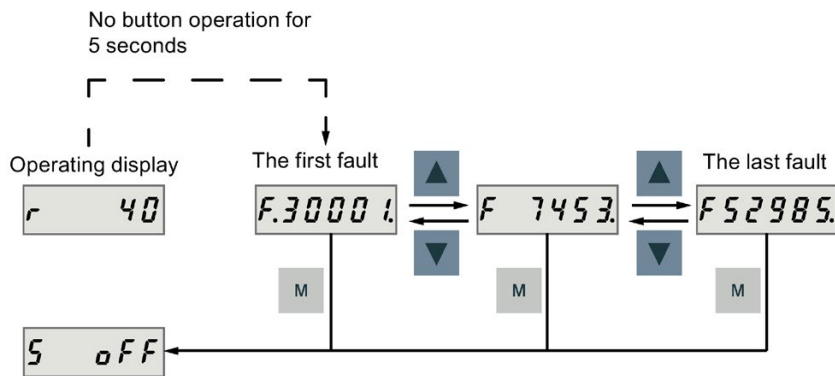

- Alarms

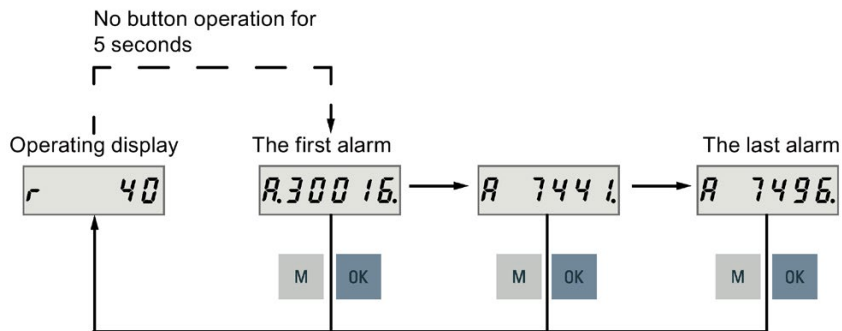

To acknowledge faults, proceed as follows:

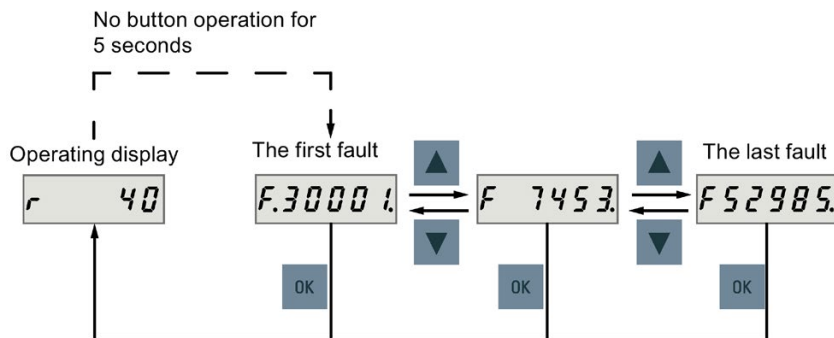

### Note

- If you do not eliminate the cause(s) of the fault, it can appear again after no button operation for five seconds. Make sure that you have eliminated the cause(s) of the fault.
- You can acknowledge faults using RESET signal. For details of the signal, refer to DIs (Page 107).
- You can acknowledge faults on the SINAMICS V-ASSISTANT. For details, refer to SINAMICS V-ASSISTANT Online Help.

## 11.2 List of faults and alarms

This section lists only common faults and alarms. To view the detailed information of all faults and alarms, call the online help for an active fault/alarm in the SINAMICS V-ASSISTANT engineering tool.

### Fault list

Fault	Cause	Remedy
<b>F1000: Internal software error</b> Reaction: OFF2 Acknowledgement: POWER ON	An internal software error has occurred.	<ul style="list-style-type: none"> <li>• Evaluate fault buffer.</li> <li>• Carry out a POWER ON (power off/on) for all components.</li> <li>• Upgrade firmware to later version.</li> <li>• Contact the Hotline.</li> <li>• Replace the Control Unit.</li> </ul>
<b>F1001: FloatingPoint exception</b> Reaction: OFF2 Acknowledgement: POWER ON	An exception occurred during an operation with the FloatingPoint data type.	<ul style="list-style-type: none"> <li>• Carry out a POWER ON (power off/on) for all components.</li> <li>• Upgrade firmware to the latest version.</li> <li>• Contact the Hotline.</li> </ul>

11.2 List of faults and alarms

Fault	Cause	Remedy
<p><b>F1002: Internal software error</b>                      Reaction: OFF2                      Acknowledgement: IMMEDIATELY</p>	<p>An internal software error has occurred.</p>	<ul style="list-style-type: none"> <li>• Carry out a POWER ON (power off/on) for all components.</li> <li>• Upgrade firmware to the latest version.</li> <li>• Contact the Hotline.</li> </ul>
<p><b>F1003: Acknowledgement delay when accessing the memory</b>                      Reaction: OFF2                      Acknowledgement: IMMEDIATELY</p>	<p>A memory area was accessed that does not return a "READY".</p>	<ul style="list-style-type: none"> <li>• Carry out a POWER ON (power off/on).</li> <li>• Contact the Hotline.</li> </ul>
<p><b>F1015: Internal software error</b>                      Reaction: OFF2                      Acknowledgement: POWER ON</p>	<p>An internal software error has occurred.</p>	<ul style="list-style-type: none"> <li>• Carry out a POWER ON (power off/on) for all components.</li> <li>• Upgrade firmware to the latest version.</li> <li>• Contact the Hotline.</li> </ul>
<p><b>F1018: Booting has been interrupted several times</b>                      Reaction: NONE                      Acknowledgement: POWER ON</p>	<p>Module booting was interrupted several times. As a consequence, the module boots with the factory setting.                      Possible reasons for booting being interrupted:</p> <ul style="list-style-type: none"> <li>• Power supply interrupted.</li> <li>• CPU crashed.</li> <li>• Parameterization invalid.</li> </ul> <p>After this fault is output, then the module is booted with the factory settings.</p>	<ul style="list-style-type: none"> <li>• Carry out a POWER ON (power off/on). After switching on, the module reboots from the valid parameterization (if available).</li> <li>• Restore the valid parameterization</li> </ul> <p>Examples:</p> <ul style="list-style-type: none"> <li>• Carry out a first commissioning, save, carry out a POWER ON (switch-off/switch-on).</li> <li>• Load another valid parameter backup (e.g. from the memory card), save, carry out a POWER ON (switch-off/switch-on).</li> </ul> <p>Note:                      If the fault situation is repeated, this fault is again output after several interrupted boots.</p>
<p><b>F1030: Sign-of-life failure for master control</b>                      Reaction: OFF3                      Acknowledgement: IMMEDIATELY</p>	<p>For active PC master control, no sign-of-life was received within the monitoring time.</p>	<p>Contact the Hotline.</p>
<p><b>F1611: SI CU: Defect detected</b>                      Reaction: OFF2                      Acknowledgement: IMMEDIATELY</p>	<p>The drive-integrated "Safety Integrated" (SI) function on the Control Unit (CU) has detected an error and initiated an STO</p>	<ul style="list-style-type: none"> <li>• Make sure that the high level duration of the input pulse is larger than 500 ms.</li> <li>• Carry out a POWER ON (power off/on) for all components.</li> <li>• Upgrade software.</li> <li>• Replace the Control Unit.</li> </ul>



Fault	Cause	Remedy
<b>F1910: Fieldbus: setpoint timeout</b> Reaction: OFF3 Acknowledgement: IMMEDIATELY	The reception of setpoints from the fieldbus interface (Modbus/USS) has been interrupted. <ul style="list-style-type: none"> <li>• Bus connection interrupted.</li> <li>• Controller switched off.</li> <li>• Controller set into the STOP state.</li> </ul>	Restore the bus connection and set the controller to RUN.
<b>F7011: Motor overtemperature</b> Reaction: OFF2 Acknowledgement: IMMEDIATELY	<ul style="list-style-type: none"> <li>• Motor overloaded</li> <li>• Motor surrounding temperature too high</li> <li>• Wire breakage or sensor not connected</li> <li>• Motor temperature model incorrectly parameterized</li> </ul>	<ul style="list-style-type: none"> <li>• Reduce the motor load.</li> <li>• Check the surrounding temperature and the motor ventilation.</li> <li>• Check the wiring and the connection.</li> <li>• Check the motor temperature model parameters.</li> </ul>
<b>F7085: Open-loop/closed-loop control parameters changed</b> Reaction: NONE Acknowledgement: IMMEDIATELY	Open-loop/closed-loop control parameters have had to be changed for the following reasons: <ul style="list-style-type: none"> <li>• As a result of other parameters, they have exceeded the dynamic limits.</li> <li>• They cannot be used due to the fact that the hardware detected not having certain features.</li> </ul>	It is not necessary to change the parameters as they have already been correctly limited.
<b>F7093: Drive: Test signal error</b> Reaction: OFF3 Acknowledgement: IMMEDIATELY	The limit rotation of the motor (p29027) is inappropriate.	Modify the value of parameter p29027.
<b>F7220: Drive: Master control by PLC missing</b> Reaction: OFF1 Acknowledgement: IMMEDIATELY	The "master control by PLC" signal was missing in operation. <ul style="list-style-type: none"> <li>• Input for "master control by PLC" is incorrect.</li> <li>• The higher-level control has withdrawn the "master control by PLC" signal.</li> <li>• Data transfer via the fieldbus (master/drive) was interrupted.</li> </ul>	<ul style="list-style-type: none"> <li>• Check the input for "master control by PLC".</li> <li>• Check the "master control by PLC" signal and, if required, switch in.</li> <li>• Check the data transfer via the fieldbus (master/drive).</li> </ul>
<b>F7403: Lower DC link voltage threshold reached</b> Reaction: OFF1 Acknowledgement: IMMEDIATELY	The DC link voltage monitoring is active and the lower DC link voltage threshold was reached in the "Operation" state.	<ul style="list-style-type: none"> <li>• Check the line supply voltage.</li> <li>• Check the infeed.</li> <li>• Reduce the lower DC link threshold.</li> <li>• Switch out (disable) the DC link voltage monitoring.</li> </ul>

11.2 List of faults and alarms

Fault	Cause	Remedy
<p><b>F7404: Upper DC link voltage threshold reached</b>                      Reaction: OFF2                      Acknowledgement: IMMEDIATELY</p>	<p>The DC link voltage monitoring is active and the upper DC link voltage threshold was reached in the "Operation" state.</p>	<ul style="list-style-type: none"> <li>• Check the line supply voltage.</li> <li>• Check the infeed module or the brake module.</li> <li>• Increase the upper DC link voltage threshold.</li> <li>• Switch out (disable) the DC link voltage monitoring.</li> </ul>
<p><b>F7410: Current controller output limited</b>                      Reaction: OFF2                      Acknowledgement: IMMEDIATELY</p>	<p>The condition "<math>I_{act} = 0</math> and <math>U_q_{set\_1}</math> longer than 16 ms at its limit" is present and can be caused by the following:</p> <ul style="list-style-type: none"> <li>• Motor not connected or motor contactor open.</li> <li>• No DC link voltage present.</li> <li>• Motor Module defective.</li> </ul>	<ul style="list-style-type: none"> <li>• Connect the motor or check the motor contactor.</li> <li>• Check the DC link voltage.</li> <li>• Check the Motor Module.</li> </ul>
<p><b>F7412: Commutation angle incorrect (motor model)</b>                      Reaction: ENCODER                      Acknowledgement: IMMEDIATELY</p>	<p>An incorrect commutation angle was detected that can result in a positive coupling in the speed controller.                      Possible causes:</p> <ul style="list-style-type: none"> <li>• The motor encoder is incorrectly adjusted with respect to the magnet position.</li> <li>• The motor encoder is damaged.</li> <li>• Data to calculate the motor model has been incorrectly set.</li> <li>• Pole position identification might have calculated an incorrect value when activated.</li> <li>• The motor encoder speed signal is faulted.</li> <li>• The control loop is instable due to incorrect parameterization.</li> </ul>	<ul style="list-style-type: none"> <li>• If the encoder mounting was changed, re-adjust the encoder.</li> <li>• Replace the defective motor encoder.</li> <li>• Correctly set the motor stator resistance, cable resistance and motor-stator leakage inductance.                      Calculate the cable resistance from the cross-section and length, check the inductance and stator resistance using the motor data sheet, measure the stator resistance, e.g. using a multimeter - and if required, again identify the values using the stationary motor data identification.</li> <li>• With pole position identification activated, check the procedure for pole position identification and force a new pole position identification procedure by means of de-selection followed by selection.</li> </ul>
<p><b>F7420: Drive: Current setpoint filter natural frequency &gt; Shannon frequency</b></p>	<p>One of the filter natural frequencies is greater than the Shannon frequency.</p>	<ul style="list-style-type: none"> <li>• Reduce the numerator or denominator natural frequency of the current setpoint filter involved.</li> <li>• Switch out the filter involved (p1656).</li> </ul>
<p><b>F7430: Changeover to open-loop torque controlled operation not possible</b>                      Reaction: OFF2                      Acknowledgement: POWER ON</p>	<p>For encoderless operation, the converter cannot change over to closed-loop torque-controlled operation.</p>	<ul style="list-style-type: none"> <li>• Do not attempt to change over to closed-loop torque-controlled operation.</li> <li>• Check the encoder cable connection.</li> </ul>

Fault	Cause	Remedy
<b>F7431: Changeover to encoderless operation not possible</b> Reaction: OFF2 Acknowledgement: POWER ON	For closed-loop torque control, the converter cannot change over to encoderless operation.	<ul style="list-style-type: none"> <li>Do not attempt to change over to encoderless operation.</li> <li>Check the encoder cable connection.</li> </ul>
<b>F7442: LR: Multiturn does not match the modulo range</b> Reaction: OFF1 (OFF2, OFF3) Acknowledgement: IMMEDIATELY	The ratio between the multiturn resolution and the modulo range (p29246) is not an integer number. This results in the adjustment being set back, as the position actual value cannot be reproduced after power-off/power-on.	Make the ration between the multiturn resolution and the modulo range an integer number. The ratio $v$ is calculated as follows: <ul style="list-style-type: none"> <li>Motor encoder without position tracking (p29243 = 0):               <ul style="list-style-type: none"> <li>For multiturn encoders:                   <math display="block">v = (4096 * p29247 * p29248)/(p29249 * p29246)</math> </li> <li>For singleturn encoders:                   <math display="block">v = (p29247 * p29248)/(p29249 * p29246)</math> </li> </ul> </li> <li>Motor encoder with position tracking (p29243 = 1):               <math display="block">v = (p29244 * 29247)/p29246</math> </li> </ul>
<b>F7443: Reference point coordinate not in the permissible range</b> Reaction: OFF1 (OFF2, OFF3) Acknowledgement: IMMEDIATELY	The reference point coordinate received when adjusting the encoder via connector input p2599 lies outside the half of the encoder range and cannot be set as actual axis position.  Fault value (r0949, interpret decimal): Maximum permissible value for the reference point coordinate.	Set the reference point coordinate to a lower value than specified in the fault value.  See also: p2599 (EPOS reference point coordinate value).  For a motor with an absolute encoder, the maximum permissible encoder range is calculated by the following formula: <ul style="list-style-type: none"> <li>For multiturn encoders:               <math display="block">(4096 * p29247) / 2</math> </li> <li>For singleturn encoders:               <math display="block">p29247 / 2</math> </li> </ul>
<b>F7447: Load gear: Position tracking, maximum actual value exceeded</b> Message class: Application/technological function faulted (17) Reaction: NONE Acknowledgement: IMMEDIATELY	When the position tracking of the load gear is configured, the drive/encoder (motor encoder) identifies a maximum possible absolute position actual that can no longer be represented within 32 bits.  Maximum value: encoder resolution ( $2^{20}$ or $2^{21}$ ) $\times$ p29244	Reduce the multi-turn resolution (p29244).

11.2 List of faults and alarms

Fault	Cause	Remedy
<p><b>F7449: Load gear: Position tracking actual position outside tolerance window</b>                      Message class: Application/technological function faulted (17)                      Reaction: OFF1                      Acknowledgement: IMMEDIATELY</p>	<p>When switched off, the currently effective motor encoder was moved through a distance greater than was parameterized in the tolerance window. It is possible that there is no longer any reference between the mechanical system and encoder.                      Fault value (r0949, interpret decimal):                      Deviation (difference) to the last encoder position in increments of the absolute value after the measuring gear - if one is being used. The sign designates the traversing direction.                      Note: The deviation (difference) window is pre-assigned quarter of the encoder range.</p>	<p>Reactivate the position tracking function (set p29243 = 1 → 0 → 1). Then the fault is acknowledged and, if necessary, adjust the encoder encoder (ABS).</p>
<p><b>F7450: Standstill monitoring has responded</b>                      Reaction: OFF1                      Acknowledgement: IMMEDIATELY</p>	<p>After the standstill monitoring time expired, the drive left the standstill window.</p> <ul style="list-style-type: none"> <li>• Position loop gain too low.</li> <li>• Position loop gain too high (instability/oscillation).</li> <li>• Mechanical overload.</li> <li>• Connecting cable, motor/drive converter incorrect (phase missing, interchange).</li> </ul>	<p>Check the causes and resolve.</p>
<p><b>F7451: Position monitoring has responded</b>                      Reaction: OFF1                      Acknowledgement: IMMEDIATELY</p>	<p>When the position monitoring time (p2545) expired, the drive had still not reached the positioning window (p2544).</p> <ul style="list-style-type: none"> <li>• Positioning window parameterized too small (p2544).</li> <li>• Position monitoring time parameterized too short (p2545).</li> <li>• Position loop gain is too low.</li> <li>• Position loop gain is too high (instability/oscillation).</li> <li>• Drive mechanically locked.</li> </ul>	<p>Check the causes and resolve.</p>
<p><b>F7452: Following error too high</b>                      Reaction: OFF1                      Acknowledgement: IMMEDIATELY</p>	<p>The difference between the position setpoint and position actual value (following error dynamic model) is greater than the tolerance (p2546).</p> <ul style="list-style-type: none"> <li>• The value of p2546 is too small.</li> <li>• The gain of position loop is too small.</li> <li>• The drive torque or accelerating capacity exceeded.</li> <li>• Position measuring system fault.</li> <li>• Position control sense incorrect.</li> <li>• Mechanical system locked.</li> <li>• Excessively high traversing velocity or excessively high position reference value (setpoint) differences.</li> </ul>	<p>Check the causes and resolve.</p>

Fault	Cause	Remedy
<b>F7453: Position actual value preprocessing error</b> Reaction: OFF2 Acknowledgement: IMMEDIATELY	An error has occurred during the position actual value preprocessing.	Check the encoder for the position actual value preprocessing.
<b>F7458: EPOS: Reference cam not found</b> Reaction: OFF1 (OFF2, OFF3) Acknowledgement: IMMEDIATELY	After starting the search for reference, the axis moved through the maximum permissible distance to search for the reference cam without actually finding the reference cam.	<ul style="list-style-type: none"> <li>• Check the "reference cam" input.</li> <li>• Check the maximum permissible distance to the reference cam (p2606).</li> </ul> See also: p2606 (EPOS search for reference reference cam maximum distance)
<b>F7459: Zero mark not detected</b> Reaction: OFF1 Acknowledgement: IMMEDIATELY	After leaving the reference cam, the axis has traversed the maximum permissible distance (p2609) between the reference cam and the zero mark without finding the zero mark.	<ul style="list-style-type: none"> <li>• Check the encoder regarding zero mark.</li> <li>• Check the maximum permissible distance between the reference cam and zero mark (p2609).</li> <li>• Use an external encoder zero mark (equivalent zero mark).</li> </ul> See also: p2609 (EPOS search for reference max distance ref cam and zero mark)
<b>F7460: EPOS: End of reference cam not found</b> Reaction: OFF1 (OFF2, OFF3) Acknowledgement: IMMEDIATELY	During the search for reference, when the axis reached the zero mark it also reached the end of the traversing range without detecting an edge at the binector input "reference cam".  Maximum traversing range: -2147483648 [LU] ... -2147483647 [LU]	<ul style="list-style-type: none"> <li>• Check the "reference cam" input.</li> <li>• Repeat the search for reference.</li> </ul>
<b>F7464: EPOS: Traversing block is inconsistent</b> Reaction: OFF1 (OFF2, OFF3) Acknowledgement: IMMEDIATELY	The traversing block does not contain valid information.  Alarm value: Number of the traversing block with invalid information.	Check the traversing block and where relevant, take into consideration alarms that are present.
<b>F7475: EPOS: Target position &lt; start of traversing range</b> Reaction: OFF1 (OFF2, OFF3) Acknowledgement: IMMEDIATELY	The target position for relative traversing lies outside the traversing range.	Correct the target position.
<b>F7476: EPOS: Target position &gt; end of the traversing range</b> Reaction: OFF1 (OFF2, OFF3) Acknowledgement: IMMEDIATELY	The target position for relative traversing lies outside the traversing range.	Correct the target position.

Fault	Cause	Remedy
<b>F7481: EPOS: Axis position &lt; software limit switch minus</b> Reaction: OFF1 (OFF2, OFF3) Acknowledgement: IMMEDIATELY	The actual position of the axis is less than the position of the software limit switch minus.	<ul style="list-style-type: none"> <li>Correct the target position.</li> <li>Change software limit switch minus (CI: p2580).</li> </ul>
<b>F7482: EPOS: Axis position &gt; software limit switch plus</b> Reaction: OFF1 (OFF2, OFF3) Acknowledgement: IMMEDIATELY	The actual position of the axis is greater than the position of the software limit switch plus.	<ul style="list-style-type: none"> <li>Correct the target position.</li> <li>Change software limit switch plus (CI: p2581).</li> </ul>
<b>F7484: Fixed stop outside the monitoring window</b> Reaction: OFF1 (OFF2, OFF3) Acknowledgement: IMMEDIATELY	In the "fixed stop reached" state, the axis has moved outside the defined monitoring window (p2635).	<ul style="list-style-type: none"> <li>Check the monitoring window (p2635).</li> <li>Check the mechanical system.</li> </ul>
<b>F7485: Fixed stop not reached</b> Reaction: OFF1 (OFF2, OFF3) Acknowledgement: IMMEDIATELY	In a traversing block with the task FIXED STOP, the end position was reached without detecting a fixed stop.	<ul style="list-style-type: none"> <li>Check the traversing block and locate the target position further into the workpiece.</li> <li>Check the "fixed stop reached" control signal.</li> <li>If required, reduce the maximum following error window to detect the fixed stop (p2634).</li> </ul>
<b>F7488: EPOS: Relative positioning not possible</b> Reaction: OFF1 (OFF2, OFF3) Acknowledgement: IMMEDIATELY	In the mode "direct setpoint input/MDI", for continuous transfer relative positioning was selected.	Check the control.
<b>F7490: Enable signal withdrawn while traversing</b> Reaction: OFF1 Acknowledgement: IMMEDIATELY	<ul style="list-style-type: none"> <li>For a standard assignment, another fault may have occurred as a result of withdrawing the enable signals.</li> <li>The drive is in the "switching on inhibited" state (for a standard assignment).</li> </ul>	<ul style="list-style-type: none"> <li>Set the enable signals or check the cause of the fault that first occurred and then result (for a standard assignment).</li> <li>Check the assignment to enable the basic positioning function.</li> </ul>
<b>F7491: STOP cam minus reached</b> Reaction: OFF3 Acknowledgement: IMMEDIATELY	The STOP cam minus was reached. For a positive traversing direction, the STOP cam minus was reached, i.e. the wiring of the STOP cam is incorrect.	<ul style="list-style-type: none"> <li>Leave the STOP cam minus in the positive traversing direction and return the axis to the valid traversing range.</li> <li>Check the wiring of the STOP cam.</li> </ul>
<b>F7492: STOP cam plus reached</b> Reaction: OFF3 Acknowledgement: IMMEDIATELY	The STOP cam plus was reached. For a negative traversing direction, the STOP cam plus was reached, i.e. the wiring of the STOP cam is incorrect.	<ul style="list-style-type: none"> <li>Leave the STOP cam plus in the negative traversing direction and return the axis to the valid traversing range.</li> <li>Check the wiring of the STOP cam.</li> </ul>

Fault	Cause	Remedy
<p><b>F7493: LR: Overflow of the value range for position actual value</b></p> <p>Reaction: OFF1 (OFF2, OFF3)</p> <p>Acknowledgement: IMMEDIATELY</p>	<p>The value range (-2147483648 ... 2147483647) for the position actual value representation was exceeded. When the overflow occurs, the "referenced" or "adjustment absolute measuring system" status is reset.</p> <ul style="list-style-type: none"> <li>• The position actual value (r2521) has exceeded the value range.</li> <li>• The encoder position actual value has exceeded the value range.</li> <li>• The maximum encoder value times the factor to convert the absolute position from increments to length units (LU) has exceeded the value range for displaying the position actual value.</li> </ul>	<p>If required, reduce the traversing range or position resolution p29247.</p> <p>Note for case = 3:</p> <p>If the value for the maximum possible absolute position (LU) is greater than 4294967296, then it is not possible to make an adjustment due to an overflow.</p> <p>For rotary encoders, the maximum possible absolute position (LU) is calculated as follows:</p> <p>Motor encoder with position tracking:</p> <ul style="list-style-type: none"> <li>• IPos: <math>p29247 * p29244</math></li> <li>• PTI: <math>1048576 * p29012[X] * p29244 / p29013</math></li> </ul> <p>Motor encoder without position tracking:</p> <ul style="list-style-type: none"> <li>• For multiturn encoders: <ul style="list-style-type: none"> <li>– IPos: <math>p29247 * p29248 * 4096 / p29249</math></li> <li>– PTI: <math>1048576 * p29012[X] * 4096 / p29013</math></li> </ul> </li> <li>• For singleturn encoders: <ul style="list-style-type: none"> <li>– IPos: <math>p29247 * p29248 / p29249</math></li> <li>– PTI: <math>1048576 * p29012[X] / p29013</math></li> </ul> </li> </ul>
<p><b>F7599: Encoder 1: Adjustment not possible</b></p> <p>Reaction: OFF1 (NONE, OFF2, OFF3)</p> <p>Acknowledgement: IMMEDIATELY</p>	<p>The maximum encoder value times the factor to convert the absolute position from increments to length units (LU) has exceeded the value range (-2147483648 ... 2147483647) for displaying the position actual value.</p>	<p>If the value for the maximum possible absolute position (LU) is greater than 4294967296, then it is not possible to make an adjustment due to an overflow.</p> <p>For rotary encoders, the maximum possible absolute position (LU) is calculated as follows:</p> <p>Motor encoder with position tracking:</p> <ul style="list-style-type: none"> <li>• IPos: <math>p29247 * p29244</math></li> <li>• PTI: <math>1048576 * p29012[X] * p29244 / p29013</math></li> </ul> <p>Motor encoder without position tracking:</p> <ul style="list-style-type: none"> <li>• For multiturn encoders: <ul style="list-style-type: none"> <li>– IPos: <math>p29247 * p29248 * 4096 / p29249</math></li> <li>– PTI: <math>1048576 * p29012[X] * 4096 / p29013</math></li> </ul> </li> <li>• For singleturn encoders: <ul style="list-style-type: none"> <li>– IPos: <math>p29247 * p29248 / p29249</math></li> <li>– PTI: <math>1048576 * p29012[X] / p29013</math></li> </ul> </li> </ul>

11.2 List of faults and alarms

Fault	Cause	Remedy
<p><b>F7800 Drive: No power unit present</b>                      Reaction: NONE                      Acknowledgement: IMMEDIATELY</p>	<p>The power unit parameters cannot be read or no parameters are stored in the power unit.</p>	<ul style="list-style-type: none"> <li>• Carry out a POWER ON (power off/on) for all components.</li> <li>• Change the module.</li> </ul>
<p><b>F7801: Motor overcurrent</b>                      Reaction: OFF2                      Acknowledgement: IMMEDIATELY</p>	<p>The permissible motor limit current was exceeded.</p> <ul style="list-style-type: none"> <li>• Effective current limit set too low.</li> <li>• Current controller not correctly set.</li> <li>• Motor was braked with an excessively high stall torque correction factor.</li> <li>• Up ramp was set too short or the load is too high.</li> <li>• Short-circuit in the motor cable or ground fault.</li> <li>• Motor current does not match the current of Motor Module.</li> </ul>	<ul style="list-style-type: none"> <li>• Reduce the stall torque correction factor.</li> <li>• Increase the up ramp or reduce the load.</li> <li>• Check the motor and motor cables for short-circuit and ground fault.</li> <li>• Check the Motor Module and motor combination.</li> </ul>
<p><b>F7802: Infeed or power unit not ready</b>                      Reaction: OFF2                      Acknowledgement: IMMEDIATELY</p>	<p>After an internal power-on command, the infeed or drive does not signal ready because of one of the following reasons:</p> <ul style="list-style-type: none"> <li>• Monitoring time is too short.</li> <li>• DC link voltage is not present.</li> <li>• Associated infeed or drive of the signaling component is defective.</li> </ul>	<ul style="list-style-type: none"> <li>• Ensure that there is a DC link voltage. Check the DC link busbar. Enable the infeed.</li> <li>• Replace the associated infeed or drive of the signaling component.</li> </ul>
<p><b>F7815: Power unit has been changed</b>                      Reaction: NONE                      Acknowledgement: IMMEDIATELY</p>	<p>The code number of the actual power unit does not match the saved number.</p>	<p>Connect the original power unit and power up the Control Unit again (POWER ON).</p>
<p><b>F7900: Motor blocked/speed controller at its limit</b>                      Reaction: OFF2                      Acknowledgement: IMMEDIATELY</p>	<p>The servo motor has been operating at the torque limit longer than the delay time (p2177) and below the speed threshold (p2175).                      This signal can also be initiated if the speed actual value is oscillating and the speed controller output repeatedly goes to its limit.</p>	<ul style="list-style-type: none"> <li>• Check whether the servo motor can rotate freely or not.</li> <li>• Check the torque limit.</li> <li>• Check the inversion of the actual value.</li> <li>• Check the motor encoder connection.</li> <li>• Check the encoder pulse number.</li> </ul>
<p><b>F7901: Motor overspeed</b>                      Reaction: OFF2                      Acknowledgement: IMMEDIATELY</p>	<ul style="list-style-type: none"> <li>• The maximumly permissible speed has been exceeded.</li> <li>• The speed limit has been exceeded.</li> </ul>	<ul style="list-style-type: none"> <li>• Check and correct the maximum speed (p1082).</li> <li>• Check and correct the speed limit (p29070, p29071), and the DI signals SLIM1 and SLIM2.</li> <li>• Check if there are any peaks of actual speed. If the value of the peak is especially large, contact the hotline.</li> </ul>



Fault	Cause	Remedy
<b>F7995: Motor identification failure</b> Reaction: OFF2 Acknowledgement: IMMEDIATELY	For incremental motor, needs pole position identification when first SON. If the motor already in run (i.e. by external force) position identification may failure.	Stop the motor before servo on.
<b>F30001: Power unit: Overcurrent</b> Reaction: OFF2 Acknowledgement: IMMEDIATELY	The power unit has detected an overcurrent condition. <ul style="list-style-type: none"> <li>• Closed-loop control is incorrectly parameterized.</li> <li>• Controller parameters are not proper.</li> <li>• Motor has a short-circuit or fault to ground (frame).</li> <li>• Power cables are not correctly connected.</li> <li>• Power cables exceed the maximum permissible length.</li> <li>• Power unit defective.</li> <li>• Line phase interrupted.</li> </ul>	<ul style="list-style-type: none"> <li>• Check the motor data - if required, carry out commissioning.</li> <li>• Modify speed loop Kp (p29120), position loop Kv (p29110).</li> <li>• Check the motor circuit configuration (star-delta).</li> <li>• Check the power cable connections.</li> <li>• Check the power cables for short-circuit or ground fault.</li> <li>• Check the length of the power cables.</li> <li>• Replace power unit.</li> <li>• Check the line supply phases.</li> <li>• Check the external braking resistor connection.</li> </ul>
<b>F30002: DC link voltage, overvoltage</b> Reaction: OFF2 Acknowledgement: IMMEDIATELY	The power unit has detected overvoltage in the DC link. <ul style="list-style-type: none"> <li>• Motor regenerates too much energy.</li> <li>• Device connection voltage too high.</li> <li>• Line phase interrupted.</li> </ul>	<ul style="list-style-type: none"> <li>• Increase the ramp-down time.</li> <li>• Activate the DC link voltage controller.</li> <li>• Use a braking resistor.</li> <li>• Increase the current limit of the infeed or use a larger module.</li> <li>• Check the device supply voltage.</li> <li>• Check the line supply phases.</li> </ul>
<b>F30003: DC link voltage, undervoltage</b> Reaction: OFF2 Acknowledgement: IMMEDIATELY	The power unit has detected an undervoltage condition in the DC link. <ul style="list-style-type: none"> <li>• Line supply failure</li> <li>• Line supply voltage below the permissible value.</li> <li>• Line supply infeed failed or interrupted.</li> <li>• Line phase interrupted.</li> </ul>	<ul style="list-style-type: none"> <li>• Check the line supply voltage</li> <li>• Check the line supply infeed and observe the fault messages relating to it (if there are any)</li> <li>• Check the line supply phases.</li> <li>• Check the line supply voltage setting.</li> </ul>
<b>F30004: Drive heat sink overtemperature</b> Reaction: OFF2 Acknowledgement: IMMEDIATELY	The temperature of the power unit heat sink has exceeded the permissible limit value. <ul style="list-style-type: none"> <li>• Insufficient cooling, fan failure.</li> <li>• Overload.</li> <li>• Surrounding temperature too high.</li> <li>• Pulse frequency too high.</li> </ul>	<ul style="list-style-type: none"> <li>• Check whether the fan is running.</li> <li>• Check the fan elements.</li> <li>• Check whether the surrounding temperature is in the permissible range.</li> <li>• Check the motor load.</li> <li>• Reduce the pulse frequency if this is higher than the rated pulse frequency.</li> </ul>
<b>F30005: Power unit: Overload I<sub>2t</sub></b> Reaction: OFF2 Acknowledgement: IMMEDIATELY	The power unit was overloaded. <ul style="list-style-type: none"> <li>• The permissible rated power unit current was exceeded for an inadmissibly long time.</li> <li>• The permissible load duty cycle was not maintained.</li> </ul>	<ul style="list-style-type: none"> <li>• Reduce the continuous load.</li> <li>• Adapt the load duty cycle.</li> <li>• Check the motor and power unit rated currents.</li> </ul>

11.2 List of faults and alarms

Fault	Cause	Remedy
<p><b>F30011: Line phase failure in main circuit</b>                      Reaction: OFF2                      Acknowledgement: IMMEDIATELY</p>	<p>At the power unit, the DC link voltage ripple has exceeded the permissible limit value.                      Possible causes:</p> <ul style="list-style-type: none"> <li>• A line phase has failed.</li> <li>• The 3 line phases are inadmissibly unsymmetrical.</li> <li>• The fuse of a phase of a main circuit has ruptured.</li> <li>• A motor phase has failed.</li> </ul>	<ul style="list-style-type: none"> <li>• Check the main circuit fuses.</li> <li>• Check whether a single-phase load is distorting the line voltages.</li> <li>• Check the motor feeder cables.</li> </ul>
<p><b>F30015: Phase failure motor cable</b>                      Reaction: OFF2                      Acknowledgement: IMMEDIATELY</p>	<p>A phase failure in the motor feeder cable was detected.                      The signal can also be output in the following case:                      The motor is correctly connected, however the closed-speed control is instable and therefore an oscillating torque is generated.</p>	<ul style="list-style-type: none"> <li>• Check the motor feeder cables.</li> <li>• Check the speed controller settings.</li> </ul>
<p><b>F30021: Ground fault</b>                      Reaction: OFF2                      Acknowledgement: IMMEDIATELY</p>	<p>Power unit has detected a ground fault.</p> <ul style="list-style-type: none"> <li>• Ground fault in the power cables.</li> <li>• Winding fault or ground fault at the motor.</li> </ul>	<ul style="list-style-type: none"> <li>• Check the power cable connections.</li> <li>• Check the motor.</li> </ul>
<p><b>F30027: Precharging DC link time monitoring</b>                      Reaction: OFF2                      Acknowledgement: IMMEDIATELY</p>	<ul style="list-style-type: none"> <li>• The power unit DC link was not able to be pre-charged within the expected time.                              There is no line supply voltage connected.</li> <li>• The line contactor/line side switch has not been closed.</li> <li>• The line supply voltage is too low.</li> <li>• The pre-charging resistors are overheated as there were too many pre-charging operations per time unit</li> <li>• The pre-charging resistors are overheated as the DC link capacitance is too high.</li> <li>• The pre-charging resistors are overheated.</li> <li>• The pre-charging resistors are overheated as the line contactor was closed during the DC link fast discharge through the Braking Module.</li> <li>• The DC link has either a ground fault or a short-circuit.</li> <li>• The pre-charging circuit is possibly defective.</li> </ul>	<p>Check the line supply voltage at the input terminals.</p>

Fault	Cause	Remedy
<b>F30036: Internal overtemperature</b> Reaction: OFF2 Acknowledgement: IMMEDIATELY	The temperature inside the drive converter has exceeded the permissible temperature limit. <ul style="list-style-type: none"> <li>Insufficient cooling, fan failure.</li> <li>Overload.</li> <li>Surrounding temperature too high.</li> </ul>	<ul style="list-style-type: none"> <li>Check whether the fan is running.</li> <li>Check the fan elements.</li> <li>Check whether the surrounding temperature is in the permissible range.</li> </ul> Notice: This fault can only be acknowledged once the permissible temperature limit minus 5 K has been fallen below.
<b>F30050: 24 V supply overvoltage</b> Reaction: OFF2 Acknowledgement: POWER ON	The voltage monitor signals an overvoltage fault on the module.	<ul style="list-style-type: none"> <li>Check the 24 V power supply.</li> <li>Replace the module if necessary.</li> </ul>
<b>F30071: No new actual values received from the power unit</b> Reaction: OFF2 Acknowledgement: IMMEDIATELY	The number of actual value telegrams from the power unit that have failed has exceeded the permissible number.	Replace the module if necessary.
<b>F31100: Zero mark distance error</b> Reaction: ENCODER Acknowledgement: PULSE INHIBIT	The measured zero mark distance does not correspond to the parameterized zero mark distance. For distance-coded encoders, the zero mark distance is determined from zero marks detected pairs. This means that if a zero mark is missing, depending on the pair generation, this cannot result in a fault and also has no effect in the system.	<ul style="list-style-type: none"> <li>Check that the encoder cables are routed in compliance with EMC.</li> <li>Check the plug connections</li> <li>Replace the encoder or encoder cable</li> </ul>
<b>F31101: Zero mark failed</b> Reaction: ENCODER Acknowledgement: PULSE INHIBIT	The 1.5 x parameterized zero mark distance was exceeded.	<ul style="list-style-type: none"> <li>Check that the encoder cables are routed in compliance with EMC.</li> <li>Check the plug connections.</li> <li>Replace the encoder or encoder cable.</li> </ul>
<b>F31110: Serial communications error</b> Reaction: ENCODER Acknowledgement: PULSE INHIBIT	Serial communication protocol transfer error between the encoder and evaluation module.	<ul style="list-style-type: none"> <li>Check the encoder cable and shielding connection.</li> <li>Replace the encoder cable/encoder.</li> </ul>
<b>F31111: Encoder 1: Absolute encoder internal error</b> Reaction: ENCODER Acknowledgement: PULSE INHIBIT	The absolute encoder fault word supplies fault bits that have been set.	<ul style="list-style-type: none"> <li>Check the encoder cable connection and make sure the cables are routed in compliance with EMC.</li> <li>Check the motor temperature.</li> <li>Replace the motor/encoder.</li> </ul>
<b>F31112: Error bit set in the serial protocol</b> Reaction: ENCODER Acknowledgement: PULSE INHIBIT	The encoder sends a set error bit via the serial protocol.	Refer to F31111.

11.2 List of faults and alarms

Fault	Cause	Remedy
<p><b>F31117: Inversion error signals A/B/R</b>                      Reaction: ENCODER                      Acknowledgement: PULSE INHIBIT</p>	<p>For a square-wave encoder (bipolar, double ended) signals A*, B* and R* are not inverted with respect to signals A, B and R.</p>	<ul style="list-style-type: none"> <li>• Check the encoder and cable and the connection of them.</li> <li>• Does the encoder supply signals and the associated inverted signals?</li> </ul>
<p><b>F31130: Zero mark and position error from the coarse synchronization</b>                      Reaction: ENCODER                      Acknowledgement: PULSE INHIBIT</p>	<p>After initializing the pole position using track C/D, Hall signals or pole position identification routine, the zero mark was detected outside the permissible range. For distance-coded encoders, the test is carried out after passing 2 zero marks. Fine synchronization was not carried out.</p>	<ul style="list-style-type: none"> <li>• Check that the encoder cables are routed in compliance with EMC.</li> <li>• Check the plug connections</li> <li>• If the Hall sensor is used as an equivalent for track C/D, check the connection.</li> <li>• Check the connection of track C or D.</li> <li>• Replace the encoder or encoder cable.</li> </ul>
<p><b>F31131: Encoder 1: Deviation position incremental/absolute too large</b>                      Reaction: ENCODER                      Acknowledgement: PULSE INHIBIT</p>	<ul style="list-style-type: none"> <li>• Absolute encoder                              When cyclically reading the absolute position, an excessively high difference to the incremental position was detected. The absolute position that was read is rejected.                               Limit value for the deviation: 15 pulses (60 quadrants).</li> <li>• Incremental encoder                              When the zero is passed, a deviation in the incremental position was detected.                               The first zero mark passed supplies the reference point for all subsequent checks. The other zero marks must have n times the distance referred to the first zero mark.                               Deviation in quadrants (1 pulse = 4 quadrants).</li> </ul>	<ul style="list-style-type: none"> <li>• Check that the encoder cables are routed in compliance with EMC.</li> <li>• Check the plug connections.</li> <li>• Replace the encoder or encoder cable.</li> <li>• Check whether the coding disk is dirty or there are strong ambient magnetic fields.</li> </ul>
<p><b>F31150: Initialization error</b>                      Reaction: ENCODER                      Acknowledgement: PULSE INHIBIT</p>	<p>Encoder functionality is not operating correctly.</p>	<ul style="list-style-type: none"> <li>• Check the encoder type used (incremental/absolute) and the encoder cable.</li> <li>• If relevant, note additional fault messages that describe the fault in detail.</li> </ul>
<p><b>F52903: Fault inconsistency between fault status and fault buffer</b>                      Reaction: OFF2                      Acknowledgement: IMMEDIATELY</p>	<p>Fault status and fault number buffer are inconsistent.</p>	<p>Repower on.</p>
<p><b>F52904: Control mode change</b>                      Reaction: OFF2                      Acknowledgement: POWER ON</p>	<p>When the control mode is changed, the drive must be saved and restarted.</p>	<p>Save and restart the drive.</p>

Fault	Cause	Remedy
<b>F52911: Positive torque limitation value error</b> Reaction: OFF2 Acknowledgement: IMMEDIATELY	One of positive torque limitation values (p29050, p1520) becomes less than 0.	Configure all of positive torque limitation values (p29050, p1520) not less than 0.
<b>F52912: Negative torque limitation value error</b> Reaction: OFF2 Acknowledgement: IMMEDIATELY	One of negative torque limitation values (p29051, p1521) becomes greater than 0.	Configure all of negative torque limitation values (p29051, 1521) not greater than 0.
<b>F52931: Gear box limit</b> Reaction: OFF1 Acknowledgement: IMMEDIATELY	The electronic gear ratio (p29012[x] / p29013[x]) exceeds the range from 0.02 to 200.	Adjust the electronic gear ratio within the permissible range from 0.02 to 200.
<b>F52933: PTO gear box limit</b> Reaction: OFF1 Acknowledgement: IMMEDIATELY	The electronic gear ratio (p29031[0] / p29032[0]) exceeds the range from 0.02 to 200.	Adjust the electronic gear ratio within the permissible range from 0.02 to 200.
<b>F52980: Absolute encoder motor changed</b> Reaction: OFF1 Acknowledgement: IMMEDIATELY	The servo motor with an absolute encoder is changed. For example, the actual motor ID is different from the commissioned motor ID.	The servo motor will be automatically configured after the following measures have been implemented: <ul style="list-style-type: none"> <li>Acknowledge the fault firstly and then save the newly commissioned parameters to the drive ROM</li> </ul>
<b>F52981: Absolute encoder motor mismatched</b> Reaction: OFF1 Acknowledgement: IMMEDIATELY	Connected absolute encoder motor cannot be operated. The servo drive in use does not support the Motor ID.	Use a suitable absolute encoder motor.
<b>F52983: No encoder detected</b> Reaction: OFF1 Acknowledgement: IMMEDIATELY	The servo drive in use does not support encoderless operation.	<ul style="list-style-type: none"> <li>Check the encoder cable connection between the servo drive and the servo motor.</li> <li>Use a servo motor with encoder.</li> </ul>
<b>F52984: Incremental encoder motor not configured</b> Reaction: OFF1 Acknowledgement: IMMEDIATELY	<ul style="list-style-type: none"> <li>Commissioning of the servo motor has failed.</li> <li>The incremental encoder motor is connected but fails to commission.</li> </ul>	Configure the motor ID by setting the parameter p29000.
<b>F52985: Absolute encoder motor wrong</b> Reaction: OFF1 Acknowledgement: IMMEDIATELY	<ul style="list-style-type: none"> <li>Motor ID is downloaded wrong during manufacture.</li> <li>The firmware of the servo drive does not support the Motor ID.</li> </ul>	<ul style="list-style-type: none"> <li>Update the firmware.</li> <li>Use a correct absolute encoder motor.</li> </ul>
<b>F52987: Absolute encoder replaced</b> Reaction: OFF1 Acknowledgement: IMMEDIATELY	Incorrect absolute encoder data.	Contact the Hotline.

Alarm list

Alarm	Cause	Remedy
<b>A1009: Control module over-temperature</b>	The temperature of the control module (Control Unit) has exceeded the specified limit value.	<ul style="list-style-type: none"> <li>• Check the air intake for the Control Unit.</li> <li>• Check the Control Unit fan.</li> </ul> <p>Note: The alarm automatically disappears after the limit value has been undershot.</p>
<b>A1019: Writing to the removable data medium unsuccessful</b>	The write access to the removable data medium was unsuccessful.	Remove and check the removable data medium. Then run the data backup again.
<b>A1032: All parameters must be saved</b>	The parameters of an individual drive object were saved, although there is still no backup of all drive system parameters. The saved object-specific parameters are not loaded the next time that the system powers up. For the system to successfully power up, all of the parameters must have been completely backed up.	Save all parameters.
<b>A1045: Configuring data invalid</b>	An error was detected when evaluating the parameter files saved in the non-volatile memory. Because of this, under certain circumstances, several of the saved parameter values were not able to be accepted.	Save the parameterization in SINAMICS V-ASSISTANT using the "Copy RAM to ROM" function or on the BOP. This overwrites the incorrect parameter files in the non-volatile memory – and the alarm is withdrawn.
<b>A1774: Test stop for fail-safe digital outputs required</b>	<p>The preset time for the forced checking procedure (test stop) for the fail-safe digital outputs (F-DO) has been exceeded. A new forced checking procedure is required.</p> <p><b>Note:</b></p> <ul style="list-style-type: none"> <li>• This message does not result in a safety stop response.</li> <li>• The test must be performed within a defined maximum time interval (maximum of 8760 hours) in order to comply with the requirements as laid down in the standards for timely fault detection and the conditions to calculate the failure rates of safety functions (PFH value). Operation beyond this maximum time period is permissible if it can be ensured that the forced checking procedure is performed before persons enter the hazardous area and who are depending on the safety functions correctly functioning.</li> </ul>	Carry out the forced checking procedure for the digital outputs.

Alarm	Cause	Remedy
<b>A1920: Drive Bus: Receive setpoints after To</b>	Output data of Drive Bus master (set-points) received at the incorrect instant in time within the Drive Bus clock cycle.	<ul style="list-style-type: none"> <li>Check bus configuration.</li> <li>Check parameters for clock cycle synchronization (ensure <math>T_o &gt; T_{dx}</math>).</li> </ul> Note: To: Time of setpoint acceptance Tdx: Data exchange time
<b>A1932: Drive Bus clock cycle synchronization missing for DSC</b>	There is no clock synchronization or clock synchronous sign of life and DSC is selected.  Note: DSC: Dynamic Servo Control	Set clock synchronization across the bus configuration and transfer clock synchronous sign-of-life.
<b>A5000: Drive heat sink over-temperature</b>	The alarm threshold for overtemperature at the inverter heat sink has been reached.  If the temperature of the heat sink increases by an additional 5 K, then fault F30004 is initiated.	Check the following: <ul style="list-style-type: none"> <li>Is the surrounding temperature within the defined limit values?</li> <li>Have the load conditions and the load duty cycle been appropriately dimensioned?</li> <li>Has the cooling failed?</li> </ul>
<b>A6310: Supply voltage (p29006) incorrectly parameterized</b>	For AC/AC drive units, the measured DC voltage lies outside the tolerance range after precharging has been completed.  The following applies for the tolerance range: $1.16 \times p29006 < r0026 < 1.6 \times p29006$  Note: The fault can only be acknowledged when the drive is switched off.	<ul style="list-style-type: none"> <li>Check the parameterized supply voltage and if required change it (p29006).</li> <li>Check the line supply voltage.</li> </ul> See also: p29006 (Line supply voltage)
<b>A7012: Motor temperature model 1/3 overtemperature</b>	The motor temperature model 1/3 identified that the alarm threshold was exceeded.	<ul style="list-style-type: none"> <li>Check the motor load and reduce it if required.</li> <li>Check the motor surrounding temperature.</li> </ul>
<b>A7092: Drive: Moment of inertia estimator still not ready</b>	The moment of the inertia estimator has still not determined any valid values.  The acceleration cannot be calculated.  The moment of inertia estimator has stabilized, if the ratio of machine load moment of inertia (p29022) have been determined.	Traverse the axis until the moment of inertia estimator has stabilized.  The alarm is automatically withdrawn after the moment of inertia estimator has stabilized.
<b>A7440: IPos: Jerk time is limited</b>	The calculation of the jerk time $T_r = \max(p2572, p2573)/p2574$ resulted in an excessively high value so that the jerk time is internally limited to 1000 ms.  Note: The alarm is also output if jerk limiting is not active.	<ul style="list-style-type: none"> <li>Increase the jerk limiting (p2574).</li> <li>Reduce maximum acceleration or maximum deceleration (p2572, p2573).</li> </ul> See also: p2572 (IPos maximum acceleration), p2573 (IPos maximum deceleration), p2574 (IPos jerk limiting)

Alarm	Cause	Remedy
<b>A7441: LR: Save the position offset of the absolute encoder adjustment</b>	The status of the absolute encoder adjustment has changed. In order to permanently save the determined position offset (p2525) it must be saved.	Not necessary. This alarm automatically disappears after the offset has been saved. See also: p2525 (LR encoder adjustment offset)
<b>A7454: LR: Position value preprocessing does not have a valid encoder</b>	The parameter configuration of encoder is incorrect.	Default the drive and re-configure the parameters.
<b>A7455: EPOS: Maximum velocity limited</b>	The maximum velocity (p2571) is too high to correctly calculate the modulo correction. Within the sampling time for positioning, with the maximum velocity, a maximum of the half modulo length must be moved through. p2571 was limited to this value.	Reduce the maximum velocity (p2571).
<b>A7456: EPOS: Setpoint velocity limited</b>	The actual setpoint velocity is greater than the parameterized maximum velocity and is therefore limited.	Decrease the actual setpoint velocity.
<b>A7461: EPOS: Reference point not set</b>	When starting a traversing block/direct setpoint input, a reference point is not set.	Reference the system (search for reference, flying referencing, set reference point).
<b>A7469: EPOS: Traversing block &lt; target position &lt; software limit switch minus</b>	In the traversing block the specified absolute target position lies outside the range limited by the software limit switch minus.	<ul style="list-style-type: none"> <li>• Correct the traversing block.</li> <li>• Change software limit switch minus (p2580).</li> </ul>
<b>A7470: EPOS: Traversing block &gt; target position &gt; software limit switch plus</b>	In the traversing block the specified absolute target position lies outside the range limited by the software limit switch plus.	<ul style="list-style-type: none"> <li>• Correct the traversing block.</li> <li>• Change software limit switch plus (p2581).</li> </ul>
<b>A7471: EPOS: Traversing block target position outside the modulo range</b>	In the traversing block the target position lies outside the modulo range.	<ul style="list-style-type: none"> <li>• In the traversing block, correct the target position.</li> <li>• Change the modulo range (p29246).</li> </ul>
<b>A7472: EPOS: Traversing block ABS_POS/ABS_NEG not possible</b>	In the traversing block the positioning mode ABS_POS or ABS_NEG were parameterized with the modulo correction not activated.	Correct the traversing block.
<b>A7473: EPOS: Beginning of traversing range reached</b>	When traversing, the axis has moved to the traversing range limit.	Move away in the positive direction.
<b>A7474: EPOS: End of traversing range reached</b>	When traversing, the axis has moved to the traversing range limit.	Move away in the negative direction.
<b>A7477: EPOS: Target position &lt; software limit switch minus</b>	In the actual traversing operation, the target position is less than the software limit switch minus.	<ul style="list-style-type: none"> <li>• Correct the target position.</li> <li>• Change software limit switch minus (CI: p2580).</li> </ul>
<b>A7478: EPOS: Target position &gt; software limit switch plus</b>	In the actual traversing operation, the target position is greater than the software limit switch plus.	<ul style="list-style-type: none"> <li>• Correct the target position.</li> <li>• Change software limit switch plus (CI: p2581).</li> </ul>
<b>A7479: EPOS: Software limit switch minus reached</b>	The axis is at the position of the software limit switch minus. An active traversing block was interrupted.	<ul style="list-style-type: none"> <li>• Correct the target position.</li> <li>• Change software limit switch minus (CI: p2580).</li> </ul>



Alarm	Cause	Remedy
<b>A7480: EPOS: Software limit switch plus reached</b>	The axis is at the position of the software limit switch plus. An active traversing block was interrupted.	<ul style="list-style-type: none"> <li>Correct the target position.</li> <li>Change software limit switch plus (CI: p2581).</li> </ul>
<b>A7496: SON enable missing</b>	<ul style="list-style-type: none"> <li>In the IPos control mode or a compound control mode with IPos, no servo on command is sent to the drive via Modbus when p29008 = 1.</li> <li>In the IPos control mode, rising edge is triggered for the P-TRG signal when the drive is in servo off status.</li> <li>In the PTI control mode, any faults which is caused by implementing the "Enable trial run" operation with the V-ASSISTANT lead to A7496.</li> </ul>	<ul style="list-style-type: none"> <li>Send servo on command to the drive via Modbus</li> <li>Set the drive to servo on status firstly and trigger a rising edge for the P-TRG signal.</li> <li>Acknowledge the faults firstly and implement "Enable trial run" again.</li> </ul>
<b>A7576: Encoderless operation due to a fault active</b>	Encoderless operation is active due to a fault.	<ul style="list-style-type: none"> <li>Remove the cause of a possible encoder fault.</li> <li>Carry out a POWER ON (power off/on) for all components.</li> </ul>
<b>A7582: Position actual value preprocessing error</b>	An error has occurred during the position actual value preprocessing.	Check the encoder for the position actual value preprocessing. Refer to F52931.
<b>A7585: P-TRG or CLR active</b>	In the PTI mode or a compound mode with PTI, the P-TRG or CLR function is activated.	In the PTI mode, deactivate the P-TRG or CLR function; in the compound mode with PTI, do not switch to other modes.
<b>A7588: Encoder 2: Position value preprocessing does not have a valid encoder</b>	The parameter configuration of PTI counter is incorrect.	Default the drive and re-configure the parameters.
<b>A7805: Power unit overload I<sup>2</sup>t</b>	Alarm threshold for I <sup>2</sup> t overload of the power unit exceeded.	<ul style="list-style-type: none"> <li>Reduce the continuous load.</li> <li>Adapt the load duty cycle.</li> <li>Check the assignment of the rated currents of the motor and motor module.</li> </ul>
<b>A7965: Save required</b>	The angular commutation offset was re-defined and has still not been saved. In order to permanently accept the new value, it must be saved in a non-volatile fashion.	This alarm automatically disappears after the data has been saved.
<b>A7971: Angular commutation offset determination activated</b>	The automatic determination of the angular commutation offset (encoder adjustment) is activated. The automatic determination is carried out at the next power-on command.	The alarm automatically disappears after determination.
<b>A7991: Motor data identification activated</b>	The motor data identification routine is activated. The motor data identification routine is carried out at the next power-on command.	The alarm automatically disappears after the motor data identification routine has been successfully completed. If a POWER ON or a warm restart is performed with motor data identification selected, the motor data identification request will be lost. If motor data identification is required, it will need to be selected again manually following ramp-up.

11.2 List of faults and alarms

Alarm	Cause	Remedy
<b>A30016: Load supply switched off</b>	The DC link voltage is too low.	<ul style="list-style-type: none"> <li>• Switch on the load supply.</li> <li>• Check the line supply if necessary.</li> </ul>
<b>A30031: Hardware current limiting in phase U</b>	<p>Hardware current limit for phase U responded. The pulsing in this phase is inhibited for one pulse period.</p> <ul style="list-style-type: none"> <li>• Closed-loop control is incorrectly parameterized.</li> <li>• Fault in the motor or in the power cables.</li> <li>• The power cables exceed the maximum permissible length.</li> <li>• Motor load too high.</li> <li>• Power unit defective.</li> </ul> <p>Note: Alarm A30031 is always output if, for a power unit, the hardware current limiting of phase U, V or W responds.</p>	<p>Check the motor data. As an alternative, run a motor data identification.</p> <ul style="list-style-type: none"> <li>• Check the motor circuit configuration (star-delta)</li> <li>• Check the motor load.</li> <li>• Check the power cable connections.</li> <li>• Check the power cables for short-circuit or ground fault.</li> <li>• Check the length of the power cables.</li> </ul>
<b>A31411: Encoder 1: Absolute encoder signals internal alarms</b>	The absolute encoder fault word includes alarm bits that have been set.	<ul style="list-style-type: none"> <li>• Check the encoder cable connection and make sure the cables are routed in compliance with EMC.</li> <li>• Check the motor temperature.</li> <li>• Replace the motor/encoder.</li> </ul>
<b>A31412: Error bit set in the serial protocol</b>	The encoder sends a set error bit via the serial protocol.	<ul style="list-style-type: none"> <li>• Carry out a POWER ON (power off/on) for all components.</li> <li>• Check that the cables are routed in compliance with EMC.</li> <li>• Check the plug connections.</li> <li>• Replace the encoder.</li> </ul>
<b>A52900: Failure during data copying</b>	<ul style="list-style-type: none"> <li>• Copying is halted.</li> <li>• The micro SD card/SD card was plugged out.</li> <li>• The drive is not in the stop state.</li> </ul>	<ul style="list-style-type: none"> <li>• Re-plug in the micro SD card/SD card.</li> <li>• Make sure the drive is in the stop state.</li> </ul>
<b>A52901: Braking resistor reaches alarm threshold</b>	The heat capacity reaches the threshold (p29005) of the braking resistor capacity.	<ul style="list-style-type: none"> <li>• Change the external braking resistor.</li> <li>• Increase deceleration time.</li> </ul>
<b>A52902: Quick stop (EMGS) missing</b>	Implement servo on when the digital input (EMGS) is switched off.	Switch on the digital input (EMGS) and then implement servo on.
<b>A52932: PTO max limit</b>	<p>For incremental encoder, when PTO frequency exceeds 280K, drive will output A52932 to remind that exceed limitation.</p> <p>For absolute encoder, when PTO frequency exceeds 120K, drive will output A52932 to remind that exceed limitation.</p>	Change PTO ratio.

## Appendix

### A.1 Assembly of cable terminals on the drive side

#### Power terminal assembly

SINAMICS V90		Procedure	Illustration
200 V variant	FSA FSB FSC FSD	Terminal assembly procedure: 1. Remove the outer sheath of the cable. 2. Remove the insulation from the wire. 3. Insert the stripped end into the cable end sleeve. 4. Crimp the cable end sleeve using a crimp tool for end sleeves.	<p>1. Cable length: <math>120 \pm 5</math> mm, wire length: <math>10 \pm 2</math> mm.</p> <p>2. <math>a &gt; 11</math> mm, <math>b = 10</math> mm.</p> <p>3. <math>c &gt; 1</math> mm.</p> <p>4. <math>d = 8</math> mm.</p>
400 V variant	FSB FSC	Terminal assembly procedure: 1. Remove the outer sheath of the cable. 2. Remove the insulation from the wire. 3. Insert the stripped end into the spade terminal. 4. Crimp the spade terminal using a crimp tool for cable lugs. (Note: Coat any exposed wires with tin.)	<p>1. Cable length: <math>200 \pm 5</math> mm, wire length: <math>10 \pm 2</math> mm.</p> <p>2. <math>a = 6</math> mm, <math>b = 10.7</math> mm.</p> <p>3. Spade terminal being inserted into the wire.</p> <p>4. Completed assembly.</p>

### Encoder terminal assembly

The terminal assembly procedures for absolute and incremental encoders are the same.

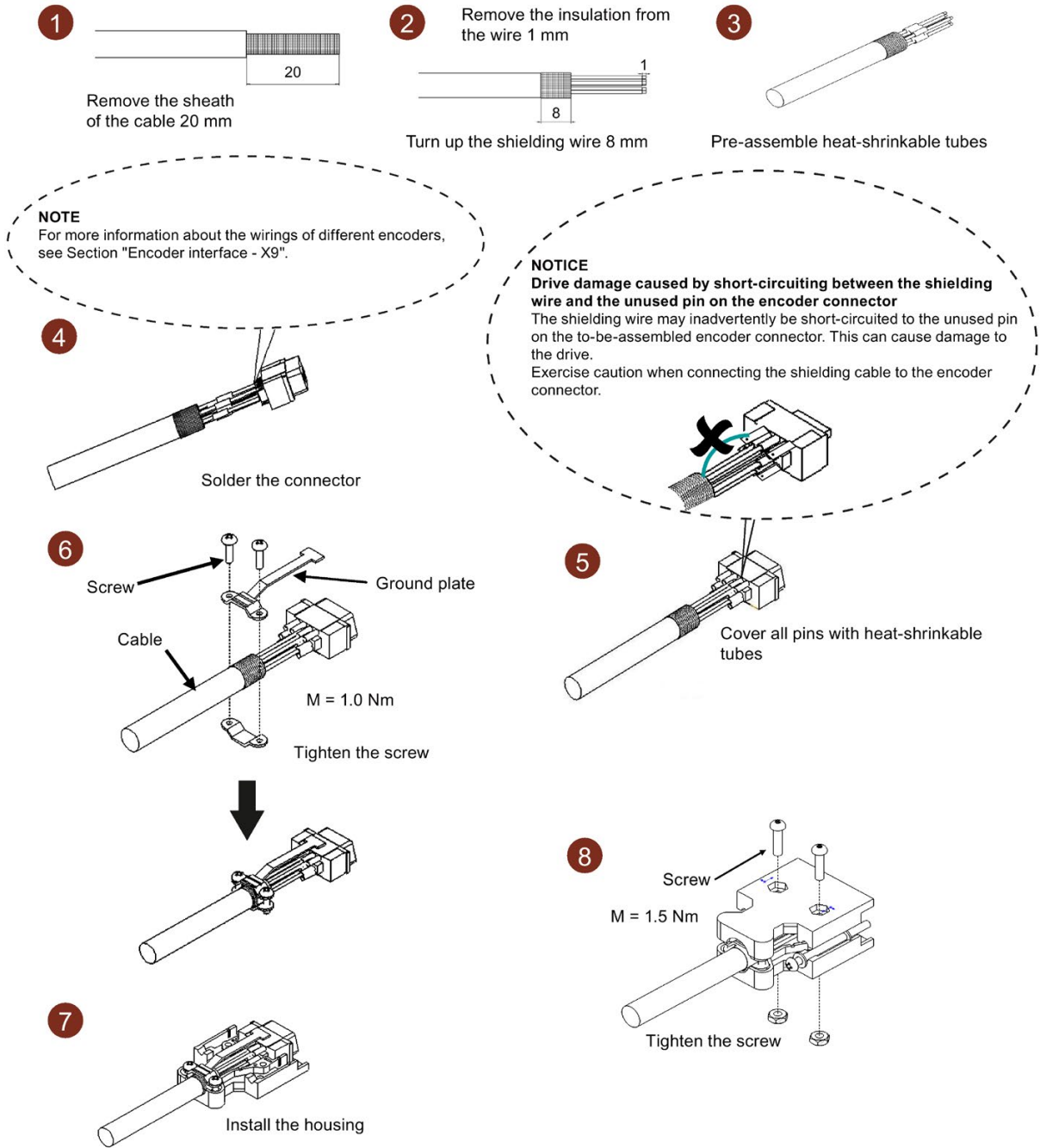

### Brake terminal assembly

The assembly of a brake terminal follows the procedure as described in the figure above for a power terminal.

### Setpoint connector assembly

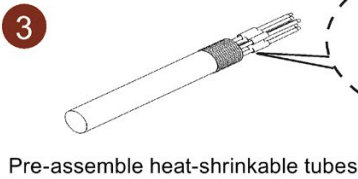
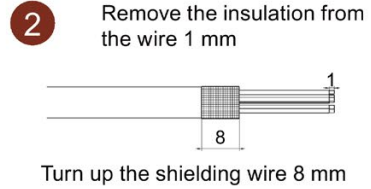
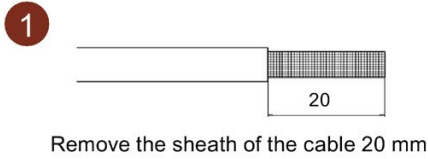

**NOTICE**  
 You are recommended to assemble the heat-shrinkable tubes to all the used pins. The following pins of the setpoint cable connector must be assembled with heat-shrinkable tubes no matter whether they are used or not. They are pin 15, pin 16, pin 40, pin 41, pin 42, and pin 43.

**NOTICE**  
**Drive damage caused by short-circuiting between the shielding wire and the above pins on the setpoint cable connector**  
 The shielding wire may inadvertently be short-circuited to the above pins on the to-be-assembled setpoint cable connector. This can cause damage to the drive.  
 Exercise caution when connecting the shielding cable to the setpoint cable connector.

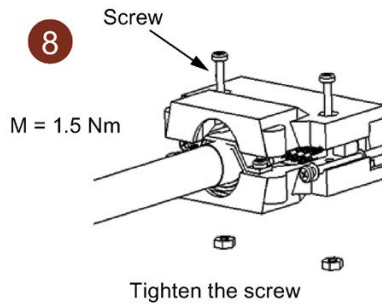
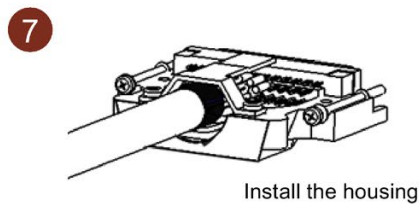
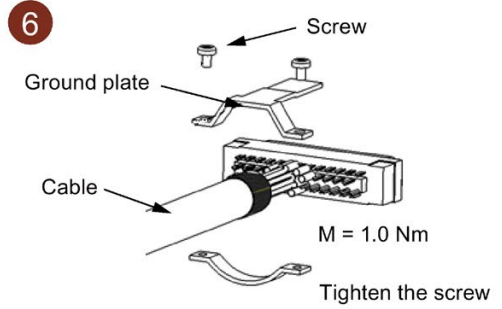
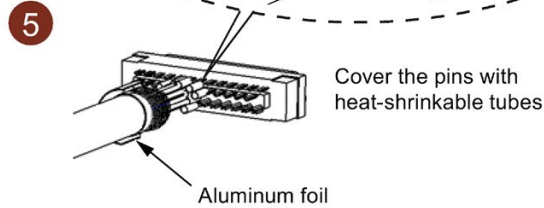
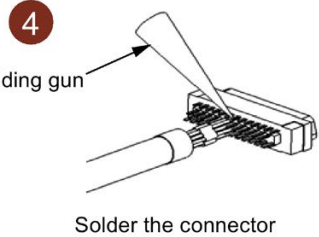

## A.2 Assembly of cable connectors on the motor side

### Power connector assembly

Power cable used for low inertia motors with a shaft height of 20 mm to 40 mm

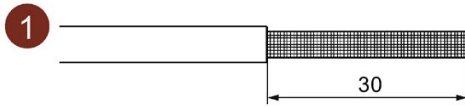

Remove the sheath of the cable 30 mm

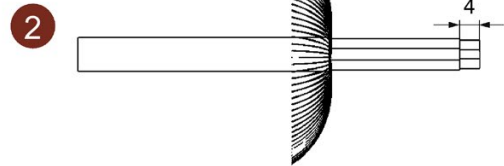

Remove the insulation from the wire 4 mm

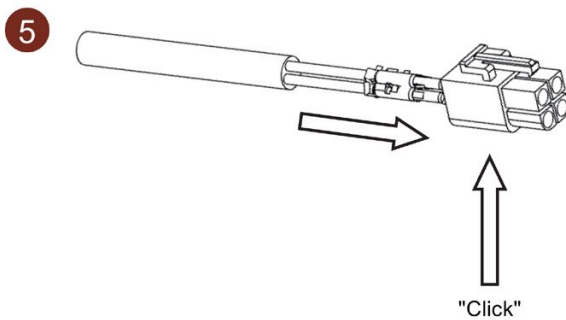
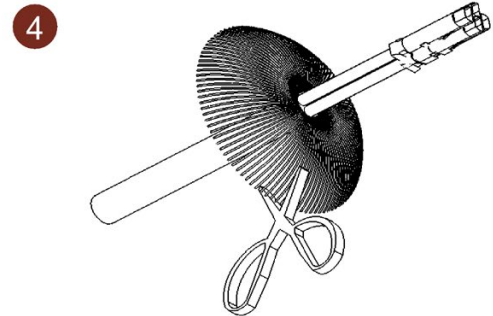
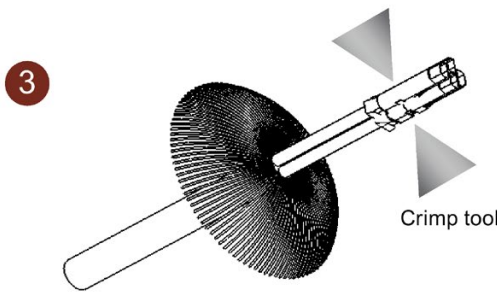

#### Note

#### Brake connector assembly

The assembly of the brake connector used for low inertia motors with a shaft height of 20 mm to 40 mm follows the procedure as described in the figure above for a power connector.

Power cable used for motors with straight connectors (low inertia motors with a shaft height of 50 mm and high inertia motors)

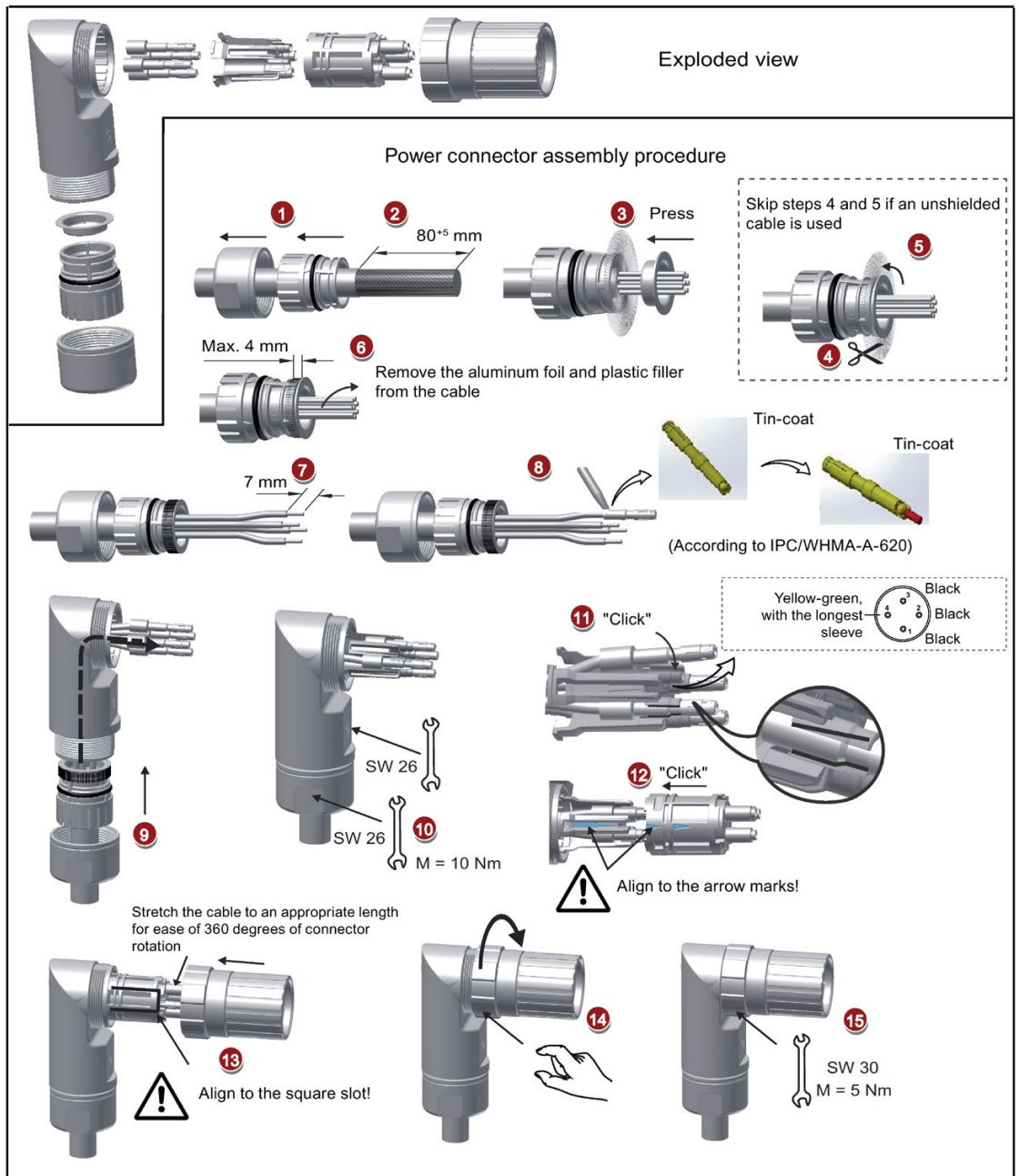



Power cable used for motors with angular connectors (low inertia motors with a shaft height of 50 mm and high inertia motors)

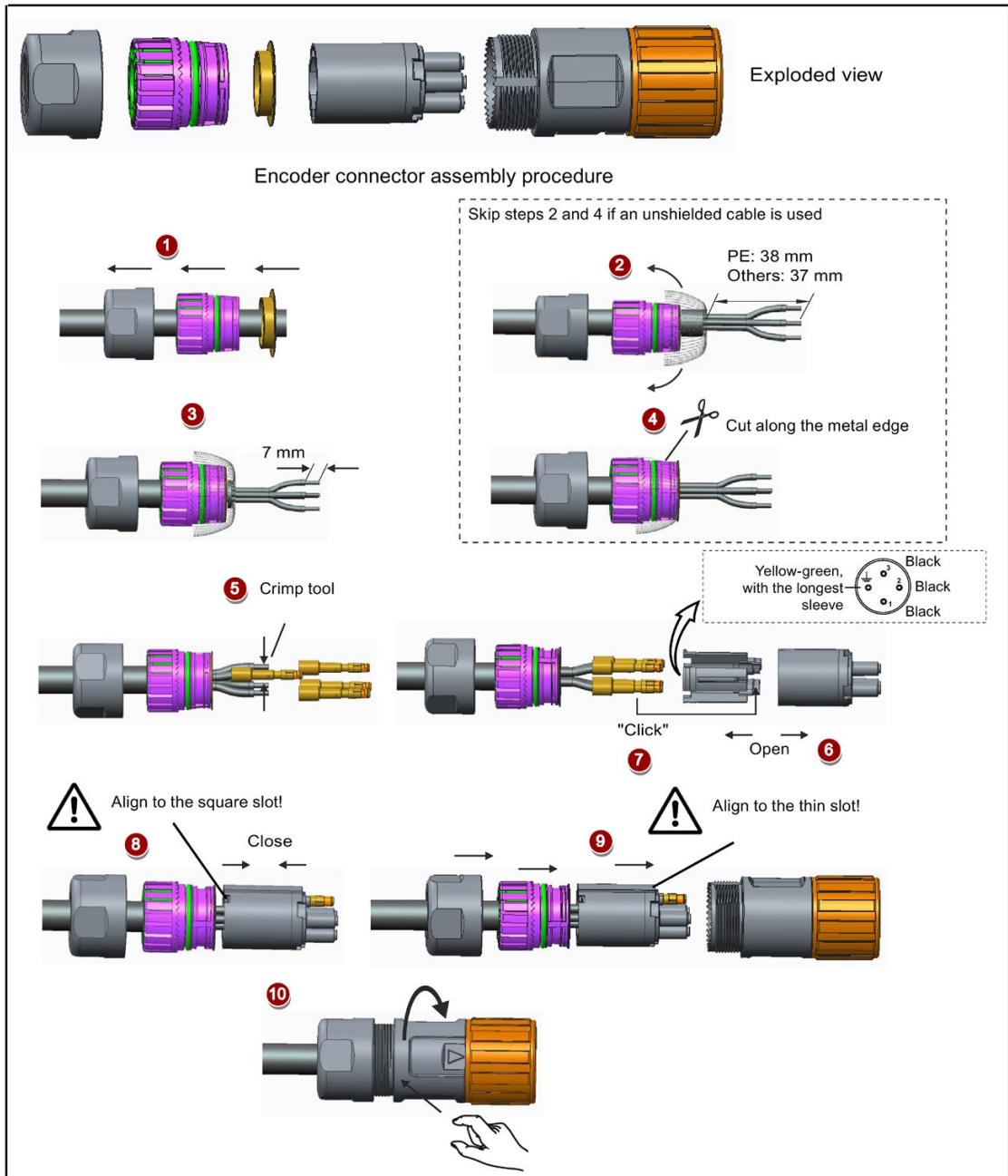



### Encoder connector assembly

Incremental encoder cable used for low inertia motors with a shaft height of 20 mm to 40 mm

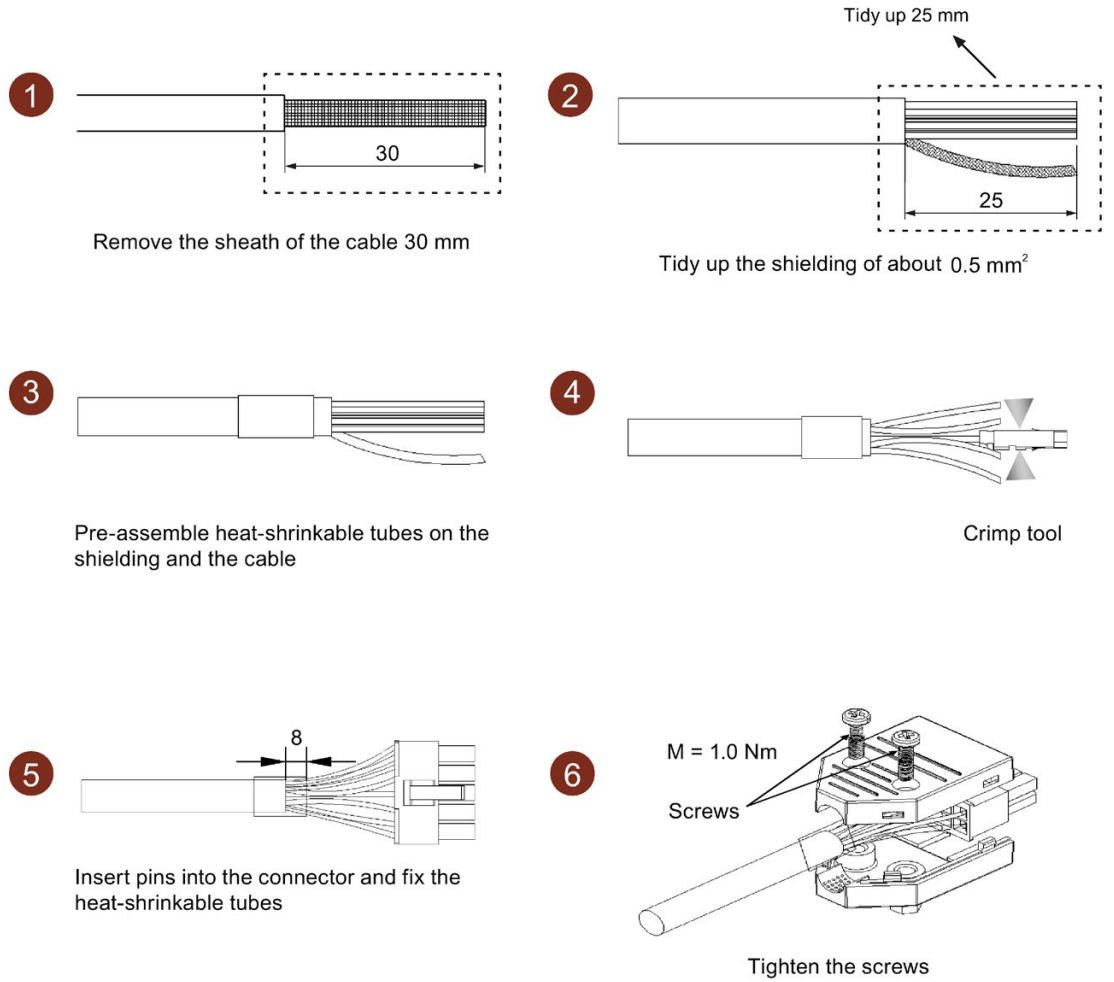

Absolute encoder cable used for low inertia motors with a shaft height of 20 mm to 40 mm

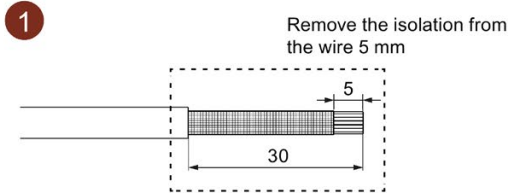

Remove the sheath of the cable 30 mm

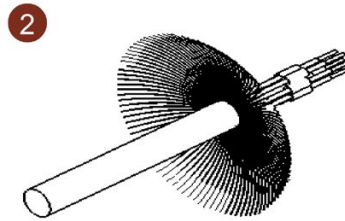

Pre-assembly the heat-shrink tubes

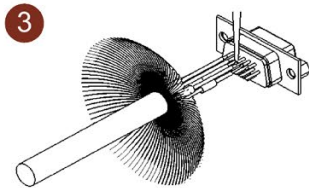

Solder the connector

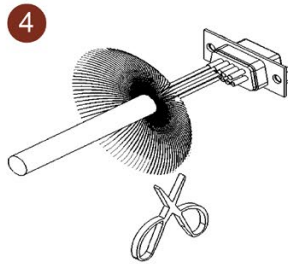

Shield retaining 10 mm

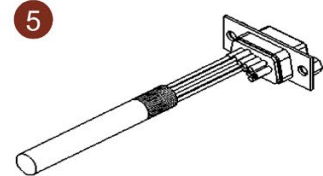

Turn up shielding 10 mm.  
Cover all pins with heat-shrinkable tubes

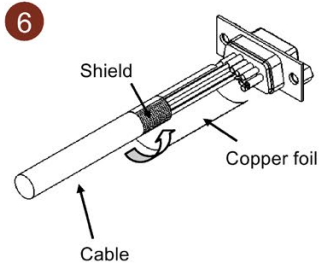

Twine the copper foil on the core wire

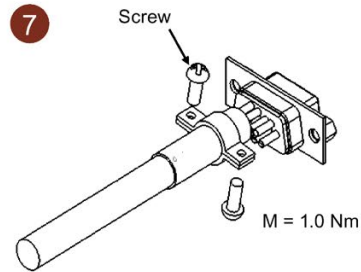

Tighten the screw

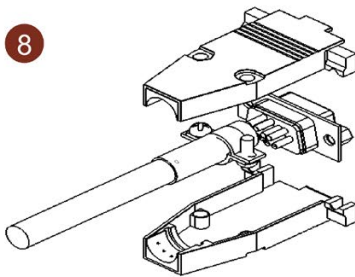

Install housing

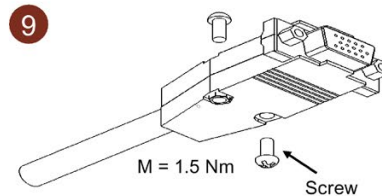

Tighten the screw

**Encoder cable used for motors with straight connectors (low inertia motors with a shaft height of 50 mm and high inertia motors)**

The connector assembly procedures for absolute and incremental encoders are the same.

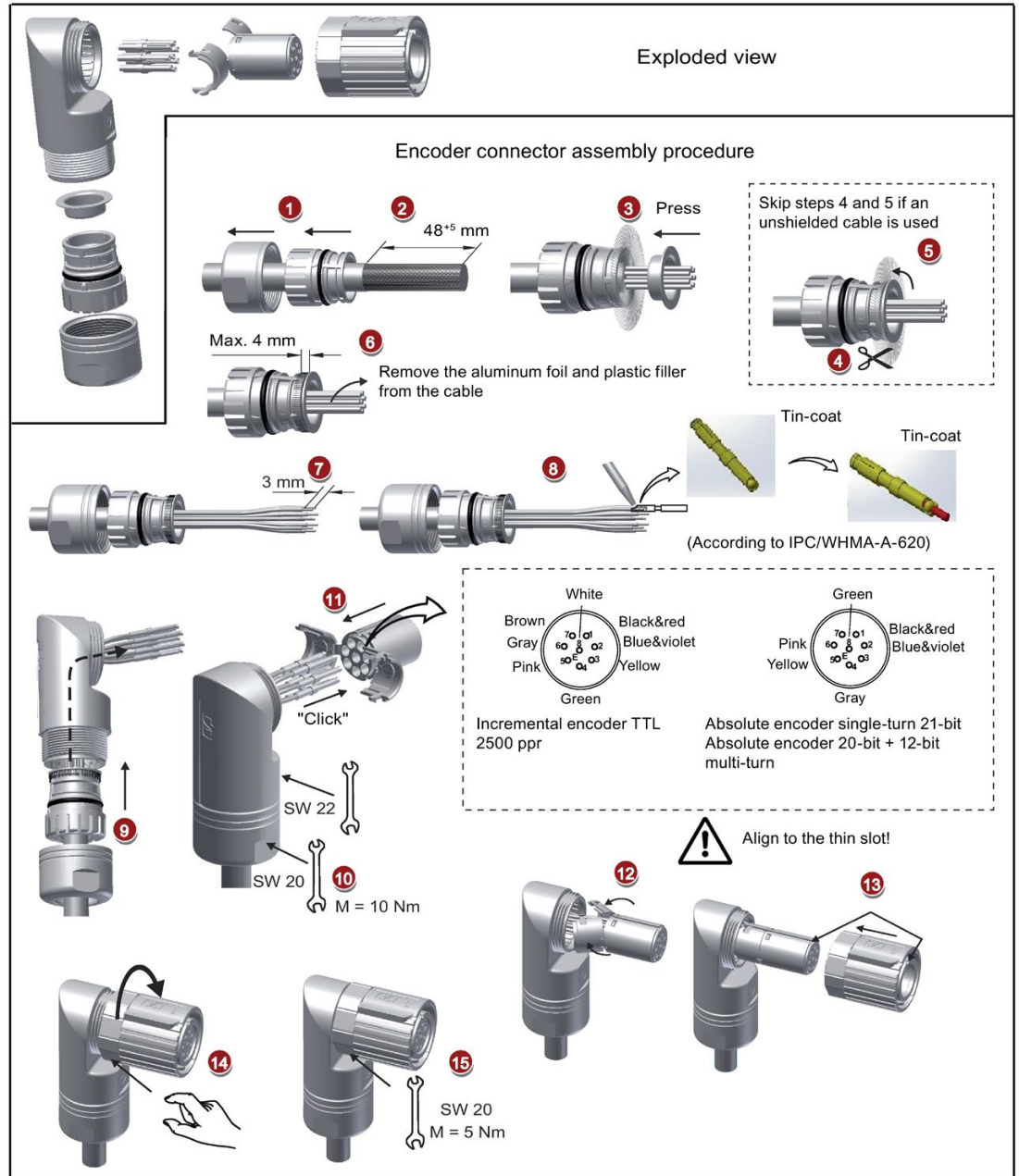

**Note**

**Brake connector assembly for motors with straight connectors**

The assembly of the brake connector used for motors with straight connectors (low inertia motors with a shaft height of 50 mm and high inertia motors) follows the procedure as described in the figure above for an encoder connector.

**Incremental encoder cable used for motors with angular connectors (low inertia motors with a shaft height of 50 mm and high inertia motors)**

For a low inertia motor with a shaft height of 50 mm, the connector assembly procedures for absolute and incremental encoders are the same.

For a high inertia motors with angular connectors, you can assemble the absolute encoder connector with the procedures shown in the figure above.

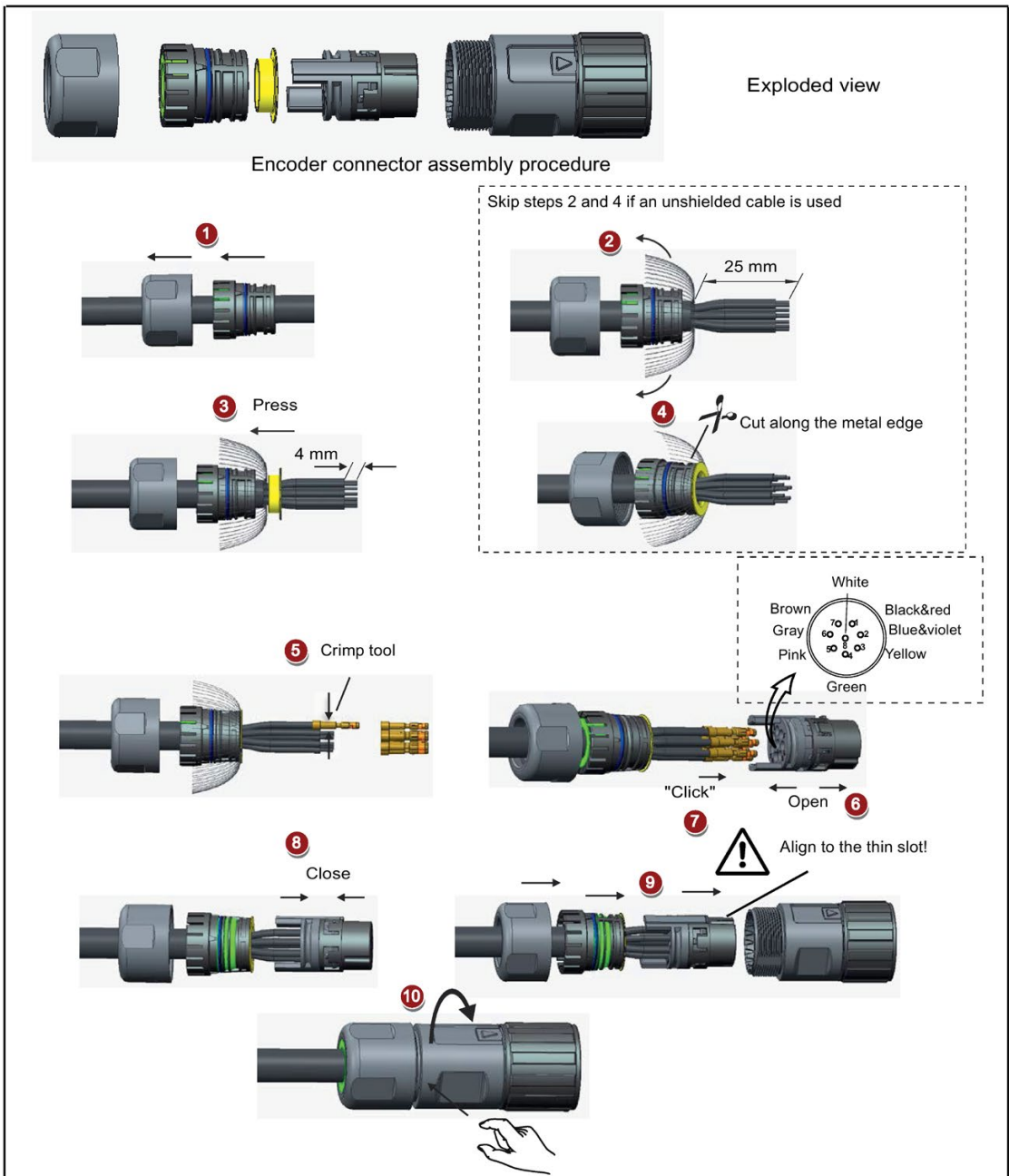

**Note**

**Brake connector assembly for motors with angular connectors**

The assembly of the brake connector used for motors with angular connectors (low inertia motor with a shaft height of 50 mm and high inertia motors) follows the procedure as described in the figure above for an incremental encoder connector.

## A.3 Motor selection

### A.3.1 Selection procedure

1. Determine the mechanism type as well as the detailed data of the related mechanical parts, such as ball screw lead, diameter, lead, and gear diameter. Three mechanism types are shown below:

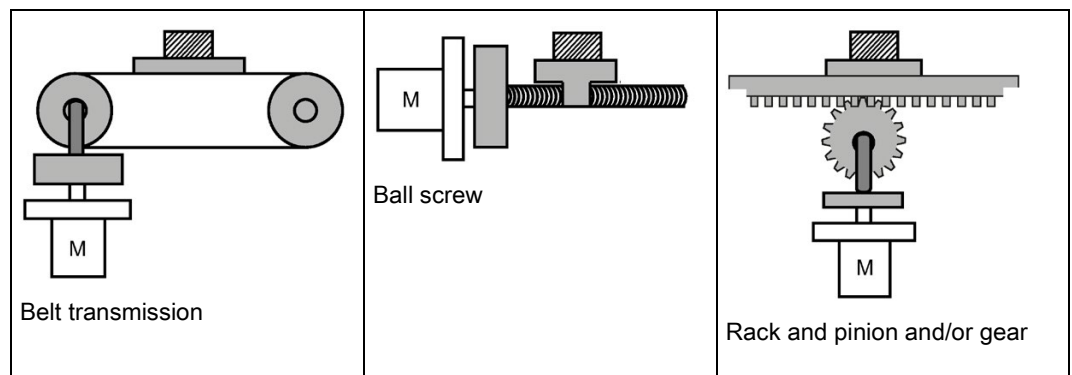

2. Determine the operation pattern including such parameters as acceleration time ( $t_a$ ), constant motion time ( $t_u$ ), deceleration time ( $t_d$ ), stopping time ( $t_s$ ), cycle time ( $t_c$ ), and travel distance ( $L$ ).

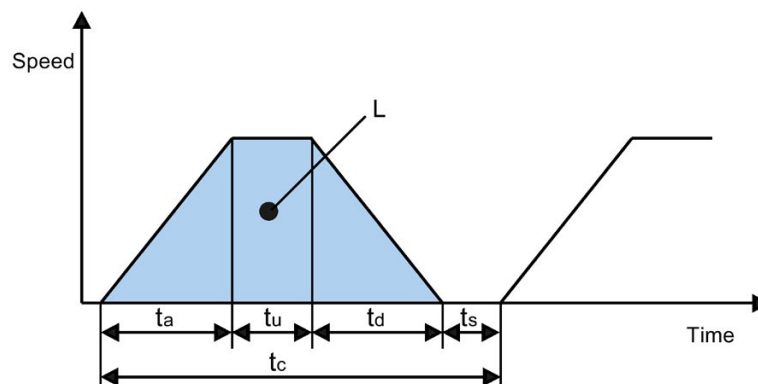

3. Calculate load inertia and inertia ratio.  
The inertia ratio can be obtained by dividing the load inertia by the rotor inertia of the selected motor. The unit of inertia is  $\times 10^{-4} \text{ kg}\cdot\text{m}^2$ .

4. Calculate the speed.  
Calculate the speed according to the travel distance, acceleration time, deceleration time, and constant motion time.
5. Calculate the torque.  
Calculate the torque according to the load inertia, acceleration time, deceleration time, and constant motion time.
6. Select the motor.  
Select the motor that matches the data in step 3 to step 5.

## A.3.2 Parameter description

### Torque

- Summit torque: It refers to the maximum torque required by a motor in operation, which is generally less than 80% of the motor's maximum torque. When the torque is a negative value, regenerative resistors may be needed.
- Moving torque and hold torque in standstill: It refers to the torque required by a motor in long-term operation, which is generally less than 80% of the motor's rated torque. When the torque is a negative value, regenerative resistors may be needed.  
Torque calculation methods of two major mechanism types:

$$T_m = \frac{P_b}{2\pi\eta} (\mu g W + F)$$

W: Mass [kg]

P<sub>b</sub>: Ball screw lead [m]

F: External force [N]

η: Mechanical efficiency

μ: Friction coefficient

g: Gravitational acceleration 9.8 [m/s<sup>2</sup>]

$$T_m = \frac{P_d}{2\eta} (\mu g W + F)$$

W: Mass [kg]

P<sub>d</sub>: Belt transmission lead [m]

F: External force [N]

η: Mechanical efficiency

μ: Friction coefficient

g: Gravitational acceleration 9.8 [m/s<sup>2</sup>]

- Effective torque: It refers to the continuous effective load torque converted into the equivalent value on the servo motor shaft, which is generally less than 80% of the motor's rated torque.

$$T_{rms} = \sqrt{\frac{T_a^2 \times t_a + T_m^2 \times t_u + T_d^2 \times t_d}{t_c}}$$

T<sub>a</sub>: Acceleration torque [N·m]

t<sub>a</sub>: Acceleration time [s]

t<sub>c</sub>: Cycle time [s]

T<sub>m</sub>: Moving torque [N·m]

t<sub>u</sub>: Constant motion time [s]

T<sub>d</sub>: Deceleration torque [N·m]

t<sub>d</sub>: Deceleration time [s]

## Speed

Maximum speed: It refers to the motor's maximum speed in operation, which is generally lower than the rated speed. When a motor operating at the maximum speed, pay attention to its torque and temperature rise.

## Inertia and inertia ratio

Inertia refers to the force required to keep a certain physical state. Inertia ratio indicates dynamic response performance of motors. The smaller the inertia ratio is the better response performance a motor has.

## Typical load inertia equations

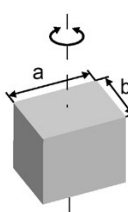
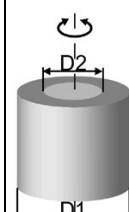
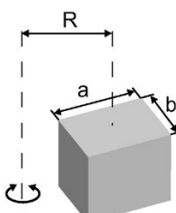
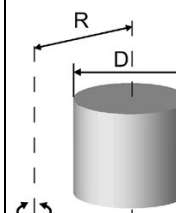
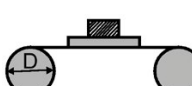
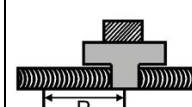
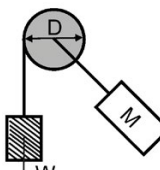
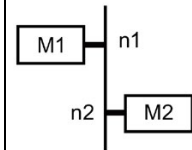
Mechanism	Equation	Mechanism	Equation
 <p>Axis of rotation on center</p>	$J = \frac{W}{12} (a^2 + b^2)$ <p>W: Mass (kg) a: Length (m) b: Width (m)</p>	 <p>Axis of rotation on center</p>	$J = \frac{W}{8} (D_1^2 + D_2^2)$ <p>W: Mass (kg) D<sub>1</sub>: External diameter (m) D<sub>2</sub>: Internal diameter (m)</p>
 <p>Axis of rotation off center</p>	$J = W \cdot \left( \frac{a^2 + b^2}{3} + R^2 \right)$ <p>W: Mass (kg) a: Length (m) b: Width (m) R: Rotational diameter (m)</p>	 <p>Axis of rotation off center</p>	$J = \frac{W}{8} (D^2 + 8R^2)$ <p>W: Mass (kg) D: Workpiece diameter (m) R: Rotational diameter (m)</p>
 <p>Conveyor</p>	$J = \frac{W \cdot D^2}{4}$ <p>W: Mass (kg) D: Pulley wheel diameter (m)</p>	 <p>Ball screw</p>	$J = \frac{W \cdot P^2}{4\pi^2} + J_b$ <p>W: Mass (kg) P: Lead (m) J<sub>b</sub>: Ball screw inertia (kg·m<sup>2</sup>)</p>
 <p>Object hung with pulley</p>	$J = W \cdot \left( \frac{D}{2} \right)^2 + J_p$ <p>W: Mass (kg) D: Pulley wheel diameter (m) J<sub>p</sub>: Pulley inertia (kg·m<sup>2</sup>)</p>	 <p>Reducer</p>	$J = J_1 \cdot \frac{n_1^2}{n_2^2} \cdot J_2$ <p>W: Mass (kg) n<sub>1</sub>/n<sub>2</sub>: Speed of each motor (rpm) J<sub>1</sub>/J<sub>2</sub>: Inertia of each motor (kg·m<sup>2</sup>)</p>

### A.3.3 Selection examples

This section uses a ball screw mechanism as an example to illustrate the motor selection procedure.

#### Exemplary data

The following table lists the data related to the ball screw mechanism and operation pattern.

Mechanism		Operation pattern	
Workpiece weight (W)	40 kg	Acceleration time ( $t_a$ )	0.15 s
Ball screw length ( $B_l$ )	2 m	Constant motion time ( $t_u$ )	0.7 s
Ball screw diameter ( $B_d$ )	0.04 m	Deceleration time ( $t_d$ )	0.15 s
Ball screw pitch ( $B_p$ )	0.04 m	Cycle time ( $t_c$ )	2 s
Mechanical efficiency ( $B_\eta$ )	0.9	Travel distance (L)	0.5 m
Coupler inertia ( $J_c$ )	$20 \times 10^{-6} \text{ kg}\cdot\text{m}^2$ (refer to the supplier's product catalog)	-	

#### 1. Ball screw weight

$$B_w = \rho \times \pi \times (B_d/2)^2 \times B_l = 19.85 \text{ kg}$$

#### 2. Load inertia

$$J_l = J_c + J_b = J_c + 1/8 \times B_w \times B_d^2 + W \times B_p^2 / 4\pi^2 = 5.61 \times 10^{-3} \text{ kg}\cdot\text{m}^2$$

#### 3. Preselection

If a 1000 W motor is selected,  $J_m$  (motor inertia) =  $1.57 \times 10^{-3} \text{ kg}\cdot\text{m}^2$

Therefore,  $J_l / J_m$  (inertia ratio) =  $3.57 < 5$  times

#### 4. Maximum rotational speed

$$V_{\max} \text{ (maximum travelling speed)} = 2L / (t_a + 2t_u + t_d) = 5.89 \text{ m/s}$$

$$N_{\max} \text{ (maximum rotational speed)} = 60 \times V_{\max} / B_p = 882 \text{ rpm} < 2000 \text{ rpm (rated speed)}$$

#### 5. Effective torque

$$T_m \text{ (moving torque)} = (\mu gW + F) \times B_p / 2\pi B_\eta = 0.069 \text{ Nm}$$

$$T_a \text{ (acceleration torque)} = [(J_l + J_m) \times 2\pi N / T_a] + T_m = 4.49 \text{ Nm}$$

$$T_d \text{ (deceleration torque)} = [(J_l + J_m) \times 2\pi N / T_d] - T_m = 4.35 \text{ Nm}$$

$$\text{Therefore, } T_{\text{rms}} \text{ (effective torque)} = \sqrt{(T_a^2 \times t_a + T_m^2 \times t_b + T_d^2 \times t_d)} / t_c = 1.71 \text{ Nm} < 4.78 \text{ Nm (rated torque)}$$

#### 6. Final selection

According to the above calculated speed, torque, and inertia ratio, you are recommended to select 1000 W motors, i.e. 1FL6062.



## A.4 Replacing fans

Proceed as illustrated below to remove the fan from the drive. To re-assemble the fan, proceed in reverse order. When re-assembling the fan, make sure that the arrow symbol ("A" in the illustration) on the fan points to the drive rather than the fan housing.

### Replacing the fan (example)

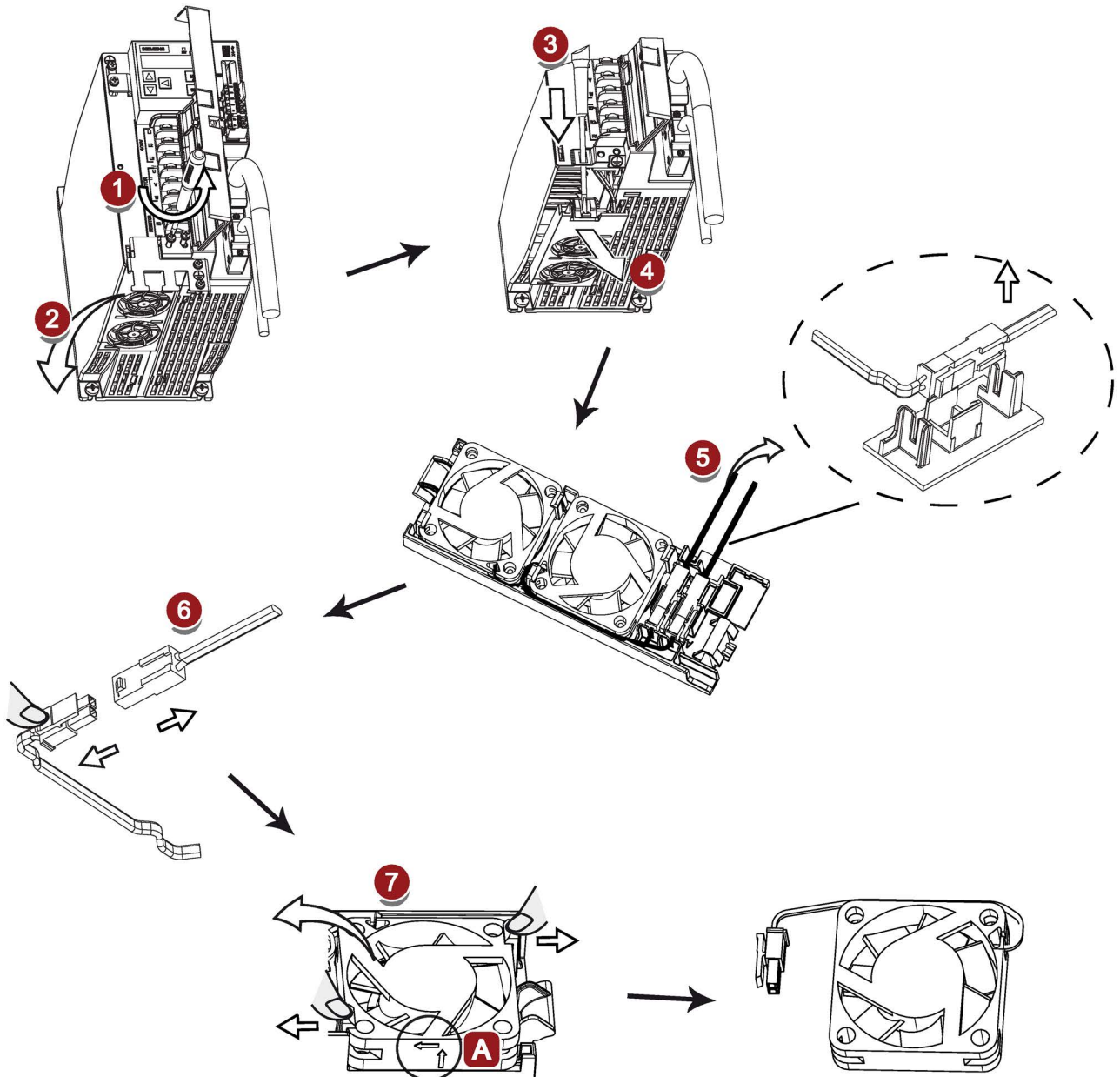

# Index

- A**
- Accessories
  - Braking resistor, 45
  - External 24 VDC power supply, 43
  - Filter, 46
  - Fuse/Type-E combination motor controller, 44
  - MOTION-CONNECT 300 cable and connector, 41
  - Replacement fans, 52
  - SD card/Micro SD card, 52
  - Setpoint cable, 42
- Adjust AI offset, 179
- Aims, 264
- analog inputs, 117
- Analog inputs
  - Command voltage, 117
- analog outputs, 117
- Analog outputs
  - Parameterization, 118
  - Wiring, 118
- ANSI B11, 275
  
- B**
- Backlash compensation, 210
- BOP operations
  - Button functions, 166
- BOP operations for faults and alarms, 352
  - Acknowledging faults, 353
  - Exiting from alarm display, 352
  - Exiting from fault display, 352
  - Viewing alarms, 352
  - Viewing faults, 352
- BOP overview, 162
  
- C**
- Certification, 277
- Change a parameter value, 170
  - Parameter setting with shift function, 171
- Commissioning
  - Initial commissioning, 153
- Connecting 24 V power supply/STO, 139
- Connecting an external braking resistor, 144
- Connecting the RS485 interface, 150
  
- Connecting the SIMATIC S7-1200
  - For internal position control (IPos), 136
  - For pulse train input position control (PTI), 135
  - For speed control (S), 137
  - For torque control (T), 138
- Connecting the SIMATIC S7-200
  - For internal position control (IPos), 132
  - For pulse train input position control (PTI), 131
  - For speed control, 133
  - For torque control, 134
- Connecting the SIMATIC S7-200 SMART
  - For internal position control (IPos), 128
  - For pulse train input position control (PTI), 126
  - For speed control (S), 129
  - For torque control (T), 130
- Copy parameter set from a micro SD card/SD card to drive, 177
- Copy parameters from the servo drive to a micro SD card/SD card, 176
  
- D**
- Differences between faults and alarms, 351
- Digital inputs, 107
  - Direct signal map, 111
  - Wiring, 111
- Digital outputs, 112
  - Assigning warning signals to digital outputs, 114
- DIN EN ISO 13849-1, 268
- Direction of motor rotation, 188
- Drive rating plate, 23
  
- E**
- EN 61508, 270
- EN 62061, 269
- Equipment regulations, 276
  
- F**
- Function list, 52
- Functional safety, 265
  
- G**
- Gain switch, 301

Gain switching using actual speed, 304  
 Gain switching using an external digital input signal, 302  
 Gain switching using position deviation, 303  
 Gain switching using position setpoint frequency, 303  
 General information about faults and alarms, 350

## H

Harmonized European Standards, 266

## I

Internal position control mode (IPos)  
   Linear/modular axis, 210  
   Position setpoint, 207  
   Selecting a fixed position setpoint and starting positioning, 220  
   Selecting a positioning mode, 209  
   Setting mechanical system, 206  
   Software position limit, 220  
 Iterative process for achieving safety, 271

## J

Jog function, 174  
   Jog in speed, 174  
   Jog in torque, 174

## L

LED status indicators, 163

## M

Machine safety in Japan, 276  
 Machine safety in the USA, 273  
 Machinery directive, 265  
 Main circuit wirings  
   Connecting the motor power - U, V, W, 101  
 Motor holding brake, 145  
   Relevant parameters, 149  
 Motor rating plate, 28  
 Motor selection method, 383  
 Mounting the motor  
   Motor dimensions, 84  
   Mounting orientation, 81

## N

NFPA 79, 274  
 NRTL, 274

## O

Operating display, 168  
 OSHA, 273  
 Over-travel, 189  
 Overview of absolute position system, 261  
   Restrictions, 261  
 Overview of SINAMICS V90 BOP functions, 173

## P

Parameter value, 252  
 PI to P switching using torque setpoint, 307  
 PI/P switching, 305  
 PI/P switching using acceleration setpoint, 309  
 PI/P switching using an external digital input signal, 307  
 PI/P switching using pulse deviation, 310  
 PI/P switching using speed setpoint, 308  
 Preface  
   Documentation components, 3  
   Target group, 3  
   Technical support, 3  
 Probability of failure, 279  
 PTO  
   Wiring, 116  
 Pulse train encoder outputs, 116  
 Pulse train input position control mode (PTI)  
   Calculating electronic gear ratio, 195  
   Clearing droop pulses, 203  
   In position (INP), 194  
   P-TRG, 198  
   Selecting a setpoint pulse train input channel, 192  
   Selecting a setpoint pulse train input form, 193  
   Smoothing function, 194  
 Pulse train inputs  
   Wiring, 115

## R

Referencing  
   Referencing modes, 211  
 Residual risk, 273  
 Resonance suppression, 297  
   Activate the resonance suppression function, 298

- Manual tuning with resonance suppression (p29021=0), 299
- One-button auto tuning with resonance suppression (p29023.1=1), 298
- Real-time auto tuning with resonance suppression (p29024.6=1), 299
- Response time, 279
- Risk analysis, 271
- Risk reduction, 272

## S

- Safe Torque Off
  - functional features, 280
  - Response time, 282
  - Selecting/deselecting STO, 282
- Safety Integrated function, 276
- Safety of machinery in Europe, 265
- Save parameters in the servo drive, 175
- Search a parameter in "P ALL" menu, 172
- Selection of control mode
  - Control mode change for a compound control mode, 182
  - Control modes, 181
  - Selection of a basic control mode, 181
- Servo ON signal, 187
  - Relevant parameter settings, 187
- Set parameter set to default, 176
- Set zero position, 180
- Speed control mode
  - Direction and stop, 228
  - External speed setpoint, 226
  - Offset adjustment, 227
  - Parameter settings for fixed speed setpoint, 228
  - Ramp-function generator, 230
  - Speed setpoint, 226
  - Zero speed clamp, 229
- Speed limit, 199
  - Overall speed limit, 199
- Standards for implementing safety-related controllers, 267
- Stopping method at servo OFF, 191
  - Coast-down (OFF2), 191
  - Quick stop (OFF3), 191
  - Ramp-down (OFF1), 191
- System connection, 92

## T

- Technical data
  - Cables, 69

- Torque control mode
  - 300% overload capacity, 232
  - Direction and stop, 234
  - External analog torque setpoint, 233
  - External speed limit, 200
  - Internal speed limit, 200
  - Offset adjustment, 233
  - Torque control with fixed setpoint, 234
  - Torque setpoint, 232
- Torque limit, 200
  - External torque limit, 202
  - Internal torque limit, 201
  - Overall torque limit, 201
  - Torque limit reached (TLR), 202
- Transmitting sequence for the absolute position data, 262
- Tuning
  - Configuration of dynamic factor, 289, ?293
  - Manual tuning, 296
  - Real-time auto tuning, 292
  - Servo gains, 285
  - Tuning methods, 286
  - Tuning with SINAMICS V-ASSISTANT, 287

## U

- Update firmware, 178
- Usage of the shielding plate, 96
- USS
  - Telegram format, 235

## W

- Wiring and connecting
  - Adjusting cable orientations, 97

Siemens AG  
Digital Factory  
Motion Control  
Postfach 31 80  
91050 ERLANGEN  
Germany

Scan the QR code for  
product information

